



减速机样本

Complete gearbox catalog

高强度、高精度。
良好的合作伙伴关系。

我们始终致力于能够以有限的零件系列组合出近乎无穷多的减速机类型，并希望这一过程能够足够简便。

**Impress with power and precision.
Inspire with partnership.**

“We are fascinated by the way in which a modest number of parts can be used to build a seemingly infinite number of gearbox variants, all the while making it appear like it's quite simple.



Bernd Neugart
执行董事
Managing Partner

Matthias Herr
执行董事
Managing Partner

这可以通过我们对应用需求的理解、发挥减速机模块的智能性并借助个性化研发在短期内制定完美解决方案来实现。

我们的减速机不断完善。
坚实可靠！始终如一！信守承诺！

We achieve this because we understand the application, exploit the intelligence of our modular gearbox system and develop custom solutions within just a short time.

Our gearboxes deliver the power you need:
Reliably. Lifelong. And that's a promise.”

超强动力，高精度以及良好的合作伙伴关系是本公司90多年来始终贯彻执行的经营理念。

我们提供的产品系列包括许多创新的成熟技术和可信赖的减速机解决方案。

目前，我们针对经济型与精密型应用为您提供19个不同的减速机系列，另外针对特定应用领域提供两个高精度减速机系列。

作为您技术上的合作伙伴，我们也会提供定制的解决方案；专业的客户定制减速机。

如果您对我们的产品和服务有任何的问题，请及时与我们联系，我们将竭诚为您服务。

Power, precision and partnership – these values characterize our business philosophy and our work, and have for over 90 years.

Our offered product range includes numerous innovative, technologically mature, and highly reliable gearbox solutions. We now offer 19 different gearbox series for the economy and precision sectors, as well as two additional planetary gearbox series for specific application areas.

As a technology partner, we also provide customized solutions; specialized, custom designed gearboxes.

Please contact us with any questions about our products or services – we appreciate every opportunity to assist and meet your automation, precise motion and power transmission requirements.

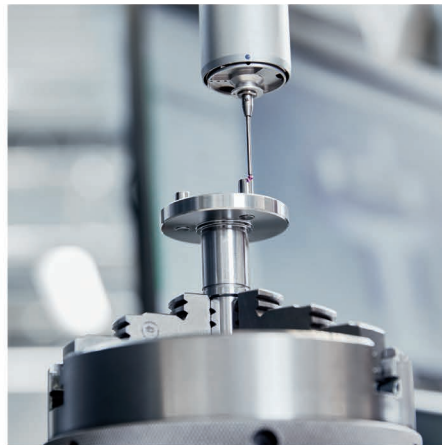

编者说明		1
Editorial		
用户定制减速机方案		4
Custom made gearboxes		
高品质		5
Quality		
服务·工具与培训		6
Tools and trainings		
对于决策者		8
For decision-makers		
行业解决方案		10
Industry solutions		
快速预览		12
Quick overview		
我们减速机的特点		15
Our gearbox features		
功率等级		16
Performance classes		
经济型减速机		
Economy Line	PLE	18
	PLQE	24
	PLPE	30
	PLHE	36
	PLFE	42
	PFHE	48
	WPLE	54
	WPLQE	60
	WPLPE	66
	WPLHE	72
	WPLFE	78
精密型减速机		
Precision Line	PSBN	84
	PSN	90
	PLN	96
	PSFN	102
	PLFN	108
	WPLN	114
	WPSFN	120
	WGN	126
装有小齿轮的高精度减速机		132
Planetary gearbox with mounted pinion	PK1	134
	PM1	136
	PM2	138
针对特定应用的减速机		
Application-specific gearboxes	NGV	140
	H LAE	148
选项: 输出法兰规格		156
Option: Output flange design		
选项: 输入系统规格		160
Option: Input design		
产品代码		162
Product Code		
技术背景		166
Technical background		
联系		168
Contact		
技术特性说明		173
Explanation of technical features		



**创新并且独特：
定制减速机**

坚固的结构设计及高性能、特殊的结构需求。食品级的认证和独特的设计：本公司可以满足客户在机械领域中的各种复杂要求。

高素质的技术工程师设计减速机系统并解决减速机各种问题。服务、成本和质量恰到好处。

创新优势：本公司将长期的专业经验以及不断的研发成果运用到客户解决办法中。

在个性化驱动解决方案的早期研发阶段，与客户的紧密合作对我们来说非常重要。我们将围绕您的特种减速机提供现场咨询和最佳服务。

**Innovative and individual:
Our custom made gearboxes.**

Compact form and high performance, special construction requirements, food grade certification or individual design: We fulfill even your most complex requirements – in all sectors of machine building.

The qualified specialists of our engineering department design gearbox solutions and systems. According to your performance, price and quality needs.

Your benefit from innovation: We utilize our experience and at the same time take advantage of new developments, integrating them into our customer solutions.

Close collaboration with our customers is important to us even in the earliest development phases of individual drive solutions. We believe in providing on-site advice and optimal service in relation to every aspect of your custom made gearbox.





高质量的产品。

顾客满意是本公司的终极目标，产品质量和服务是我们的首要任务。
本公司的质量-环保理念保证并保持了我们在国际市场上不断地取得巨大成功。

本公司在产品质量、技术支持和服务上的高标准要求得到了国际认可：在全世界所有重要的工业国家中我们拥有超过70家代理和分支机构。

本公司只在德国进行产品制造。在美国和中国的组装厂可以满足不同地区的需求并保证供货时间和货物调度的灵活性。



Power at a high level: Our quality.

Your satisfaction is our measuring stick – that's why the quality of our products and services is always our top priority. With our quality and environmental policies we secure and expand our economic success throughout international markets.

Our high standard in product quality, support and service is appreciated internationally: With over 70 representatives and branches, we are represented in all major industrial nations.

We manufacture our products exclusively in Germany. In the USA and China, our assembly factories serve regional markets, guaranteeing a high level of flexibility for adaptations as well as the shortest delivery times.





**性能强劲，操作直观：
Neugart 计算程序 – NCP**

使用 Neugart 计算程序 (NCP 4.2)，您可简单几步实现最佳的电机与减速机组合。这样一来，您的应用将变得节省成本和节能高效。在后台会有一款复杂的软件对您整个传动系统的所有参数进行计算。这款工具的操作很简单：NCP 的用户界面经过明确的分区，结构简洁，操作直观。

通过 NCP，您可查询到市场上几乎所有常见的电机和各种应用，如齿轮齿条、滚珠丝杆、皮带、输送带、转盘、曲轴和复卷机构每个阶段都有动态数据和负载的图示。您便可实时关注所使用的组件是否合适。

优点概要：

- 尺寸结构一目了然 – 一眼便可获知输入值和输出值
- 免费供 Neugart 客户或感兴趣者使用
- 离线模式 – 离线也能进行设计
- 包括 19,000 余种电机的庞大电机数据库
- 经过对所有输入数值进行可靠性测试，能够确保安全
- 所有计算步骤都能使用全面的技术文档
- 提供多种语言版本 – 输出时有七种语言可选
- 可直接在线访问所选产品的数据页和 CAD 文件

Neugart 公司将定期提供 NCP 培训
请联系：training@neugart.com

**Powerful and intuitive interface:
Neugart Calculation Program – NCP**

The Neugart Calculation Program (NCP 4.2) lets you assemble the optimal motor and gearbox combination with just a few clicks. Your application therefore becomes cost and energy efficient. In the background, a complex software routine calculates all parameters for your whole drive train. Despite this complex process, the tool is easy to use: The NCP user interface presents a clear intuitive structure.

NCP gives you access to virtually all of the conventional motors on the market and a large number of applications like pinions, spindles, belts, conveyors, rotary tables, slider cranks, and winders. Dynamics and load data are depicted as graphs in each stage. You can then see in real time whether the components you have selected are suitable or not.

Your benefits at a glance:

- Transparent dimensioning – input and output values at a glance
- Free of charge for you (as a Neugart customer or prospective)
- Offline mode – design without internet access
- Extensive database containing over 19,000 motors
- Reliability based on plausibility checks of all entered values
- Extensive technical documentation for all calculating steps
- Multilingual support – seven different languages to choose from
- Online access to dimension sheets and CAD files for the selected products

Neugart offers NCP training courses at regular intervals.
Please contact us at training@neugart.com

最新在线服务，新的选择： Tec Data Finder – TDF

仅需几步操作，Tec Data Finder (TDF) 便可为您生成减速机的所有相关信息。其中包括呈现在尺寸图中的特定技术和几何数据，以及所有常见格式的 CAD 模型。

同时，减速机的几何形状可直接在特定的电机上进行调整和调试。这需要借助全面的电机数据库或者输入对应的连接尺寸。除此之外，无需预选特定的电机便可从尺寸图和 CAD 数据库中直接下载减速机数据。

New online services, new options: Tec Data Finder – TDF

With just a few clicks, the Tec Data Finder (TDF) generates all of the information relevant to your gearbox. This includes the specific technical and geometrical data in the form of a dimension sheet as well as the CAD models in all of the usual formats.

At the same time, the gearbox geometry can be adapted and tuned directly to your specific motor. This is based on a comprehensive motor database or on manual entries of individual connection measurements. In addition, the gearbox data can also be downloaded directly from the dimension sheet and CAD database without the advance selection of a specific motor.

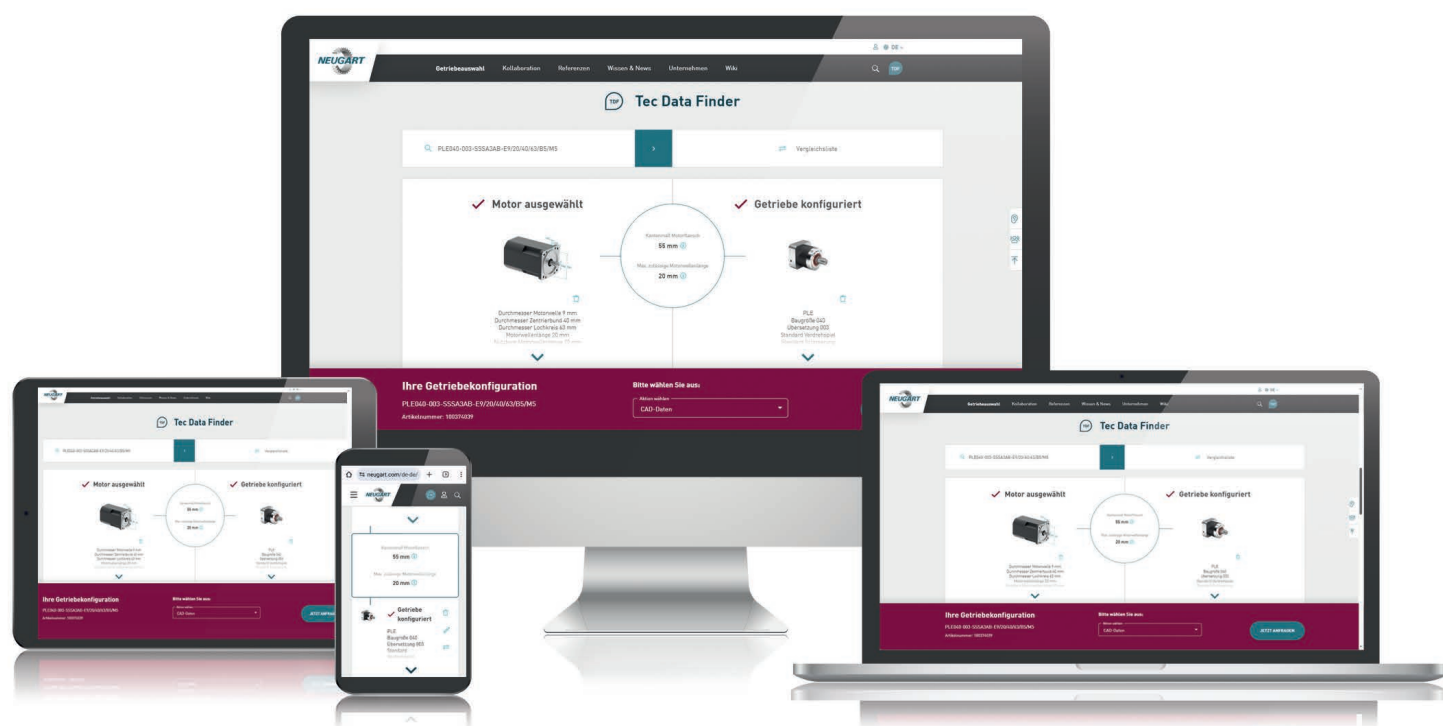

优点概要：

- 免费的在线工具
- 全面的电机数据库（超过 20,000 种电机）
- 电机-减速机法兰-几何形状的可信度测试
- 用户账号—访问更快速
- 购物车—快速的报价查询和 CAD 数据
- 配置启动—从电机或减速机开始
- 对比列表（多达5台减速机）
- 所有信息均有七种不同语言可选

Your benefits at a glance:

- Free online tool
- Comprehensive motor database (over 20,000 motors)
- Plausibility check on motor and gearbox flange geometries
- User account – for even faster access
- Request cart – for fast quote requests and CAD data
- Configuration start – begin with motor or gearbox
- Comparison list (up to 5 gearboxes)
- Information can be output in seven different languages

如欲了解有关 NCP和TDF工具的信息，请访问：
www.neugart.com

The NCP and TDF tools can be found on our website:
www.neugart.com



**注重细节，打造完美：
公司产品和我们的服务。**

公司提供各种服务项目-通过Neugart官网NCP和TDF工具，您可以进行尺寸图和产品搜索，为您提供标准的减速机选型参数。

公司在各个国家都设有分公司。公司的信息网络以及所使用的经营软件不但可以保证各个分公司可以顺利地进行通讯往来，并提供最佳的合作经营流程。

性能强，效率高且技术创新：我公司保证在减速机技术方面为您提供先进的解决方案，以及质量高，经济性的产品。



**Perfection in every detail:
Our products and our service.**

We support you with a wide range of services – from NCP, our free calculation tool, to the Neugart dimension sheet and product finders to our integrated, certified claims management.

We are represented in all major markets with local companies. Our internal information network and the business software we use ensure smooth internal communication and optimally coordinated business processes.

Powerful, efficient and innovative: We create forward-looking solutions in gearbox technology – high quality at reasonable prices.

另一项决策：
Neugart – 最佳选择.

几十年来，Neugart始终利用高科技和创新技术，持续研发以及高精密的制造技术获得了全世界客户的信赖。

我公司在精密加工减速机，特殊减速机制造以及按照客户要求生产齿轮部件方面积累了丰富的经验和技術，产品在国内和国际市场上供不应求。

凭借高效率-德国制造：您可以在公司系列产品中找到您需要的产品。

当然，公司还有很多的优点值得您选择Neugart产品。

Decidedly different:
Neugart – for good reason.

Neugart distinguishes itself with advanced, innovative technology, with high-precision production technology and has been doing so for decades. Worldwide, renowned customers put their trust in our vast experience.

Our precise planetary gearboxes and our experience in the construction of custom made gearboxes are highly sought after in national and international markets.

Put your trust in the highest level of performance – Made in Germany: In our well-balanced portfolio you will find the right product for your needs.

We can provide you with good reasons to make a decision for Neugart now.



我们是您在行星减速机领域的专家伙伴

我们是您在行星减速机领域的专家伙伴。半个世纪以来，Neugart 一直是行星减速机领域中可靠、强大且创新不断的研发团队和制造商。无论客户的需求多么复杂，我们的产品都能胜任。所以，我们逐渐成为了名副其实的驱动技术专家。我们的行业实力达到了客户在需要寻求创新解决方案时总会前来向我们咨询的程度。

直至今日，我们的产品项目实现了战略扩展和延伸，如今我们已经能够为所有应用情况提供解决方案。作为一家所有者领导型家族企业，保持可靠的形象和站在客户的角度行事对我们而言至关重要。

因此，我们始终致力于为每一个新项目设计出实际可行的解决方案。无论最终面临何种应用情况，我们都能够在许多领域如鱼得水，在需要的时间地点带去我们的专业知识和技能诀窍。其中包括：机械和基础建设的很多领域、自动化/机器人这类专业细分市场、食品和包装行业、药品技术和医药等敏感领域以及工具或印刷机制造行业。下面是我们专业能力的概况。如果您有任何问题，请随时联系我们。

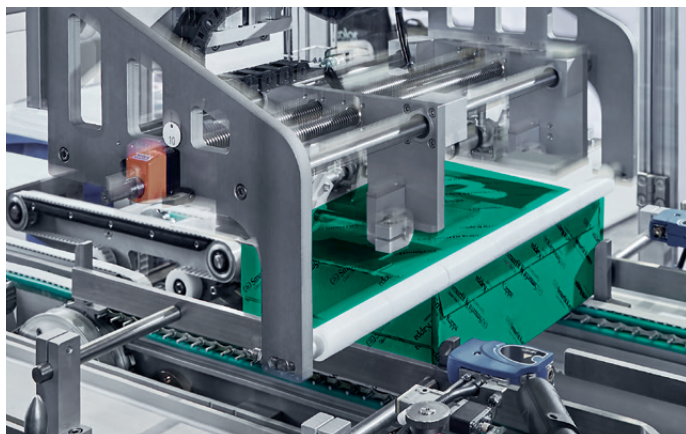
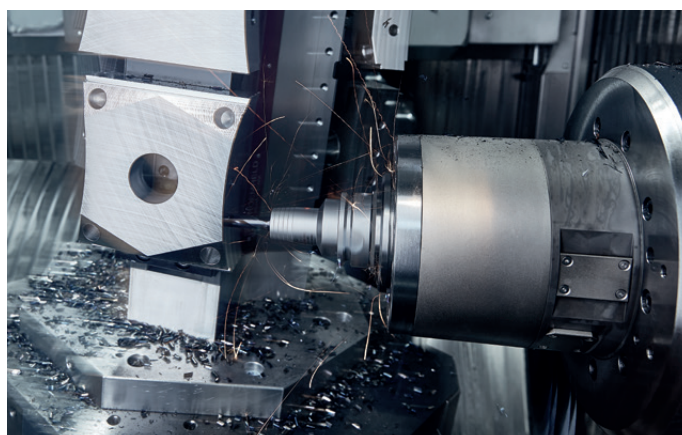

We are your specialist in planetary gearboxes.

As a reliable, trusted and innovative planetary gearbox manufacturer, Neugart has been supporting all industrial sectors for over half a century. Our products get the job done, regardless of how complex our customers' needs may be. Over the years, we have become the foremost leaders in drive technology specialization. Our vast industry knowledge allows us to support customers with their most challenging projects and to offer the latest technologies and solutions.

Our constantly expanding product inventory provides effective solutions for virtually every application of gearbox technology.

Our customers' challenges and concerns are always at the forefront of our thoughts. Listening to and reflecting upon problems helps us to expand our knowledge, in order to achieve the highest standard in design and innovation. Our mechanical and industrial expertise includes everything from automation and robotics to food and packaging to medical and pharmaceutical.

Neugart 减速机品质卓越。

通过优化产品技术和服务，为众多行业的发展提供了绝佳的机遇。欢迎使用我们的产品，相信您将受益匪浅！

Neugart gearboxes are world-class products.

Unique possibilities are available for countless industries as we continuously optimize all technologies and services related to our products. We invite you to benefit from our competitive advantages.

自动化/机器人

- 经济型减速机解决方案
- 在驱动领域积累了丰富的经验



Automation and robotics

- Cost-effective gearbox solutions
- Smart software for all product aspects

包装设备

- 减速机灵活耐用
- 经济型减速机解决方案



Packaging machines

- Dynamic and hardwearing gearboxes
- Cost-effective gearbox solutions

机床

- 丰富的应用经验
- 减速机运行可靠且使用寿命极长



Machine tools

- Extensive application experience
- Reliable and long-lasting gearboxes

食品行业

- 经过认证的卫生设计
- 全面的应用知识



Food and beverage industry

- Certified products
- Worldwide, comprehensive application knowledge

药品技术和药剂行业

- 在驱动领域积累了丰富的经验
- 经过认证的卫生设计



Medical engineering and pharmaceuticals

- Smart software for all product aspects
- Certified products

印刷行业

- 丰富的应用经验
- 最佳的印刷质量



Printing industry

- Extensive application experience
- Higher quality end product

农产品行业

- 减速机运行可靠且使用寿命极长
- 适用于恶劣环境



Agricultural machinery

- Reliable and long-lasting gearboxes
- Suitable for use in harsh conditions

Neugart完整的产品系列可以用于任何传动情况。凭借各类精密减速机，如今我们已与40多个行业成功开展了合作。

Neugart's fully developed product portfolio can handle virtually all applications with controlled motion. We are already precision gearbox partners in over 40 industries.

经济型同轴减速机

Economy Line coaxial gearboxes



PLE

页 Page **18**



PLQE

页 Page **24**



PLPE

页 Page **30**



PLHE

页 Page **36**

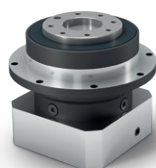

PLFE

页 Page **42**

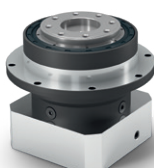

PFHE

页 Page **48**

经济型直角减速机

Economy Line right angle gearboxes



WPLE

页 Page **54**



WPLQE

页 Page **60**



WPLPE

页 Page **66**



WPLHE

页 Page **72**



WPLFE

页 Page **78**

精密型同轴减速机

Precision Line coaxial gearboxes



PSBN

页
Page **84**



PSN

页
Page **90**



PLN

页
Page **96**

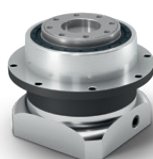

PSFN

页
Page **102**

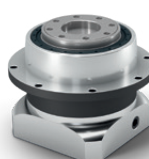

PLFN

页
Page **108**

精密型直角减速机

Precision Line right angle gearboxes



WPLN

页
Page **114**



WPSFN

页
Page **120**



WGN

页
Page **126**

装有小齿轮的高精度减速机

Planetary gearboxes with mounted pinion



PK1

页
Page **132**



PM1

页
Page **132**



PM2

页
Page **132**

针对特定应用的减速机

Application-specific gearboxes



NGV

页
Page **140**



HLAE

页
Page **148**

高效率

高精度行星减速机的工作效率高，最高为98%。传递的扭矩分配在几个齿轮上，这样每个啮合齿的摩擦就减少了。

High efficiency

Planetary gearboxes have an excellent efficiency of up to 98%. The torque being transmitted is distributed over several gearing elements, so that the friction per engaged tooth is reduced.

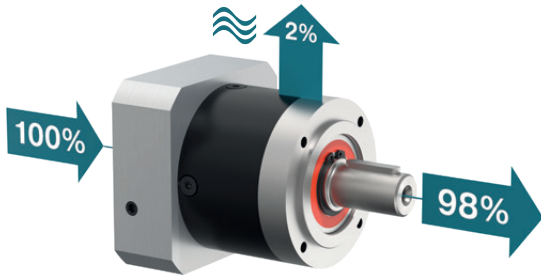

对驱动法兰进行单独调整，使其与电机适配。

在Neugart Tec Data Finder (TDF)中，只需点击几下，就可以找到各种不同的电机型号，现有20.000个不同的电机。

Individual adaptation of the drive flange to the motor

From a wide range of different motor adapters, the right adapter for up to 20,000 different motors can be found with just a few clicks in the Neugart Tec Data Finder (TDF).

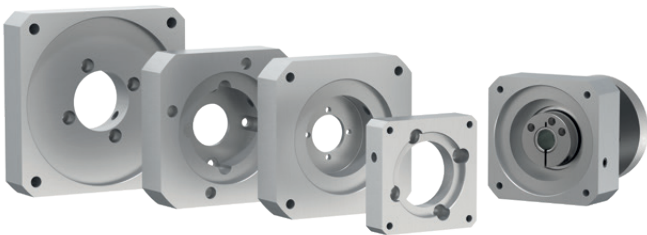

经过优化的转动惯量锁紧系统

我们减速机的锁紧系统经过重量优化变得更轻，由此提高了整个动力总成的动态性能。

Clamping systems with optimized mass moment of inertia

The clamping systems of our gearboxes are optimized for low weight, which can increase the dynamics of the entire drive train.

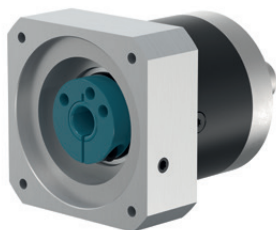

可以安装在任何位置

凭借优化的润滑设计，我们的减速机可以在任何位置上运行，而且不会降低性能。

Can be mounted in all spatial orientations

Thanks to the optimized lubrication concept, our gearboxes can be operated in any position without any loss of performance.

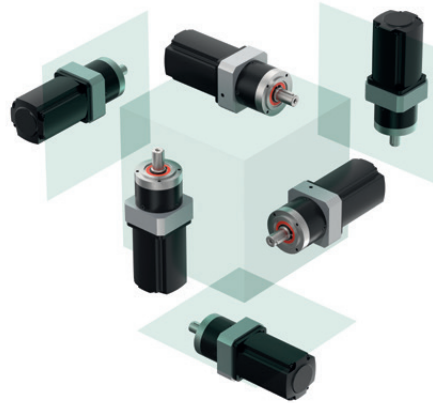

整个使用寿命过程中仅需一次润滑，无需维护

使用专门根据高精度减速机优化过的高质量润滑剂以后，在正常的应用条件下，Neugart 减速机在整个使用寿命期间无需维护。

Lifetime lubrication for maintenance-free operation

Use of high-quality lubricants, optimized specifically for the requirements in planetary gearboxes, makes Neugart gearboxes maintenance-free over their service life under normal operating conditions.

20.000 h
30.000 h

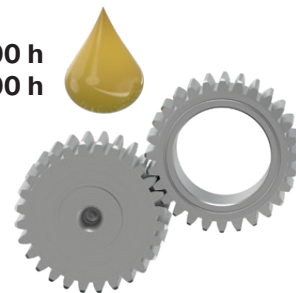

产品概览

在此概览中您可以找到产品的重要特性。

经济型	额定输出扭矩	回程间隙	轴承最大承载能力	防护等级	运行噪音	输入转速	抗扭刚性	传动比多样性
	Nominal output torque	Backlash	Bearing load	Protection class	Running noise	Input speeds	Torsional stiffness	Wide range of ratios
PLE		—	—	—	—	—	—	—
PLQE		—	—	—	—	—	—	—
PLPE		—	—	—	—	—	—	—
PLHE		—	—	—	—	—	—	—
PLFE		—	—	—	—	—	—	—
PFHE		—	—	—	—	—	—	—
WPLE		—	—	—	—	—	—	—
WPLQE		—	—	—	—	—	—	—
WPLPE		—	—	—	—	—	—	—
WPLHE		—	—	—	—	—	—	—
WPLFE		—	—	—	—	—	—	—

— 标准

— — — — 优秀

— Standard

— — — — Excellent

Our program at a glance.

In this overview you will find a direct comparison of the key features of our products.

精密型	额定输出扭矩	回程间隙	轴承最大承载能力	防护等级	运行噪音	输入转速	抗扭刚性	传动比多样性
	Nominal output torque	Backlash	Bearing load	Protection class	Running noise	Input speeds	Torsional stiffness	Wide range of ratios
PSBN	标准	标准	标准	标准	标准	标准	标准	标准
PSN	标准	标准	标准	标准	标准	标准	标准	标准
PLN	标准	标准	标准	标准	标准	标准	标准	标准
PSFN	标准	标准	标准	标准	标准	标准	标准	标准
PLFN	标准	标准	标准	标准	标准	标准	标准	标准
WPLN	标准	标准	标准	标准	标准	标准	标准	标准
WPSFN	标准	标准	标准	标准	标准	标准	标准	标准
WGN	标准	标准	标准	标准	标准	标准	标准	标准

针对特定应用的减速机	额定输出扭矩	回程间隙	轴承最大承载能力	防护等级	运行噪音	输入转速	抗扭刚性	传动比多样性
Application specific gearboxes	Nominal output torque	Backlash	Bearing load	Protection class	Running noise	Input speeds	Torsional stiffness	Wide range of ratios
HLAE	标准	标准	标准	标准	标准	标准	标准	标准
NGV	标准	标准	标准	标准	标准	标准	标准	标准

标准
 优秀
 Standard
 Excellent

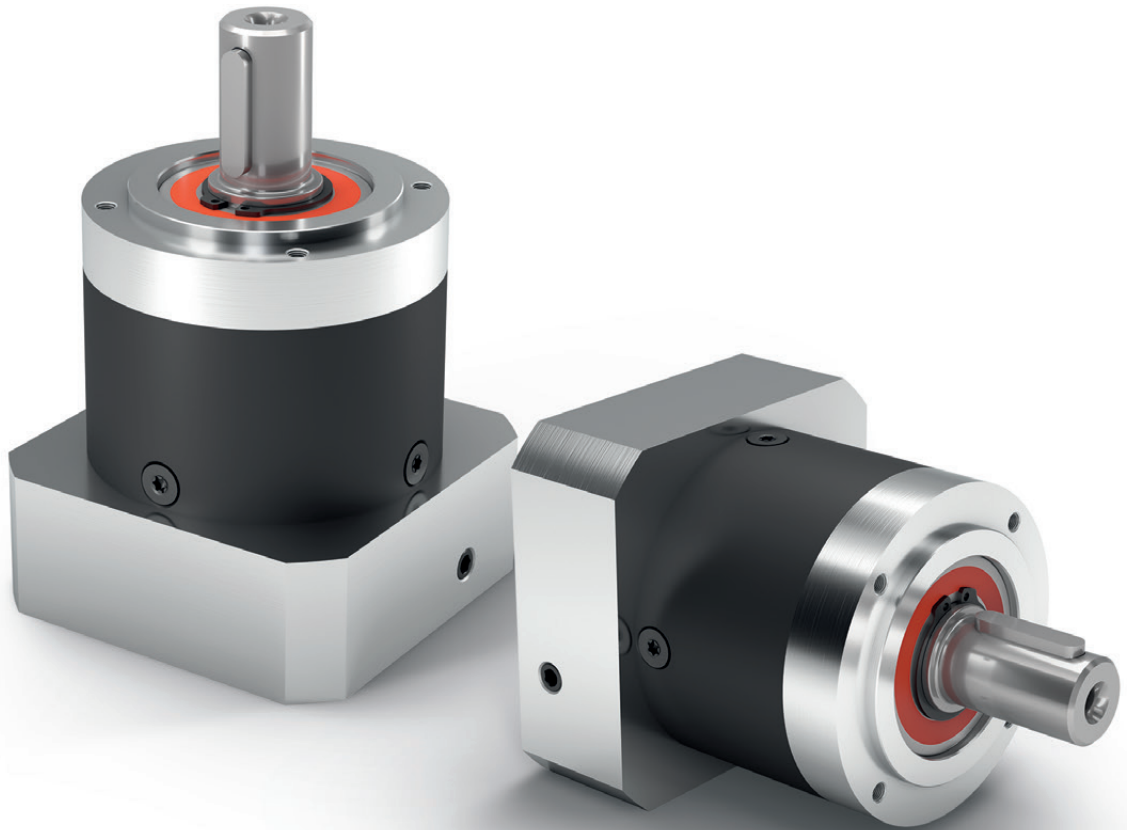

PLE

其优势在于：此款行星减速机即使在最高转速时也能达到最高效率

PLE 是我们的性价比奇迹。它的重量很轻，性能强大，轴承设计降低了振动，并且润滑效果得到了优化，因此适合高强度的生产周期。它是真正的动力单元，价格公道且富有吸引力。

Unparalleled: This planetary gearbox maintains its maximum efficiency even at the highest speeds

The **PLE** is our price/performance wonder. It is particularly lightweight, extremely powerful and yet still suitable for demanding production cycles thanks to its low-friction bearing concept and optimized lubrication. A real powerhouse at an attractive and fair price.

额定扭矩
Nominal output torque **5 - 800 Nm**

径向力
Radial force **200 - 5000 N**

轴向力
Axial force **200 - 7000 N**

回程间隙
Torsional backlash **6 - 22 arcmin**

防护等级
Protection class **IP54**

结构尺寸
Frame sizes

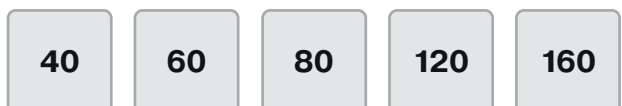

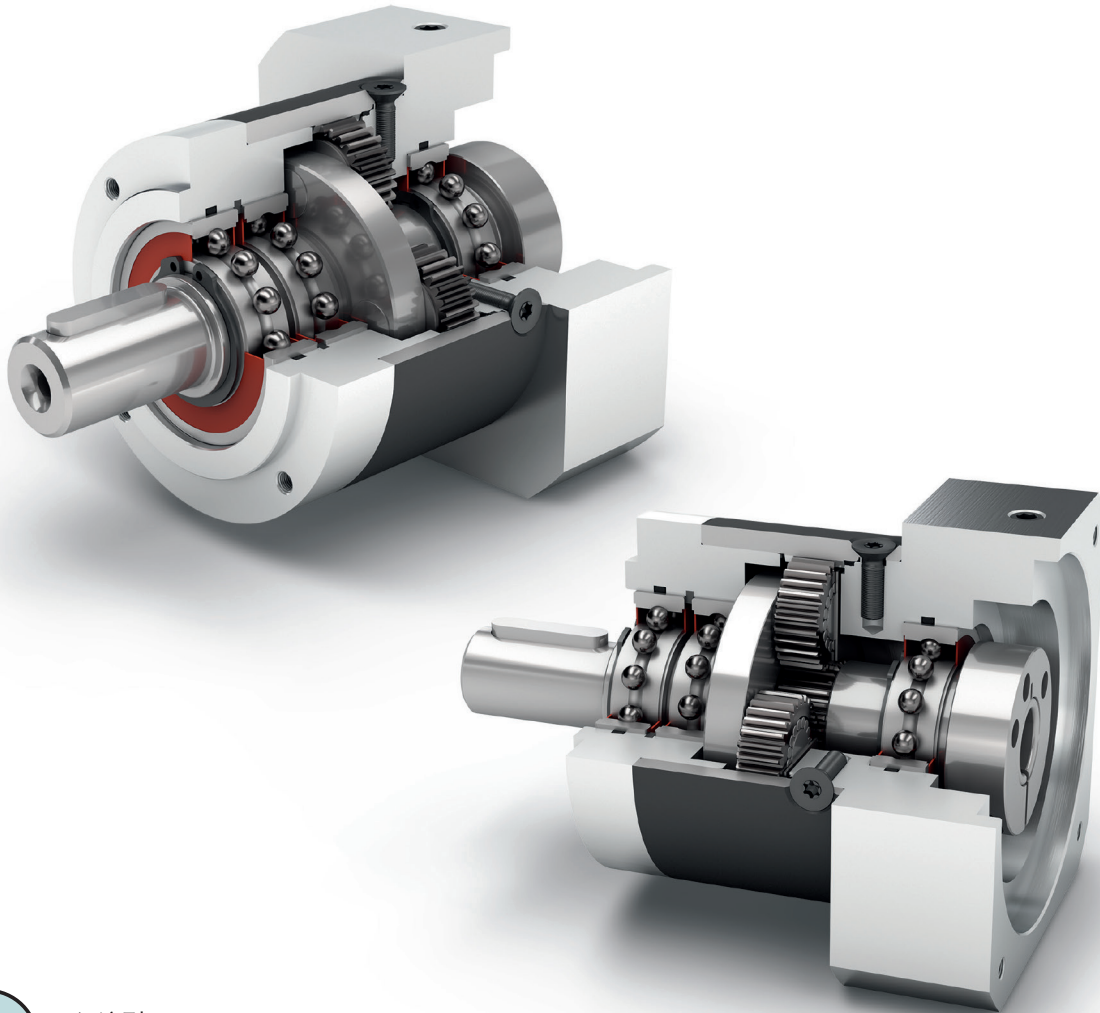

经济型
Economy Line

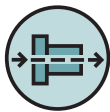

同轴减速机
Coaxial gearbox



直齿
Spur gear



低摩擦深沟球轴承
Low-friction deep groove ball bearings



行星齿轮架
Planet carrier in disc design



旋转方向 同方向
Equidirectional rotation

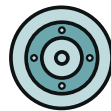

圆形输出法兰
Round type output flange



多样的传动比 (i=3 至 i=512)
High ratio variety i=3 up to i=512



可选: 喷漆表面
——RAL 9005 黑色
Option: Painted surface
- RAL 9005 Jet black

技术特点的详细解释, 请从第173页读起。
Detailed explanations of the technical features starting on page 173.

Code	减速机参数	Gearbox characteristics			PLE040	PLE060	PLE080	PLE120	PLE160	p ⁽¹⁾
	使用寿命 (L _{10h})	Service life (L _{10h})	t _L	h	30.000					
	满载时效率 ⁽²⁾	Efficiency at full load ⁽²⁾	η	%	98					1
					97					2
					92					3
	最低工作温度	Min. operating temperature	T _{min}	°C	-25					
	最高工作温度	Max. operating temperature	T _{max}		90					
	防护等级	Protection class			IP54					
S	标准润滑	Standard lubrication			润滑脂(终生润滑) / Grease (lifetime lubrication)					
F	食品级润滑	Food grade lubrication			润滑脂(终生润滑) / Grease (lifetime lubrication)					
L	低温润滑 ⁽³⁾	Low temperature lubrication ⁽³⁾			润滑脂(终生润滑) / Grease (lifetime lubrication)					
	安装位置	Installation position			任意 / Any					
S	标准回程间隙	Standard backlash	j _t	arcmin	< 15	< 10	< 7	< 7	< 6	1
					< 19	< 12	< 9	< 9	< 9	2
					< 22	< 15	< 11	< 11	-	3
	抗扭刚度 ⁽²⁾	Torsional stiffness ⁽²⁾	c _g	Nm / arcmin	0,7 - 1,0	2,1 - 2,8	7,2 - 10,0	15,5 - 21,0	57,5 - 69,0	1
					0,8 - 1,0	2,3 - 2,8	7,9 - 10,4	17,5 - 22,0	61,0 - 75,0	2
					0,8 - 1,0	2,3 - 2,8	7,9 - 10,5	17,5 - 22,0	-	3
	减速机重量 ⁽²⁾	Gearbox weight ⁽²⁾	m _G	kg	0,3 - 0,4	0,9	2,1 - 2,2	5,6 - 5,9	17,3 - 17,5	1
					0,4	1,0 - 1,1	2,6 - 2,7	7,3 - 7,7	23,2 - 23,5	2
					0,5	1,2 - 1,3	3,0 - 3,2	9,1 - 9,5	-	3
S	标准的箱体表面	Standard surface			箱体: 钢 - 热处理后氧化 (黑色) Housing: Steel - heat-treated and post-oxidized (black)					
B	喷漆表面	Painted surface			RAL 9005 黑色 RAL 9005 Jet black					
	运行噪音 ⁽⁴⁾	Running noise ⁽⁴⁾	Q _g	dB(A)	58	58	60	65	70	
	基于减速机输入法兰的最大弯矩 ⁽⁵⁾	Max. bending moment based on the gearbox input flange ⁽⁵⁾	M _b	Nm	4,5	12	16	40	140	

输出轴载荷	Output shaft loads			PLE040	PLE060	PLE080	PLE120	PLE160	p ⁽¹⁾
20.000 h 径向力 ⁽⁶⁾⁽⁷⁾	Radial force for 20,000 h ⁽⁶⁾⁽⁷⁾	F _{r20.000h}	N	200	400	750	1750	5000	
20.000 h 轴向力 ⁽⁶⁾⁽⁷⁾	Axial force for 20,000 h ⁽⁶⁾⁽⁷⁾	F _{a20.000h}		200	500	1000	2500	7000	
30.000 h 径向力 ⁽⁶⁾⁽⁷⁾	Radial force for 30,000 h ⁽⁶⁾⁽⁷⁾	F _{r30.000h}		160	340	650	1500	4200	
30.000 h 轴向力 ⁽⁶⁾⁽⁷⁾	Axial force for 30,000 h ⁽⁶⁾⁽⁷⁾	F _{a30.000h}		160	450	900	2100	6000	
最大径向力 ⁽⁷⁾⁽⁸⁾	Maximum radial force ⁽⁷⁾⁽⁸⁾	F _{r Stat}		200	700	1250	2000	5000	
最大轴向力 ⁽⁷⁾⁽⁸⁾	Maximum axial force ⁽⁷⁾⁽⁸⁾	F _{a Stat}		240	800	1600	3800	11000	
20.000 h 倾斜力矩 ⁽⁶⁾⁽⁸⁾	Tilting moment for 20,000 h ⁽⁶⁾⁽⁸⁾	M _{K20.000h}	Nm	6	14	31	101	474	
30.000 h 倾斜力矩 ⁽⁶⁾⁽⁸⁾	Tilting moment for 30,000 h ⁽⁶⁾⁽⁸⁾	M _{K30.000h}		4	12	27	86	398	

转动惯量	Moment of inertia			PLE040	PLE060	PLE080	PLE120	PLE160	p ⁽¹⁾
转动惯量 ⁽²⁾	Mass moment of inertia ⁽²⁾	J	kgcm ²	0,014	0,065	0,359	1,378	3,726	1
				-	-	-	-	-	
				0,027	0,128	0,654	2,361	11,999	2
				0,015	0,066	0,365	1,414	3,502	
				-	-	-	-	-	
				0,026	0,121	0,613	2,288	10,087	3
0,015	0,066	0,365	1,413	-					
-	-	-	-	-					
0,025	0,076	0,590	2,196	-					

(1) 减速机级数

(2) 传动比相关的数值可在 Tec Data Finder 中检索 - www.neugart.com

(3) T_{min} = -40°C. 理想运行温度最高为 50°C

(4) 距离减速机 1 m 时: 在输入转速为 n₁=3000 min⁻¹ 且无负荷时测得: i=5

(5) 最大电机重量* (单位: kg) = 0.2 x M_b / 电机长度 (单位: m)

* 电机重量对称分布

* 水平和固定的安装位置

(6) 数据以 n₂=100 min⁻¹ 的输出轴转速为准。

(7) 以输出轴中心为准

(8) 更改 T_{2N}, F_r, F_a 以及周期和轴承使用寿命时, 数值存在偏差 (部分较高)。利用 NCP 针对应用进行专门设计 - www.neugart.com

(1) Number of stages

(2) The ratio-dependent values can be retrieved in Tec Data Finder - www.neugart.com

(3) T_{min} = -40°C. Optimal operating temperature max. 50°C

(4) Sound pressure level from 1 m, measured on input running at n₁=3000 rpm no load; i=5

(5) Max. motor weight* in kg = 0.2 x M_b / motor length in m

* with symmetrically distributed motor weight

* with horizontal and stationary mounting

(6) These values are based on an output shaft speed of n₂=100 rpm

(7) Based on center of output shaft

(8) Other (sometimes higher) values following changes to T_{2N}, F_r, F_a, cycle, and service life of bearing. Application specific configuration with NCP - www.neugart.com

输出扭矩	Output torques			PLE040	PLE060	PLE080	PLE120	PLE160	i ⁽¹⁾	p ⁽²⁾
额定输出扭矩 ⁽³⁾⁽⁴⁾	Nominal output torque ⁽³⁾⁽⁴⁾	T _{2N}	Nm	11	28	85	115	400	3	1
				15	38	115	155	450	4	
				14	40	110	195	450	5	
				8,5	25	65	135	-	7	
				6	18	50	120	450	8	
				5	15	38	95	-	10	
				16,5	44	130	210	-	9	
				20	44	120	260	800	12	
				18	44	110	230	700	15	
				20	44	120	260	800	16	
				20	44	120	260	800	20	
				18	40	110	230	700	25	
				20	44	120	260	800	32	
				18	40	110	230	700	40	
				7,5	18	50	120	450	64	
				20	44	110	260	-	60	
				20	44	120	260	-	80	
				20	44	120	260	-	100	
				18	44	110	230	-	120	
				20	44	120	260	-	160	
				18	40	110	230	-	200	
				20	44	120	260	-	256	
				18	40	110	230	-	320	
				7,5	18	50	120	-	512	
最大输出扭矩 ⁽⁴⁾⁽⁵⁾	Max. output torque ⁽⁴⁾⁽⁵⁾	T _{2max}	Nm	17,5	45	136	184	640	3	1
				24	61	184	248	720	4	
				22	64	176	312	720	5	
				13,5	40	104	216	-	7	
				10	29	80	192	720	8	
				8	24	61	152	-	10	
				26	70	208	336	-	9	
				32	70	192	416	1280	12	
				29	70	176	368	1120	15	
				32	70	192	416	1280	16	
				32	70	192	416	1280	20	
				29	64	176	368	1120	25	
				32	70	192	416	1280	32	
				29	64	176	368	1120	40	
				12	29	80	192	720	64	
				32	70	176	416	-	60	
				32	70	192	416	-	80	
				32	70	192	416	-	100	
				29	70	176	368	-	120	
				32	70	192	416	-	160	
				29	64	176	368	-	200	
				32	70	192	416	-	256	
				29	64	176	368	-	320	
				12	29	80	192	-	512	

⁽¹⁾ 传动比 (i=n₁/n₂)

⁽²⁾ 减速机级数

⁽³⁾ 利用 NCP 针对应用进行专门设计 - www.neugart.com

⁽⁴⁾ 平键 (代码 "A")时的数值: 针对交变载荷

⁽⁵⁾ 允许输出轴转动30.000转; 参见第 166 页

⁽¹⁾ Ratios (i=n₁/n₂)

⁽²⁾ Number of stages

⁽³⁾ Application specific configuration with NCP - www.neugart.com

⁽⁴⁾ Values for feather key (code "A"): for repeated load

⁽⁵⁾ 30,000 rotations of the output shaft permitted; see page 167

输出扭矩	Output torques			PLE040	PLE060	PLE080	PLE120	PLE160	i ⁽¹⁾	p ⁽²⁾
急停扭矩 ⁽³⁾	Emergency stop torque ⁽³⁾	T _{2Stop}	Nm	22,5	66	180	390	800	3	1
				30	88	240	520	900	4	
				36	80	220	500	900	5	
				26	80	178	340	-	7	
				27	80	190	380	900	8	
				27	80	200	480	-	10	
				33	88	260	500	-	9	
				40	88	240	520	1600	12	2
				36	88	220	500	1400	15	
				40	88	240	520	1600	16	
				40	88	240	520	1600	20	
				36	80	220	500	1400	25	
				40	88	240	520	1600	32	
				36	80	220	500	1400	40	
				27	80	190	380	900	64	3
				40	88	220	520	-	60	
				40	88	240	520	-	80	
				40	88	240	520	-	100	
				36	88	220	500	-	120	
				40	88	240	520	-	160	
				36	80	220	500	-	200	
40	88	240	520	-	256					
36	80	220	500	-	320					
27	80	190	380	-	512					

输入转速	Input speeds			PLE040	PLE060	PLE080	PLE120	PLE160	i ⁽¹⁾	p ⁽²⁾
T _{2N} 和 S1 时的平均热输入转速 ⁽⁴⁾⁽⁵⁾	Average thermal input speed at T _{2N} and S1 ⁽⁴⁾⁽⁵⁾	n _{1N}	min ⁻¹	5000	4500	4000 ⁽⁶⁾	3400 ⁽⁶⁾	1350 ⁽⁶⁾	3	1
				5000	4500	3900 ⁽⁶⁾	3500 ⁽⁶⁾	1450 ⁽⁶⁾	4	
				5000	4500	4000 ⁽⁶⁾	3500 ⁽⁶⁾	1700 ⁽⁶⁾	5	
				5000	4500	4000	3500	-	7	
				5000	4500	4000	3500	2200 ⁽⁶⁾	8	
				5000	4500	4000	3500	-	10	
				5000	4500	4000 ⁽⁶⁾	3500 ⁽⁶⁾	-	9	
				5000	4500	4000 ⁽⁶⁾	3500 ⁽⁶⁾	1600 ⁽⁶⁾	12	2
				5000	4500	4000	3500 ⁽⁶⁾	1900 ⁽⁶⁾	15	
				5000	4500	4000	3500 ⁽⁶⁾	1800 ⁽⁶⁾	16	
				5000	4500	4000	3500	2100 ⁽⁶⁾	20	
				5000	4500	4000	3500	2400 ⁽⁶⁾	25	
				5000	4500	4000	3500	2700 ⁽⁶⁾	32	
				5000	4500	4000	3500	3000 ⁽⁶⁾	40	
				5000	4500	4000	3500	3000	64	3
				5000	4500	4000	3500	-	60	
				5000	4500	4000	3500	-	80	
				5000	4500	4000	3500	-	100	
				5000	4500	4000	3500	-	120	
				5000	4500	4000	3500	-	160	
				5000	4500	4000	3500	-	200	
5000	4500	4000	3500	-	256					
5000	4500	4000	3500	-	320					
5000	4500	4000	3500	-	512					
最高机械输入转速 ⁽⁴⁾	Max. mechanical input speed ⁽⁴⁾	n _{1Limit}	min ⁻¹	18000	13000	7000	6500	6500		1
				18000	13000	7000	6500	6500		2
				18000	13000	7000	6500	-		3

(1) 传动比 (i=n₁/n₂)
 (2) 减速机级数
 (3) 允许 1000 次
 (4) 利用 NCP 针对应用设计转速 - www.neugart.com
 (5) 定义请参见第 166 页
 (6) 在 50% T_{2N} 输出和 S1 模式下的平均热输入转速

(1) Ratios (i=n₁/n₂)
 (2) Number of stages
 (3) Permitted 1000 times
 (4) Application-specific speed configurations with NCP - www.neugart.com
 (5) See page 167 for the definition
 (6) Average thermal input speed at 50% T_{2N} and S1

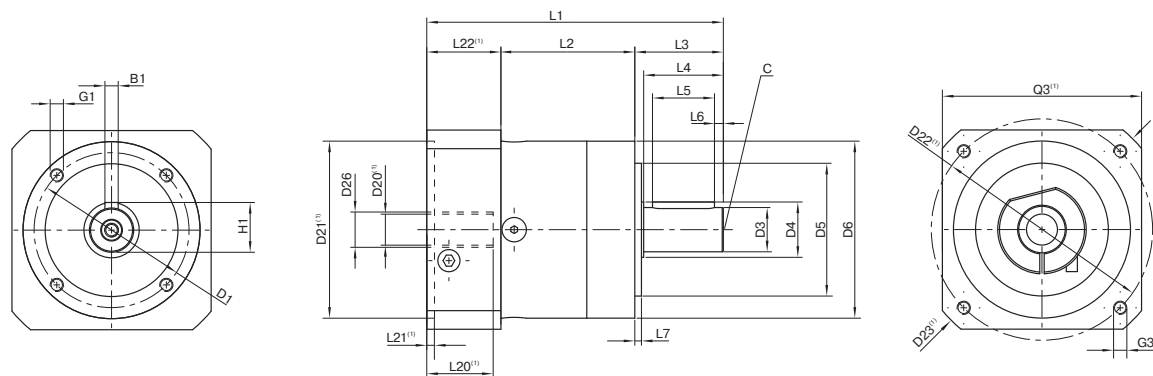

图示为带平键的 PLE060 / 1 级 / 附带平键的输出轴 / 11 mm 锁紧系统 / 适配电机法兰 - 单一法兰 / B5 电机法兰类型
 Drawing corresponds to a PLE060 / 1-stage / output shaft with feather key / 11 mm clamping system / motor adaptation – one part / B5 flange type motor

⁽¹⁾ 具体尺寸视电机/减速机法兰而定。可以在 www.neugart.com 下 Tec Data Finder 中针对每个电机适配电机特有的输入法兰几何尺寸。
⁽¹⁾ The dimensions vary with the motor/gearbox flange. The input flange dimensions can be retrieved for each specific motor in Tec Data Finder at www.neugart.com

几何尺寸 ⁽²⁾	Geometry ⁽²⁾			PLE040	PLE060	PLE080	PLE120	PLE160	p ⁽³⁾	Code
输出端安装孔节圆直径	Pitch circle diameter output	D1		34	52	70	100	145		
输出轴直径	Shaft diameter output	D3	h7	10	14	20	25	40		
输出轴轴肩直径	Shaft collar output	D4		12	17	25	35	55		
输出端定位凸台直径	Centering diameter output	D5	h7	26	40	60	80	130		
箱体直径	Housing diameter	D6		40	60	80	115	160		
安装螺纹 x 深度	Mounting thread x depth	G1	4x	M4x6	M5x8	M6x10	M10x16	M12x20		
最小总长	Min. total length	L1		88,5	106	133,5	176,5	255,5	1	
				106,5	118,5	150,5	204	305	2	
				114	131	168,5	231,5	-	3	
箱体长度	Housing length	L2		39	47	60	74	104	1	
				51,5	59,5	78	102	153,5	2	
				64,5	72	95,5	129,5	-	3	
输出轴轴长	Shaft length output	L3		26	35	40	55	87		
输出端定位凸台深度	Centering depth output	L7		2	3	3	4	5		
电机轴直径 j6/k6	Motor shaft diameter j6/k6	D20		更多信息见第 163/164 页 More information on page 163/164						
输入端锁紧系统直径	Clamping system diameter input	D26		更多信息见第 163/164 页 More information on page 163/164						
带平键的输出轴 (DIN 6885-1)	Output shaft with feather key (DIN 6885-1)			A 3x3x18	A 5x5x25	A 6x6x28	A 8x7x40	A 12x8x65		A
平键宽度 (DIN 6885-1)	Feather key width (DIN 6885-1)	B1		3	5	6	8	12		
含平键在内的轴高 (DIN 6885-1)	Shaft height including feather key (DIN 6885-1)	H1		11,2	16	22,5	28	43		
到轴肩的距离	Shaft length from shoulder	L4		23	30	36	50	80		
平键长度	Feather key length	L5		18	25	28	40	65		
到轴端的距离	Distance from shaft end	L6		2,5	2,5	4	5	8		
中心孔 (DIN 332, DR)	Center hole (DIN 332, type DR)	C		M3x9	M5x12,5	M6x16	M10x22	M16x36		
光滑输出轴	Smooth output shaft									B
到轴肩的距离	Shaft length from shoulder	L4		23	30	36	50	80		

⁽²⁾ 所有的尺寸单位为mm
⁽³⁾ 减速机级数

⁽²⁾ Dimensions in mm
⁽³⁾ Number of stages

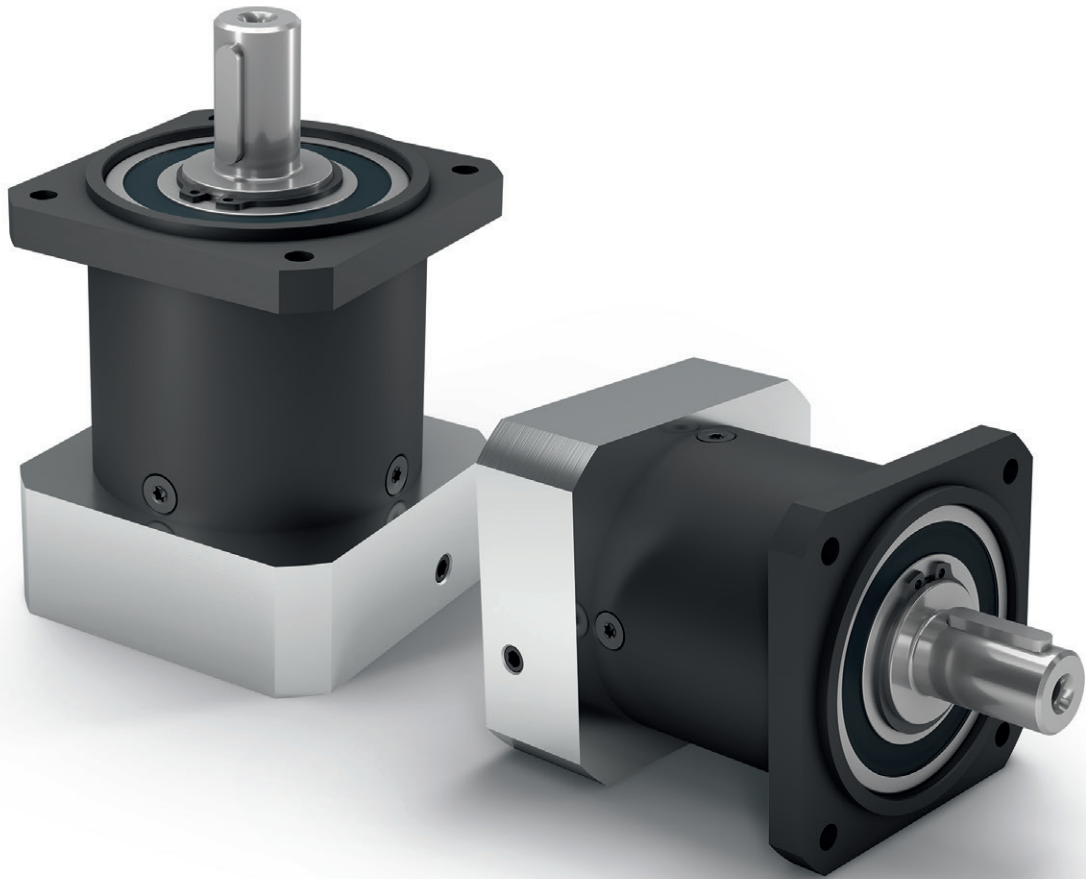

PLQE

一款安装便捷的行星减速机
发热量低
可承受较高的力

我们的 **PLQE** 结构简单且性能强大。它可以直接和您的系统连接，不需要中间法兰。输出装置上的大型深沟球轴承可以承受较高的轴向力和径向力。它凭借着良好的传动效率，即使在严苛的生产周期内也能始终可靠地运行。

The easy to install planetary gearbox
absorbs high forces
with low heat generation

Our **PLQE** is uncomplicated and powerful. It can be connected directly to your installation without the need for an intermediate flange. The larger deep groove ball bearings on the output allow higher axial and radial forces to be absorbed. Thanks to its favorable efficiency, this means that it always operates reliably even when production cycles are demanding.

额定扭矩
Nominal output torque **5 - 260 Nm**

径向力
Radial force **390 - 2950 N**

轴向力
Axial force **620 - 2500 N**

回程间隙
Torsional backlash **7 - 15 arcmin**

防护等级
Protection class **IP54**

结构尺寸
Frame sizes



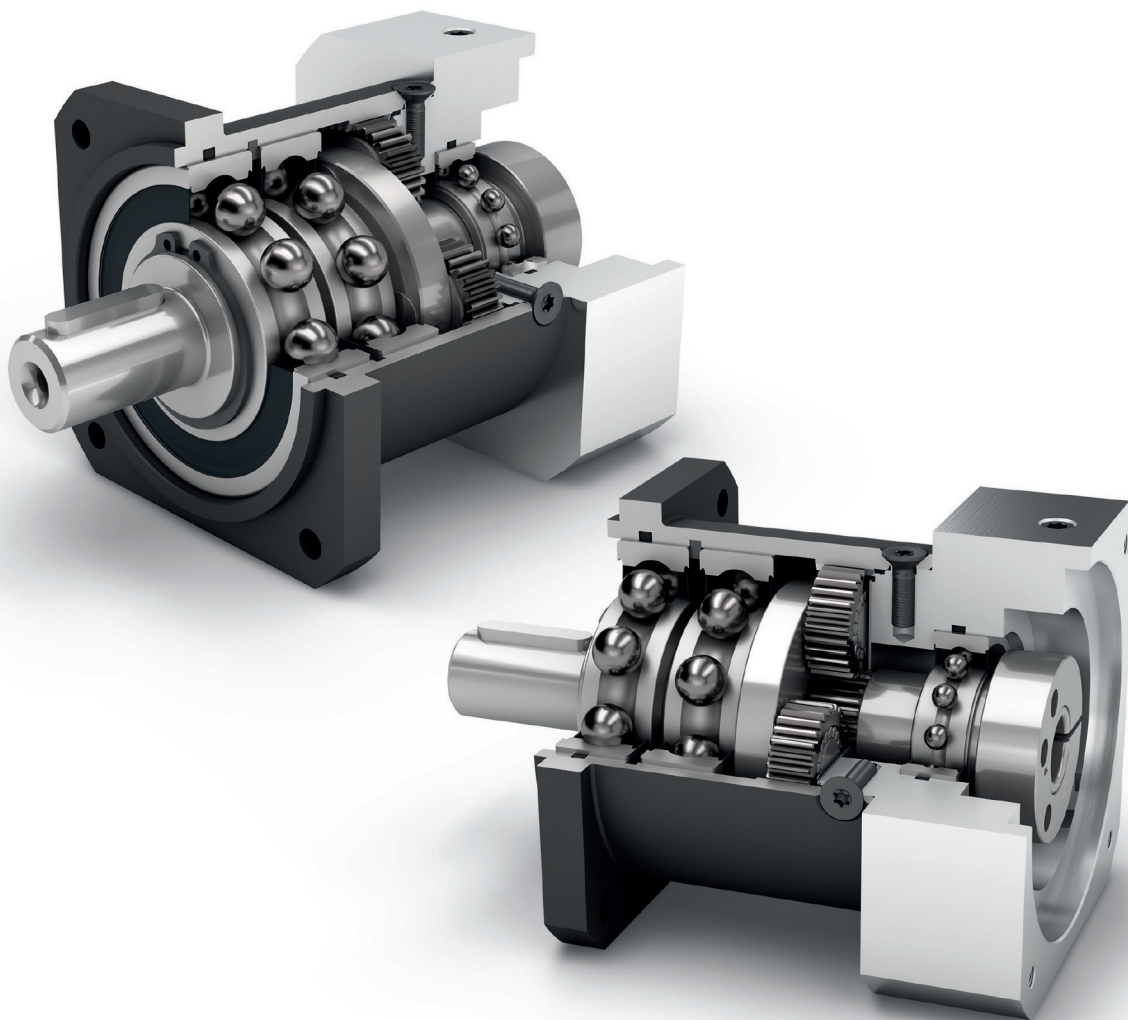

经济型
Economy Line



同轴减速机
Coaxial gearbox



直齿
Spur gear



增强深沟球轴承
Reinforced deep groove ball bearings



行星齿轮架
Planet carrier in disc design



旋转方向 同方向
Equidirectional rotation

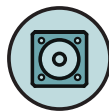

正方形输出法兰
Square type output flange



多样的传动比 (i=3 至 i=512)
High ratio variety i=3 up to i=512



可选：喷漆表面
——RAL 9005 黑色
Option: Painted surface
- RAL 9005 Jet black

技术特点的详细解释，请从第173页读起。
Detailed explanations of the technical features starting on page 173.

PLQE

Code	减速机参数	Gearbox characteristics			PLQE040	PLQE060	PLQE080	PLQE120	p ⁽¹⁾
	使用寿命 (L _{10h})	Service life (L _{10h})	t _L	h	30.000				
	满载时效率 ⁽²⁾	Efficiency at full load ⁽²⁾	η	%	98				1
					97				2
					92				3
	最低工作温度	Min. operating temperature	T _{min}	°C	-25				
	最高工作温度	Max. operating temperature	T _{max}		90				
	防护等级	Protection class			IP54				
S	标准润滑	Standard lubrication			润滑脂(终生润滑) / Grease (lifetime lubrication)				
F	食品级润滑	Food grade lubrication			润滑脂(终生润滑) / Grease (lifetime lubrication)				
L	低温润滑 ⁽³⁾	Low temperature lubrication ⁽³⁾			润滑脂(终生润滑) / Grease (lifetime lubrication)				
	安装位置	Installation position			任意 / Any				
S	标准回程间隙	Standard backlash	j _t	arcmin	< 15	< 10	< 7	< 7	1
					< 19	< 12	< 9	< 9	2
					< 22	< 15	< 11	< 11	3
	抗扭刚度 ⁽²⁾	Torsional stiffness ⁽²⁾	c _g	Nm / arcmin	1,2 - 2,2	2,8 - 4,0	8,5 - 12,6	14,0 - 18,5	1
					1,4 - 2,5	3,3 - 4,1	9,4 - 13,3	15,6 - 19,0	2
					1,5 - 2,6	3,3 - 4,1	9,4 - 13,4	15,6 - 19,0	3
	减速机重量 ⁽²⁾	Gearbox weight ⁽²⁾	m _G	kg	0,4	1,1	2,6 - 3,0	6,4 - 6,7	1
					0,5	1,3	3,4 - 3,5	8,1 - 8,5	2
					0,6	1,5	3,9 - 4,0	9,9 - 10,3	3
S	标准的箱体表面	Standard surface			箱体: 钢 - 热处理后氧化 (黑色) Housing: Steel - heat-treated and post-oxidized (black)				
B	喷漆表面	Painted surface			RAL 9005 黑色 RAL 9005 Jet black				
	运行噪音 ⁽⁴⁾	Running noise ⁽⁴⁾	Q _g	dB(A)	58	58	60	65	
	基于减速机输入法兰的最大弯矩 ⁽⁵⁾	Max. bending moment based on the gearbox input flange ⁽⁵⁾	M _b	Nm	4,5	12	16	40	

输出轴载荷	Output shaft loads			PLQE040	PLQE060	PLQE080	PLQE120	p ⁽¹⁾
20.000 h 径向力 ⁽⁶⁾⁽⁷⁾	Radial force for 20,000 h ⁽⁶⁾⁽⁷⁾	F _{r20.000h}	N	250 - 390	900	2050	2950	
20.000 h 轴向力 ⁽⁶⁾⁽⁷⁾	Axial force for 20,000 h ⁽⁶⁾⁽⁷⁾	F _{a20.000h}		620	1000	2500	2500	
30.000 h 径向力 ⁽⁶⁾⁽⁷⁾	Radial force for 30,000 h ⁽⁶⁾⁽⁷⁾	F _{r30.000h}		250 - 340	700	1700	2400	
30.000 h 轴向力 ⁽⁶⁾⁽⁷⁾	Axial force for 30,000 h ⁽⁶⁾⁽⁷⁾	F _{a30.000h}		620	800	2000	2100	
最大径向力 ⁽⁷⁾⁽⁸⁾	Maximum radial force ⁽⁷⁾⁽⁸⁾	F _{rStat}		520	1500	2500	4000	
最大轴向力 ⁽⁷⁾⁽⁸⁾	Maximum axial force ⁽⁷⁾⁽⁸⁾	F _{aStat}		620	1950	3800	3800	
20.000 h 倾斜力矩 ⁽⁶⁾⁽⁸⁾	Tilting moment for 20,000 h ⁽⁶⁾⁽⁸⁾	M _{K20.000h}	Nm	7 - 10	37	102	232	
30.000 h 倾斜力矩 ⁽⁶⁾⁽⁸⁾	Tilting moment for 30,000 h ⁽⁶⁾⁽⁸⁾	M _{K30.000h}		7 - 9	29	84	188	

转动惯量	Moment of inertia			PLQE040	PLQE060	PLQE080	PLQE120	p ⁽¹⁾
转动惯量 ⁽²⁾	Mass moment of inertia ⁽²⁾	J	kgcm ²	0,015 - 0,029	0,066 - 0,142	0,371 - 0,783	1,381 - 2,393	1
				0,015 - 0,026	0,066 - 0,123	0,366 - 0,625	1,414 - 2,292	2
				0,015 - 0,025	0,066 - 0,076	0,365 - 0,590	1,413 - 2,196	3

(1) 减速机级数
 (2) 传动比相关的数值可在 Tec Data Finder 中检索 - www.neugart.com
 (3) T_{min} = -40°C. 理想运行温度最高为 50°C
 (4) 距离减速机 1 m 时: 在输入转速为 n₁=3000 min⁻¹ 且无负荷时测得: i=5
 (5) 最大电机重量* (单位: kg) = 0.2 × M_b / 电机长度 (单位: m)
 * 电机重量对称分布
 * 水平和固定的安装位置
 (6) 数据以 n₂=100 min⁻¹ 的输出轴转速为准。
 (7) 以输出轴中心为准
 (8) 更改 T_{2N}, F_r, F_a 以及周期和轴承使用寿命时, 数值存在偏差 (部分较高)。利用 NCP 针对应用进行专门设计 - www.neugart.com

(1) Number of stages
 (2) The ratio-dependent values can be retrieved in Tec Data Finder - www.neugart.com
 (3) T_{min} = -40°C. Optimal operating temperature max. 50°C
 (4) Sound pressure level from 1 m, measured on input running at n₁=3000 rpm no load; i=5
 (5) Max. motor weight* in kg = 0.2 × M_b / motor length in m
 * with symmetrically distributed motor weight
 * with horizontal and stationary mounting
 (6) These values are based on an output shaft speed of n₂=100 rpm
 (7) Based on center of output shaft
 (8) Other (sometimes higher) values following changes to T_{2N}, F_r, F_a, cycle, and service life of bearing. Application specific configuration with NCP - www.neugart.com

输出扭矩	Output torques			PLQE040	PLQE060	PLQE080	PLQE120	i ⁽¹⁾	p ⁽²⁾
额定输出扭矩 ⁽³⁾⁽⁴⁾	Nominal output torque ⁽³⁾⁽⁴⁾	T _{2N}	Nm	11	28	85	115	3	1
				15	38	115	155	4	
				14	40	110	195	5	
				8,5	25	65	135	7	
				6	18	50	120	8	
				5	15	38	95	10	
				16,5	44	130	210	9	
				20	44	120	260	12	
				18	44	110	230	15	
				20	44	120	260	16	
				20	44	120	260	20	
				18	40	110	230	25	
				20	44	120	260	32	
				18	40	110	230	40	
				7,5	18	50	120	64	
				20	44	110	260	60	
				20	44	120	260	80	
				20	44	120	260	100	
				18	44	110	230	120	
				20	44	120	260	160	
				18	40	110	230	200	
20	44	120	260	256					
18	40	110	230	320					
7,5	18	50	120	512					
最大输出扭矩 ⁽⁴⁾⁽⁵⁾	Max. output torque ⁽⁴⁾⁽⁵⁾	T _{2max}	Nm	17,5	45	136	184	3	1
				24	61	184	248	4	
				22	64	176	312	5	
				13,5	40	104	216	7	
				10	29	80	192	8	
				8	24	61	152	10	
				26	70	208	336	9	
				32	70	192	416	12	
				29	70	176	368	15	
				32	70	192	416	16	
				32	70	192	416	20	
				29	64	176	368	25	
				32	70	192	416	32	
				29	64	176	368	40	
				12	29	80	192	64	
				32	70	176	416	60	
				32	70	192	416	80	
				32	70	192	416	100	
				29	70	176	368	120	
				32	70	192	416	160	
				29	64	176	368	200	
32	70	192	416	256					
29	64	176	368	320					
12	29	80	192	512					

PLQE

⁽¹⁾ 传动比 (i=n₁/n₂)

⁽²⁾ 减速机级数

⁽³⁾ 利用 NCP 针对应用进行专门设计 – www.neugart.com

⁽⁴⁾ 平键 (代码 "A")时的数值: 针对交变载荷

⁽⁵⁾ 允许输出轴转动30.000转; 参见第 166 页

⁽¹⁾ Ratios (i=n₁/n₂)

⁽²⁾ Number of stages

⁽³⁾ Application specific configuration with NCP – www.neugart.com

⁽⁴⁾ Values for feather key (code "A"): for repeated load

⁽⁵⁾ 30,000 rotations of the output shaft permitted; see page 167

PLQE

输出扭矩	Output torques			PLQE040	PLQE060	PLQE080	PLQE120	i ⁽¹⁾	p ⁽²⁾
急停扭矩 ⁽³⁾	Emergency stop torque ⁽³⁾	T _{2Stop}	Nm	22,5	66	180	390	3	1
				30	88	240	520	4	
				36	80	220	500	5	
				26	80	178	340	7	
				27	80	190	380	8	
				27	80	200	480	10	
				33	88	260	500	9	2
				40	88	240	520	12	
				36	88	220	500	15	
				40	88	240	520	16	
				40	88	240	520	20	
				36	80	220	500	25	
				40	88	240	520	32	
				36	80	220	500	40	
				27	80	190	380	64	
				40	88	220	520	60	
				40	88	240	520	80	
				40	88	240	520	100	
				36	88	220	500	120	
				40	88	240	520	160	
				36	80	220	500	200	
				40	88	240	520	256	
				36	80	220	500	320	
				27	80	190	380	512	

输入转速	Input speeds			PLQE040	PLQE060	PLQE080	PLQE120	i ⁽¹⁾	p ⁽²⁾	
T _{2N} 和 S1 时的平均热输入转速 ⁽⁴⁾⁽⁵⁾	Average thermal input speed at T _{2N} and S1 ⁽⁴⁾⁽⁵⁾	n _{1N}	min ⁻¹	5000	4500 ⁽⁶⁾	3400 ⁽⁶⁾	3400 ⁽⁶⁾	3	1	
				5000	4500 ⁽⁶⁾	3450 ⁽⁶⁾	3500 ⁽⁶⁾	4		
				5000	4500	4000 ⁽⁶⁾	3500 ⁽⁶⁾	5		
				5000	4500	4000	3500	7		
				5000	4500	4000	3500	8		
				5000	4500	4000	3500	10		
				5000	4500	4000 ⁽⁶⁾	3500 ⁽⁶⁾	9	2	
				5000	4500	4000 ⁽⁶⁾	3500 ⁽⁶⁾	12		
				5000	4500	4000	3500 ⁽⁶⁾	15		
				5000	4500	4000	3500 ⁽⁶⁾	16		
				5000	4500	4000	3500	20		
				5000	4500	4000	3500	25		
				5000	4500	4000	3500	32		
				5000	4500	4000	3500	40		
				5000	4500	4000	3500	64		
				5000	4500	4000	3500	60		
				5000	4500	4000	3500	80		3
				5000	4500	4000	3500	100		
				5000	4500	4000	3500	120		
				5000	4500	4000	3500	160		
				5000	4500	4000	3500	200		
				5000	4500	4000	3500	256		
				5000	4500	4000	3500	320		
				5000	4500	4000	3500	512		
最高机械输入转速 ⁽⁴⁾	Max. mechanical input speed ⁽⁴⁾	n _{1Limit}	min ⁻¹	18000	13000	7000	6500			

(1) 传动比 (i=n₁/n₂)
 (2) 减速机级数
 (3) 允许 1000 次
 (4) 利用 NCP 针对应用设计转速 – www.neugart.com
 (5) 定义请参见第 166 页
 (6) 在 50% T_{2N} 输出和 S1 模式下的平均热输入转速

(1) Ratios (i=n₁/n₂)
 (2) Number of stages
 (3) Permitted 1000 times
 (4) Application-specific speed configurations with NCP – www.neugart.com
 (5) See page 167 for the definition
 (6) Average thermal input speed at 50% T_{2N} and S1

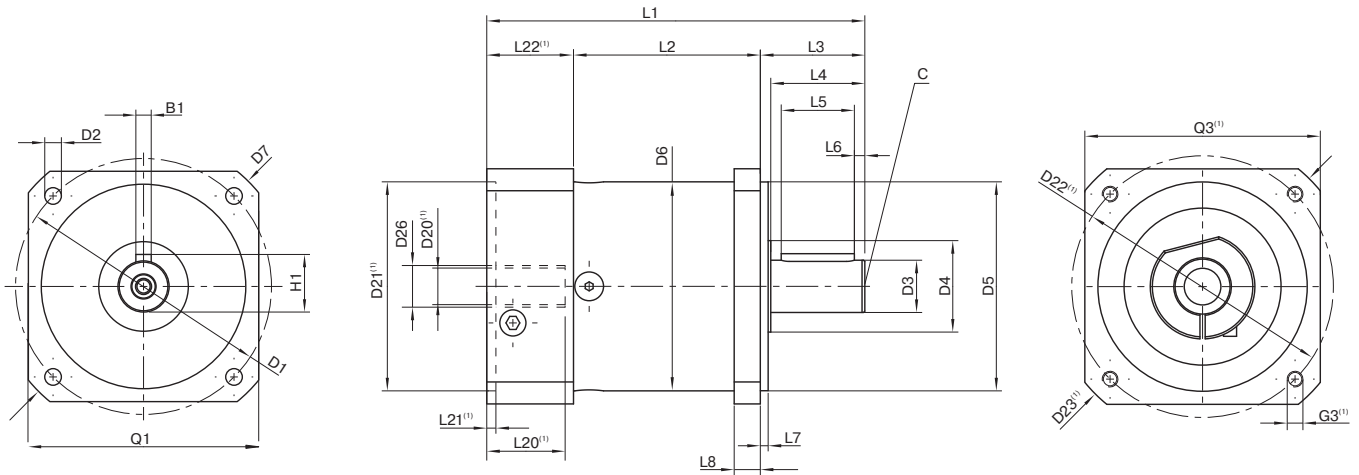

图示为带平键的 PLQE080 / 1 级 / 附带平键的输出轴 / 19 mm 锁紧系统 / 适配电机法兰 - 单一法兰 / B5 电机法兰类型
 Drawing corresponds to a PLQE080 / 1-stage / output shaft with feather key / 19 mm clamping system / motor adaptation - one part / B5 flange type motor

⁽¹⁾ 具体尺寸视电机/减速机法兰而定。可以在 www.neugart.com 下 Tec Data Finder 中针对每个电机适配电机特有的输入法兰几何尺寸。
⁽¹⁾ The dimensions vary with the motor/gearbox flange. The input flange dimensions can be retrieved for each specific motor in Tec Data Finder at www.neugart.com

几何尺寸 ⁽²⁾	Geometry ⁽²⁾			PLQE040	PLQE060	PLQE080	PLQE120	p ⁽³⁾	Code
输出端安装孔节圆直径	Pitch circle diameter output	D1		50	75	100	130		
输出端安装孔直径	Mounting bore output	D2	4x	3,4	5,5	6,5	8,5		
输出轴直径	Shaft diameter output	D3	h7	13	16	20	25		
输出轴轴肩直径	Shaft collar output	D4		17	20	35	35		
输出端定位凸台直径	Centering diameter output	D5	h7	35	60	80	110		
箱体直径	Housing diameter	D6		40	60	80	115		
输出法兰对角线尺寸	Diagonal dimension output	D7		57	92	116	145		
输出端法兰外方	Flange cross section output	Q1	■	42	70	90	115		
最小总长	Min. total length	L1		90	111	145	201,5	1	
				103	123,5	162,5	229,5	2	
				115,5	136	180	257	3	
箱体长度	Housing length	L2		35,5	55	71	99	1	
				48,5	67,5	89	127	2	
				61	80,5	106,5	154,5	3	
输出轴轴长	Shaft length output	L3		26	32	40	55		
输出端定位凸台深度	Centering depth output	L7		5,5	3	3	4		
输出端法兰厚度	Flange thickness output	L8		7	10	10	15		
电机轴直径 j6/k6	Motor shaft diameter j6/k6	D20		更多信息见第 163/164 页					
输入端锁紧系统直径	Clamping system diameter input	D26		More information on page 163/164					
带平键的输出轴 (DIN 6885-1)	Output shaft with feather key (DIN 6885-1)			A 5x5x14	A 5x5x20	A 6x6x28	A 8x7x40		A
平键宽度 (DIN 6885-1)	Feather key width (DIN 6885-1)	B1		5	5	6	8		
含平键在内的轴高 (DIN 6885-1)	Shaft height including feather key (DIN 6885-1)	H1		15	18	22,5	28		
到轴肩的距离	Shaft length from shoulder	L4		18	28	36	50		
平键长度	Feather key length	L5		14	20	28	40		
到轴端的距离	Distance from shaft end	L6		2	4	4	5		
中心孔 (DIN 332, DR 形)	Center hole (DIN 332, type DR)	C		M4x10	M5x12,5	M6x16	M10x22		
光滑输出轴	Smooth output shaft								B
到轴肩的距离	Shaft length from shoulder	L4		18	28	36	50		

⁽²⁾ 所有的尺寸单位为mm
⁽³⁾ 减速级数

⁽²⁾ Dimensions in mm
⁽³⁾ Number of stages

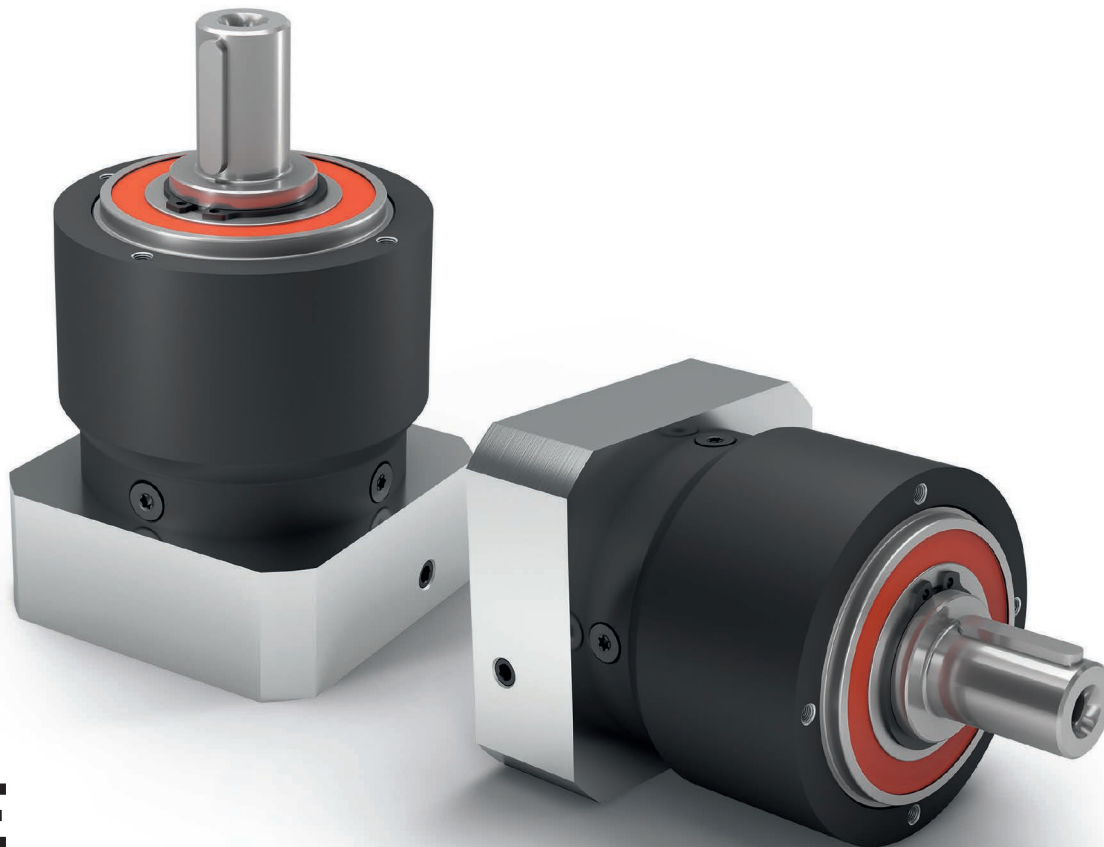

PLPE

经济型行星减速机 发热量低

我们的 **PLPE** 集中了经济型产品系列的最佳特性，而且性能更上一层楼。驱动装置的轴承经过优化设计，可以承受较高的径向力与轴向力。**PLPE** 紧凑的外轮廓使其可以在有限的空间条件下使用。

The cost effective planetary gearbox with the best torque-low heat performance

Our **PLPE** combines the best features of the Economy series with a performance bonus: The optimized output bearing is designed for higher radial and axial forces. The compact outer contour of the **PLPE** also allows it to be used in limited spaces.

额定扭矩
Nominal output torque **5-460 Nm**



径向力
Radial force **800 - 5200 N**



轴向力
Axial force **1000 - 7000 N**



回程间隙
Torsional backlash **7 - 19 arcmin**



防护等级
Protection class **IP54**



结构尺寸
Frame sizes



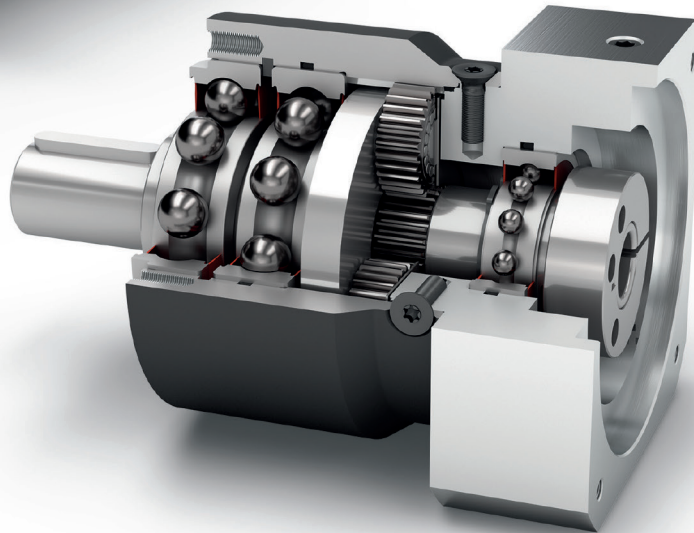
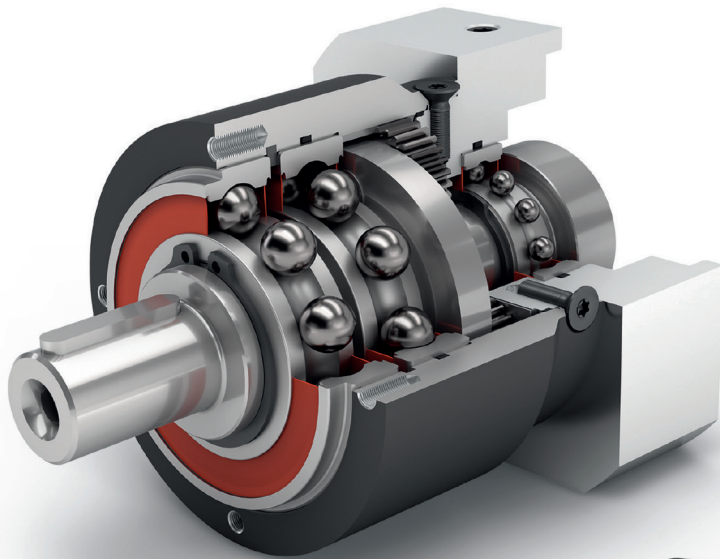

经济型
Economy Line



旋转方向 同方向
Equidirectional rotation

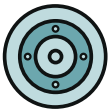

圆形输出法兰
Round type output flange



行星齿轮架
Planet carrier in disc design



可选: 装有小齿轮的高精度减速机
132页
Option: Planetary gearbox with
mounted pinion on page 132

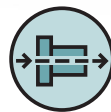

同轴减速机
Coaxial gearbox



直齿
Spur gear



增强深沟球轴承
Reinforced deep groove ball bearings



可选: 喷漆表面
——RAL 9005 黑色
Option: Painted surface
– RAL 9005 Jet black

技术特点的详细解释, 请从第173页读起。
Detailed explanations of the technical features starting on page 173.

Code	减速机参数	Gearbox characteristics			PLPE050	PLPE070	PLPE090	PLPE120	PLPE155	p ⁽¹⁾
	使用寿命 (L _{10h})	Service life (L _{10h})	t _L	h	30.000					
	满载时效率 ⁽²⁾	Efficiency at full load ⁽²⁾	η	%	98					1
					97					2
	最低工作温度	Min. operating temperature	T _{min}	°C	-25					
	最高工作温度	Max. operating temperature	T _{max}		90					
	防护等级	Protection class			IP54					
S	标准润滑	Standard lubrication			润滑脂(终生润滑) / Grease (lifetime lubrication)					
F	食品级润滑	Food grade lubrication			润滑脂(终生润滑) / Grease (lifetime lubrication)					
L	低温润滑 ⁽³⁾	Low temperature lubrication ⁽³⁾			润滑脂(终生润滑) / Grease (lifetime lubrication)					
	安装位置	Installation position			任意 / Any					
S	标准回程间隙	Standard backlash	j _t	arcmin	< 15	< 10	< 7	< 7	< 6	1
					< 19	< 12	< 9	< 9	< 9	2
	抗扭刚度 ⁽²⁾	Torsional stiffness ⁽²⁾	c _G	Nm / arcmin	0,7 - 1,0	3,5 - 6,7	9,7 - 18,5	24,5 - 52,5	54,5 - 96,0	1
					0,7 - 1,1	3,3 - 7,0	9,7 - 20,0	21,0 - 60,0	55,0 - 100,0	2
	减速机重量 ⁽²⁾	Gearbox weight ⁽²⁾	m _G	kg	0,6	1,4	3,2 - 3,3	7,4 - 7,7	16,7	1
					0,8	1,7 - 1,9	3,9 - 4,1	9,3 - 9,8	21,9 - 22,3	2
S	标准的箱体表面	Standard surface			箱体: 钢 - 热处理后氧化 (黑色) Housing: Steel - heat-treated and post-oxidized (black)					
B	喷漆表面	Painted surface			RAL 9005 黑色 RAL 9005 Jet black					
	运行噪音 ⁽⁴⁾	Running noise ⁽⁴⁾	Q _G	dB(A)	58	58	60	65	70	
	基于减速机输入法兰的最大弯矩 ⁽⁵⁾	Max. bending moment based on the gearbox input flange ⁽⁵⁾	M _b	Nm	4,5	12	16	40	180	

输出轴载荷	Output shaft loads			PLPE050	PLPE070	PLPE090	PLPE120	PLPE155	p ⁽¹⁾
20.000 h 径向力 ⁽⁶⁾⁽⁷⁾	Radial force for 20,000 h ⁽⁶⁾⁽⁷⁾	F _{r20.000h}	N	800	1050	1900	2500	5200	
20.000 h 轴向力 ⁽⁶⁾⁽⁷⁾	Axial force for 20,000 h ⁽⁶⁾⁽⁷⁾	F _{a20.000h}		1000	1350	2000	4000	7000	
30.000 h 径向力 ⁽⁶⁾⁽⁷⁾	Radial force for 30,000 h ⁽⁶⁾⁽⁷⁾	F _{r30.000h}		700	900	1700	2150	4600	
30.000 h 轴向力 ⁽⁶⁾⁽⁷⁾	Axial force for 30,000 h ⁽⁶⁾⁽⁷⁾	F _{a30.000h}		800	1000	1500	3000	6000	
最大径向力 ⁽⁷⁾⁽⁸⁾	Maximum radial force ⁽⁷⁾⁽⁸⁾	F _{rStat}		1300	1650	3100	4000	8400	
最大轴向力 ⁽⁷⁾⁽⁸⁾	Maximum axial force ⁽⁷⁾⁽⁸⁾	F _{aStat}		1000	2100	3800	5900	11000	
20.000 h 倾斜力矩 ⁽⁶⁾⁽⁸⁾	Tilting moment for 20,000 h ⁽⁶⁾⁽⁸⁾	M _{K20.000h}	Nm	26	43	99	168	497	
30.000 h 倾斜力矩 ⁽⁶⁾⁽⁸⁾	Tilting moment for 30,000 h ⁽⁶⁾⁽⁸⁾	M _{K30.000h}		23	36	89	144	440	

转动惯量	Moment of inertia			PLPE050	PLPE070	PLPE090	PLPE120	PLPE155	p ⁽¹⁾
转动惯量 ⁽²⁾	Mass moment of inertia ⁽²⁾	J	kgcm ²	0,015	0,069	0,374	1,419	4,932	1
				0,030	0,174	0,789	2,764	7,611	
				0,014	0,064	0,356	1,376	4,759	2
				0,026	0,126	0,625	2,334	7,108	

(1) 减速机级数
 (2) 传动比相关的数值可在 Tec Data Finder 中检索 - www.neugart.com
 (3) T_{min} = -40°C. 理想运行温度最高为 50°C
 (4) 距离减速机 1 m 时: 在输入转速为 n₁=3000 min⁻¹ 且无负荷时测得; i=5
 (5) 最大电机重量* (单位: kg) = 0.2 × M_b / 电机长度 (单位: m)
 * 电机重量对称分布
 * 水平和固定的安装位置
 (6) 数据以 n₂=100 min⁻¹ 的输出轴转速为准。
 (7) 以输出轴中心为准
 (8) 更改 T_{2N}, F_r, F_a 以及周期和轴承使用寿命时, 数值存在偏差 (部分较高)。利用 NCP 针对应用进行专门设计 - www.neugart.com

(1) Number of stages
 (2) The ratio-dependent values can be retrieved in Tec Data Finder - www.neugart.com
 (3) T_{min} = -40°C. Optimal operating temperature max. 50°C
 (4) Sound pressure level from 1 m, measured on input running at n₁=3000 rpm no load; i=5
 (5) Max. motor weight* in kg = 0.2 × M_b / motor length in m
 * with symmetrically distributed motor weight
 * with horizontal and stationary mounting
 (6) These values are based on an output shaft speed of n₂=100 rpm
 (7) Based on center of output shaft
 (8) Other (sometimes higher) values following changes to T_{2N}, F_r, F_a, cycle, and service life of bearing. Application specific configuration with NCP - www.neugart.com

输出扭矩	Output torques			PLPE050	PLPE070	PLPE090	PLPE120	PLPE155	i ⁽¹⁾	p ⁽²⁾
额定输出扭矩 ⁽³⁾⁽⁴⁾	Nominal output torque ⁽³⁾⁽⁴⁾	T _{2N}	Nm	11	28	85	115	-	3	1
				15	33	90	155	460	4	
				13	30	82	172	445	5	
				8,5	25	65	135	-	7	
				6	18	50	120	-	8	
				5	15	38	95	210	10	
				12	33	97	157	-	9	2
				15	33	90	195	-	12	
				13	33	82	172	-	15	
				15	33	90	195	460	16	
				15	33	90	195	460	20	
				13	30	82	172	445	25	
				15	33	90	195	-	32	
				13	30	82	172	460	40	
				-	-	-	-	445	50	
				7,5	18	50	120	-	64	
				5	15	38	95	210	100	
				17,5	45	136	184	-	3	
24	53	144	248	736	4					
21	48	131	275	712	5					
13,5	40	104	216	-	7					
9,5	29	80	192	-	8					
8	24	61	152	336	10					
19	53	155	251	-	9	2				
24	53	144	312	-	12					
21	53	131	275	-	15					
24	53	144	312	736	16					
24	53	144	312	736	20					
21	48	131	275	712	25					
24	53	144	312	-	32					
21	48	131	275	736	40					
-	-	-	-	712	50					
12	29	80	192	-	64					
8	24	61	152	336	100					

PLPE

⁽¹⁾ 传动比 (i=n₁/n₂)

⁽²⁾ 减速机级数

⁽³⁾ 利用 NCP 针对应用进行专门设计 – www.neugart.com

⁽⁴⁾ 平键 (代码 "A") 时的数值: 针对交变载荷

⁽⁵⁾ 允许输出轴转动30.000转: 参见第 166 页

⁽¹⁾ Ratios (i=n₁/n₂)

⁽²⁾ Number of stages

⁽³⁾ Application specific configuration with NCP – www.neugart.com

⁽⁴⁾ Values for feather key (code "A"): for repeated load

⁽⁵⁾ 30,000 rotations of the output shaft permitted; see page 167

PLPE

输出扭矩	Output torques			PLPE050	PLPE070	PLPE090	PLPE120	PLPE155	i ⁽¹⁾	p ⁽²⁾
急停扭矩 ⁽³⁾	Emergency stop torque ⁽³⁾	T _{2Stop}	Nm	22,5	66	180	390	-	3	1
				30	88	240	520	920	4	
				36	80	220	500	890	5	
				26	80	178	340	-	7	
				27	80	190	380	-	8	
				27	80	200	480	420	10	
			2	33	88	260	500	-	9	
				40	88	240	520	-	12	
				36	88	220	500	-	15	
				40	88	240	520	920	16	
				40	88	240	520	920	20	
				36	80	220	500	890	25	
				40	88	240	520	-	32	
				36	80	220	500	920	40	
				-	-	-	-	890	50	
				27	80	190	380	-	64	
				27	80	200	480	420	100	

输入转速	Input speeds			PLPE050	PLPE070	PLPE090	PLPE120	PLPE155	i ⁽¹⁾	p ⁽²⁾
T _{2N} 和 S1 时的平均热输入转速 ⁽⁴⁾⁽⁵⁾	Average thermal input speed at T _{2N} and S1 ⁽⁴⁾⁽⁵⁾	n _{1N}	min ⁻¹	5000	4500 ⁽⁶⁾	3250 ⁽⁶⁾	2650 ⁽⁶⁾	-	3	1
				5000	4500 ⁽⁶⁾	3750 ⁽⁶⁾	2800 ⁽⁶⁾	1800 ⁽⁶⁾	4	
				5000	4500	4000 ⁽⁶⁾	3100 ⁽⁶⁾	2150 ⁽⁶⁾	5	
				5000	4500	4000	3500 ⁽⁶⁾	-	7	
				5000	4500	4000	3500	-	8	
				5000	4500	4000	3500	3000	10	
				2	5000	4500	4000 ⁽⁶⁾	3500 ⁽⁶⁾	-	9
					5000	4500	4000	3500 ⁽⁶⁾	-	12
					5000	4500	4000	3500 ⁽⁶⁾	-	15
					5000	4500	4000	3500 ⁽⁶⁾	2900 ⁽⁶⁾	16
					5000	4500	4000	3500	3000 ⁽⁶⁾	20
					5000	4500	4000	3500	3000 ⁽⁶⁾	25
					5000	4500	4000	3500	-	32
					5000	4500	4000	3500	3000	40
					-	-	-	-	3000	50
					5000	4500	4000	3500	-	64
					5000	4500	4000	3500	3000	100
					最高机械输入转速 ⁽⁴⁾	Max. mechanical input speed ⁽⁴⁾	n _{1Limit}	min ⁻¹	18000	13000

⁽¹⁾ 传动比 (i=n₁/n₂)

⁽²⁾ 减速机级数

⁽³⁾ 允许 1000 次

⁽⁴⁾ 利用 NCP 针对应用设计转速 – www.neugart.com

⁽⁵⁾ 定义请参见第 166 页

⁽⁶⁾ 在 50% T_{2N} 输出和 S1 模式下的平均热输入转速

⁽¹⁾ Ratios (i=n₁/n₂)

⁽²⁾ Number of stages

⁽³⁾ Permitted 1000 times

⁽⁴⁾ Application-specific speed configurations with NCP – www.neugart.com

⁽⁵⁾ See page 167 for the definition

⁽⁶⁾ Average thermal input speed at 50% T_{2N} and S1

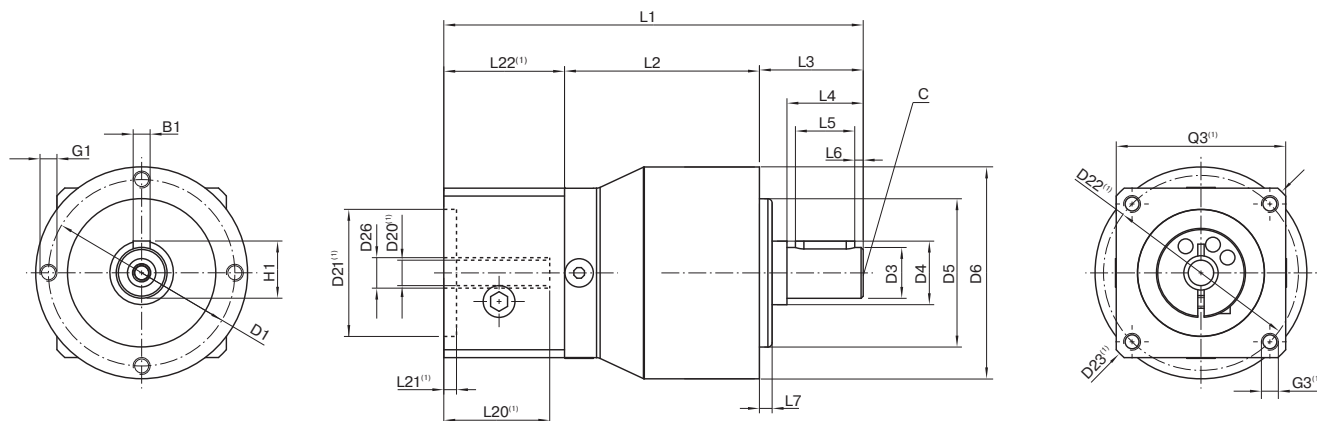

图示为带平键的 PLPE050 / 1 级 / 附带平键的输出轴 / 8 mm 锁紧系统 / 适配电机法兰 - 单一法兰 / B5 电机法兰类型
 Drawing corresponds to a PLPE050 / 1-stage / output shaft with feather key / 8 mm clamping system / motor adaptation – one part / B5 flange type motor

⁽¹⁾具体尺寸视电机/减速机法兰而定。可以在 www.neugart.com 下 Tec Data Finder 中针对每个电机适配电机特有的输入法兰几何尺寸。
⁽¹⁾ The dimensions vary with the motor/gearbox flange. The input flange dimensions can be retrieved for each specific motor in Tec Data Finder at www.neugart.com

几何尺寸 ⁽²⁾	Geometry ⁽²⁾			PLPE050	PLPE070	PLPE090	PLPE120	PLPE155	p ⁽³⁾	Code
输出端安装孔节圆直径	Pitch circle diameter output	D1		44	62	80	108	140		
输出轴直径	Shaft diameter output	D3	k7	12	16	22	32	40		
输出轴轴肩直径	Shaft collar output	D4		15	30	35	50	55		
输出端定位凸台直径	Centering diameter output	D5	h7	35	52	68	90	120		
箱体直径	Housing diameter	D6		50	70	90	120	155		
安装螺纹 x 深度	Mounting thread x depth	G1	4x	M4x8	M5x8	M6x9	M8x20	M10x20		
最小总长	Min. total length	L1		94	111	147	192	275,5	1	
				106,5	124	165	219,5	320	2	
箱体长度	Housing length	L2		46	51	67,5	76,5	100	1	
				58,5	64	85	104	144,5	2	
输出轴轴长	Shaft length output	L3		24,5	36	46	68	97		
输出端定位凸台深度	Centering depth output	L7		3	3	4	5	8		
电机轴直径 j6/k6	Motor shaft diameter j6/k6	D20		更多信息见第 163/164 页 More information on page 163/164						
输入端锁紧系统直径	Clamping system diameter input	D26		更多信息见第 163/164 页 More information on page 163/164						
带平键的输出轴 (DIN 6885-1)	Output shaft with feather key (DIN 6885-1)			A 4x4x14	A 5x5x25	A 6x6x32	A 10x8x50	A 12x8x70		A
平键宽度 (DIN 6885-1)	Feather key width (DIN 6885-1)	B1		4	5	6	10	12		
含平键在内的轴高 (DIN 6885-1)	Shaft height including feather key (DIN 6885-1)	H1		13,5	18	24,5	35	43		
到轴肩的距离	Shaft length from shoulder	L4		18	28	36	58	82		
平键长度	Feather key length	L5		14	25	32	50	70		
到轴端的距离	Distance from shaft end	L6		2	2	2	4	6		
中心孔 (DIN 332, DR 形)	Center hole (DIN 332, type DR)	C			M4x10	M5x12,5	M8x19	M12x28	M16x36	
光滑输出轴	Smooth output shaft									B
到轴肩的距离	Shaft length from shoulder	L4		18	28	36	58	82		

⁽²⁾ 所有的尺寸单位为mm
⁽³⁾ 减速机级数

⁽²⁾ Dimensions in mm
⁽³⁾ Number of stages

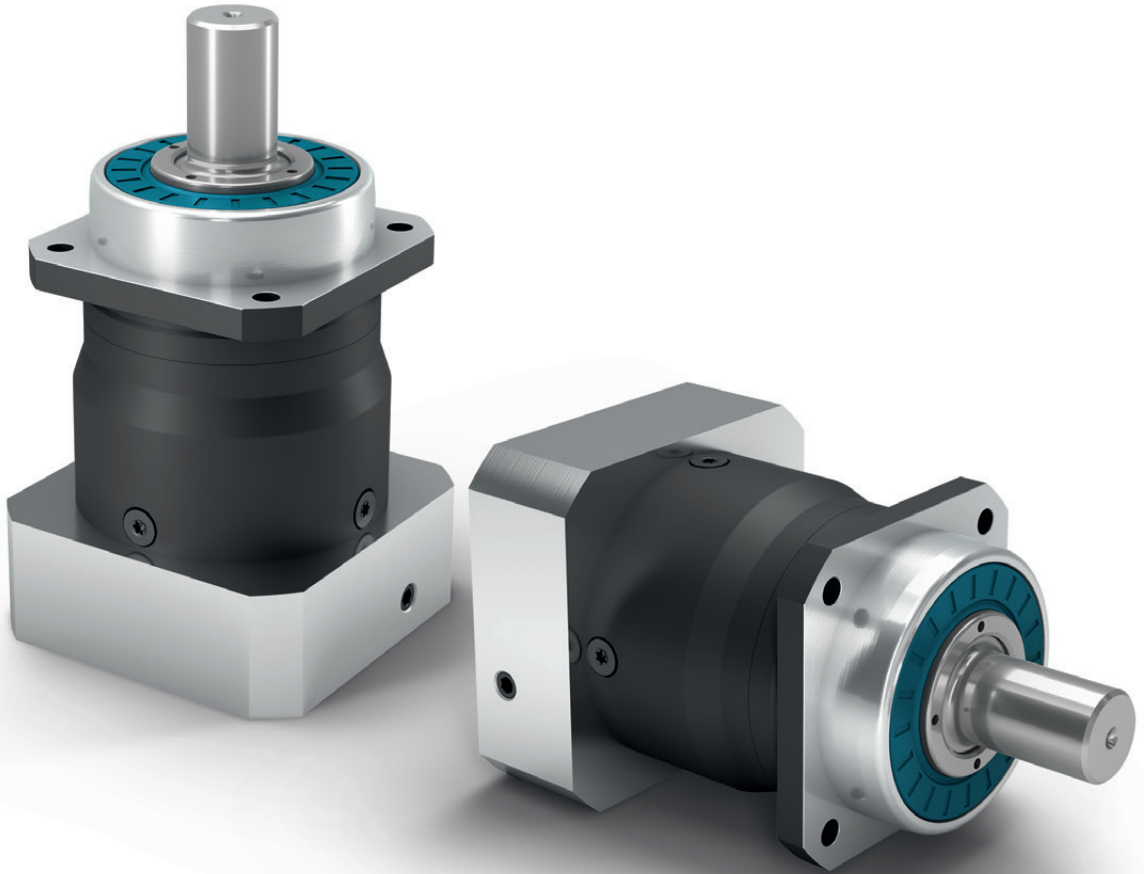

PLHE

这款行星减速机的进步之处在于：
集高精度和
经济性于一身

PLHE 是经济型减速机与高精度减速机的理想组合。这种行星减速机装有预胀紧的圆锥滚子轴承，确保在承受极大的负荷时仍然具有较高的刚性。高性能的密封提高了防尘和防喷淋水性能。

This is progress:
In this planetary gearbox, precision
and cost effectiveness meet

The **PLHE** is our ideal combination of economy and precision gearboxes. The preloaded tapered roller bearings of this planetary gearbox guarantee high rigidity even under maximum load. The high-performance seal provides increased protection against dust and water spray.

额定扭矩 Nominal output torque	15 - 260 Nm
径向力 Radial force	3200 - 6000 N
轴向力 Axial force	4400 - 8000 N
回程间隙 Torsional backlash	7 - 12 arcmin
防护等级 Protection class	IP65

结构尺寸
Frame sizes



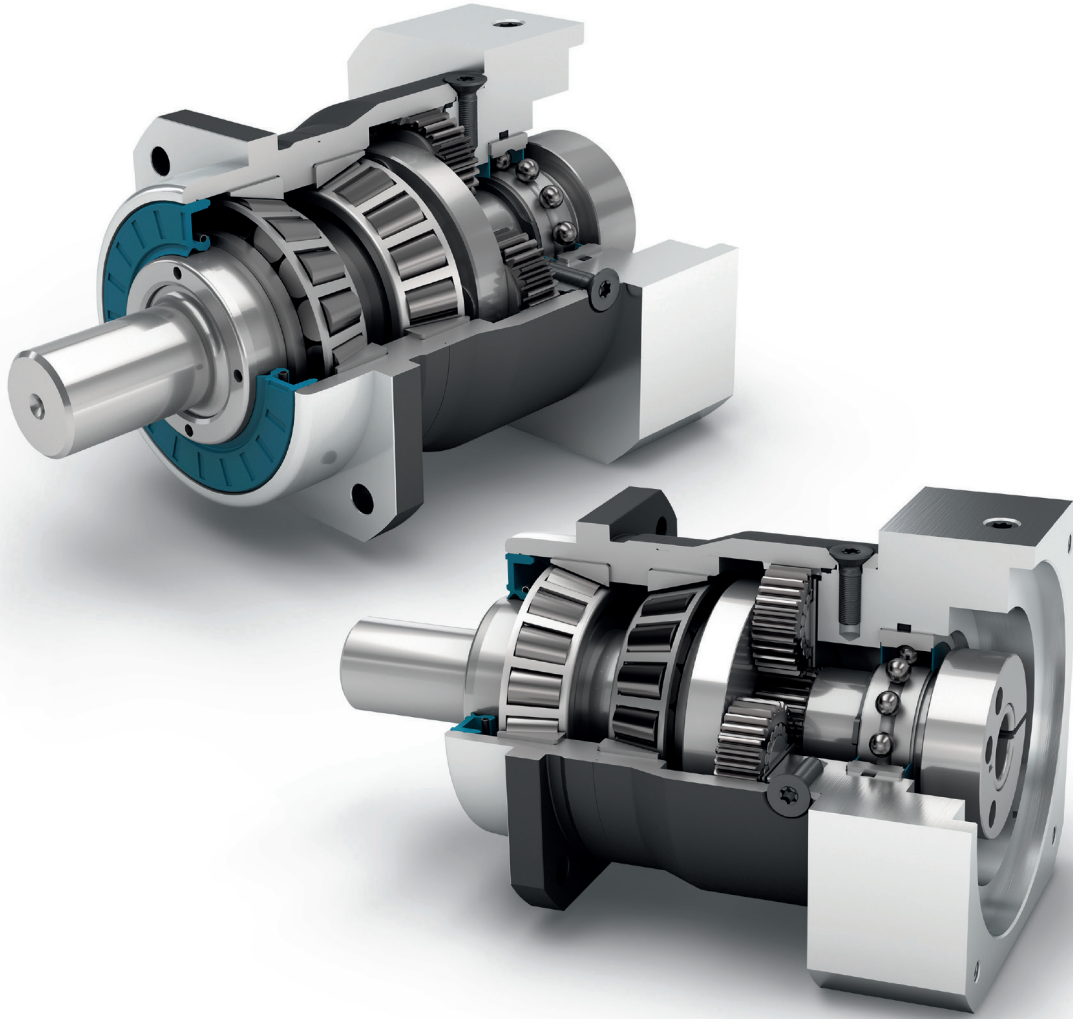

经济型
Economy Line



旋转方向 同方向
Equidirectional rotation

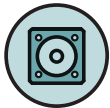

正方形输出法兰
Square type output flange



径向轴密封
Rotary shaft seal



行星齿轮架
Planet carrier in disc design



0可选：装有小齿轮的高精度减速机
132页
Option: Planetary gearbox with
mounted pinion on page 132



同轴减速机
Coaxial gearbox



直齿
Spur gear



配有预紧的圆锥滚子轴承
Preloaded tapered roller bearings



输出端带有超长定心环
Extra long centering collar



可选：花键输出轴 (DIN 5480)
Option: Splined output shaft (DIN 5480)



可选：喷漆表面
——RAL 9005 黑色
Option: Painted surface
– RAL 9005 Jet black

技术特点的详细解释，请从第173页读起。
Detailed explanations of the technical features starting on page 173.

Code	减速机参数	Gearbox characteristics			PLHE060	PLHE080	PLHE120	p ⁽¹⁾
	使用寿命 (L _{10h})	Service life (L _{10h})	t _L	h	30.000			
	满载时效率 ⁽²⁾	Efficiency at full load ⁽²⁾	η	%	97			1
					96			2
	最低工作温度	Min. operating temperature	T _{min}	°C	-25			
	最高工作温度	Max. operating temperature	T _{max}		90			
	防护等级	Protection class			IP65			
S	标准润滑	Standard lubrication			润滑脂(终生润滑) / Grease (lifetime lubrication)			
F	食品级润滑	Food grade lubrication			润滑脂(终生润滑) / Grease (lifetime lubrication)			
L	低温润滑 ⁽³⁾	Low temperature lubrication ⁽³⁾			润滑脂(终生润滑) / Grease (lifetime lubrication)			
	安装位置	Installation position			任意 / Any			
S	标准回程间隙	Standard backlash	j _t	arcmin	< 10	< 7	< 7	1
					< 12	< 9	< 9	2
	抗扭刚度 ⁽²⁾	Torsional stiffness ⁽²⁾	c _G	Nm / arcmin	2,6 - 4,4	7,3 - 11,6	18,5 - 26,0	1
					2,5 - 4,6	7,3 - 12,3	16,7 - 27,5	2
	减速机重量 ⁽²⁾	Gearbox weight ⁽²⁾	m _G	kg	1,5 - 1,6	3,0 - 3,1	6,8 - 7,1	1
					1,7 - 1,8	3,5 - 3,6	8,5 - 9,0	2
S	标准的箱体表面	Standard surface			箱体: 钢 - 热处理后氧化 (黑色) Housing: Steel - heat-treated and post-oxidized (black)			
B	喷漆表面	Painted surface			RAL 9005 黑色 RAL 9005 Jet black			
	运行噪音 ⁽⁴⁾	Running noise ⁽⁴⁾	Q _G	dB(A)	58	60	65	
	基于减速机输入法兰的最大弯矩 ⁽⁵⁾	Max. bending moment based on the gearbox input flange ⁽⁵⁾	M _b	Nm	8	16	40	

输出轴载荷	Output shaft loads			PLHE060	PLHE080	PLHE120	p ⁽¹⁾
20.000 h 径向力 ⁽⁶⁾⁽⁷⁾	Radial force for 20,000 h ⁽⁶⁾⁽⁷⁾	F _{r 20.000 h}	N	3200	5500	6000	
20.000 h 轴向力 ⁽⁶⁾⁽⁷⁾	Axial force for 20,000 h ⁽⁶⁾⁽⁷⁾	F _{a 20.000 h}		4400	6400	8000	
30.000 h 径向力 ⁽⁶⁾⁽⁷⁾	Radial force for 30,000 h ⁽⁶⁾⁽⁷⁾	F _{r 30.000 h}		3200	4800	5400	
30.000 h 轴向力 ⁽⁶⁾⁽⁷⁾	Axial force for 30,000 h ⁽⁶⁾⁽⁷⁾	F _{a 30.000 h}		3900	5700	7000	
最大径向力 ⁽⁷⁾⁽⁸⁾	Maximum radial force ⁽⁷⁾⁽⁸⁾	F _{r Stat}		3200	5500	6000	
最大轴向力 ⁽⁷⁾⁽⁸⁾	Maximum axial force ⁽⁷⁾⁽⁸⁾	F _{a Stat}		4400	6400	8000	
20.000 h 倾斜力矩 ⁽⁶⁾⁽⁸⁾	Tilting moment for 20,000 h ⁽⁶⁾⁽⁸⁾	M _{K 20.000 h}	Nm	191	383	488	
30.000 h 倾斜力矩 ⁽⁶⁾⁽⁸⁾	Tilting moment for 30,000 h ⁽⁶⁾⁽⁸⁾	M _{K 30.000 h}		191	335	439	

转动惯量	Moment of inertia			PLHE060	PLHE080	PLHE120	p ⁽¹⁾
转动惯量 ⁽²⁾	Mass moment of inertia ⁽²⁾	J	kgcm ²	0,069 - 0,178	0,370 - 0,775	1,390 - 2,486	1
				0,064 - 0,135	0,357 - 0,641	1,378 - 2,326	2

(1) 减速机级数

(2) 传动比相关的数值可在 Tec Data Finder 中检索 - www.neugart.com

(3) T_{min} = -40°C. 理想运行温度最高为 50°C

(4) 距离减速机 1 m 时: 在输入转速为 n₁=3000 min⁻¹ 且无负荷时测得; i=5

(5) 最大电机重量* (单位: kg) = 0.2 × M_b / 电机长度 (单位: m)

* 电机重量对称分布

* 水平和固定的安装位置

(6) 数据以 n₂=100 min⁻¹ 的输出轴转速为准。

(7) 以输出轴中心为准

(8) 更改 T_{2N}, F_r, F_a 以及周期和轴承使用寿命时, 数值存在偏差 (部分较高)。利用 NCP 针对应用进行专门设计 - www.neugart.com

(1) Number of stages

(2) The ratio-dependent values can be retrieved in Tec Data Finder - www.neugart.com

(3) T_{min} = -40°C. Optimal operating temperature max. 50°C

(4) Sound pressure level from 1 m, measured on input running at n₁=3000 rpm no load; i=5

(5) Max. motor weight* in kg = 0.2 × M_b / motor length in m

* with symmetrically distributed motor weight

* with horizontal and stationary mounting

(6) These values are based on an output shaft speed of n₂=100 rpm

(7) Based on center of output shaft

(8) Other (sometimes higher) values following changes to T_{2N}, F_r, F_a, cycle, and service life of bearing. Application specific configuration with NCP - www.neugart.com

输出扭矩	Output torques			PLHE060	PLHE080	PLHE120	$i^{(1)}$	$p^{(2)}$
额定输出扭矩 ⁽³⁾⁽⁴⁾	Nominal output torque ⁽³⁾⁽⁴⁾	T_{2N}	Nm	28	85	115	3	1
				38	115	155	4	
				40	110	195	5	
				25	65	135	7	
				18	50	120	8	
				15	38	95	10	
				44	130	210	9	2
				44	120	260	12	
				44	110	230	15	
				44	120	260	16	
				44	120	260	20	
				40	110	230	25	
				44	120	260	32	
				40	110	230	40	
				18	50	120	64	
				15	38	95	100	
最大输出扭矩 ⁽⁴⁾⁽⁵⁾	Max. output torque ⁽⁴⁾⁽⁵⁾	T_{2max}	Nm	45	136	184	3	1
				61	184	248	4	
				64	176	312	5	
				40	104	216	7	
				29	80	192	8	
				24	61	152	10	
				70	208	336	9	2
				70	192	416	12	
				70	176	368	15	
				70	192	416	16	
				70	192	416	20	
				64	176	368	25	
				70	192	416	32	
				64	176	368	40	
29	80	192	64					
24	61	152	100					

PLHE

⁽¹⁾ 传动比 ($i=n_1/n_2$)

⁽²⁾ 减速机级数

⁽³⁾ 利用 NCP 针对应用进行专门设计 - www.neugart.com

⁽⁴⁾ 平键 (代码 "A") 时的数值: 针对交变载荷

⁽⁵⁾ 允许输出轴转动30.000转; 参见第 166 页

⁽¹⁾ Ratios ($i=n_1/n_2$)

⁽²⁾ Number of stages

⁽³⁾ Application specific configuration with NCP - www.neugart.com

⁽⁴⁾ Values for feather key (code "A"): for repeated load

⁽⁵⁾ 30,000 rotations of the output shaft permitted; see page 167

输出扭矩	Output torques			PLHE060	PLHE080	PLHE120	$i^{(1)}$	$p^{(2)}$
急停扭矩 ⁽³⁾	Emergency stop torque ⁽³⁾	T_{2Stop}	Nm	66	180	390	3	1
				88	240	520	4	
				80	220	500	5	
				80	178	340	7	
				80	190	380	8	
				80	200	480	10	
				88	260	500	9	2
				88	240	520	12	
				88	220	500	15	
				88	240	520	16	
				88	240	520	20	
				80	220	500	25	
				88	240	520	32	
				80	220	500	40	
				80	190	380	64	
				80	200	480	100	

输入转速	Input speeds			PLHE060	PLHE080	PLHE120	$i^{(1)}$	$p^{(2)}$
T_{2N} 和 S1 时的平均热输入转速 ⁽⁴⁾⁽⁵⁾	Average thermal input speed at T_{2N} and S1 ⁽⁴⁾⁽⁵⁾	n_{1N}	min^{-1}	2950 ⁽⁶⁾	2450 ⁽⁶⁾	2150 ⁽⁶⁾	3	1
				3500 ⁽⁶⁾	2700 ⁽⁶⁾	2400 ⁽⁶⁾	4	
				4200 ⁽⁶⁾	3250 ⁽⁶⁾	2600 ⁽⁶⁾	5	
				4500	4000	3500 ⁽⁶⁾	7	
				4500	4000	3500 ⁽⁶⁾	8	
				4500	4000	3500	10	
				4500 ⁽⁶⁾	4000 ⁽⁶⁾	3050 ⁽⁶⁾	9	2
				4500	4000 ⁽⁶⁾	3200 ⁽⁶⁾	12	
				4500	4000	3500 ⁽⁶⁾	15	
				4500	4000	3500 ⁽⁶⁾	16	
				4500	4000	3500 ⁽⁶⁾	20	
				4500	4000	3500	25	
				4500	4000	3500	32	
				4500	4000	3500	40	
				4500	4000	3500	64	
				4500	4000	3500	100	
				最高机械输入转速 ⁽⁴⁾	Max. mechanical input speed ⁽⁴⁾	n_{1Limit}	min^{-1}	

⁽¹⁾ 传动比 ($i=n_1/n_2$)

⁽²⁾ 减速机级数

⁽³⁾ 允许 1000 次

⁽⁴⁾ 利用 NCP 针对应用设计转速 – www.neugart.com

⁽⁵⁾ 定义请参见第 166 页

⁽⁶⁾ 在 50% T_{2N} 输出和 S1 模式下的平均热输入转速

⁽¹⁾ Ratios ($i=n_1/n_2$)

⁽²⁾ Number of stages

⁽³⁾ Permitted 1000 times

⁽⁴⁾ Application-specific speed configurations with NCP – www.neugart.com

⁽⁵⁾ See page 167 for the definition

⁽⁶⁾ Average thermal input speed at 50% T_{2N} and S1

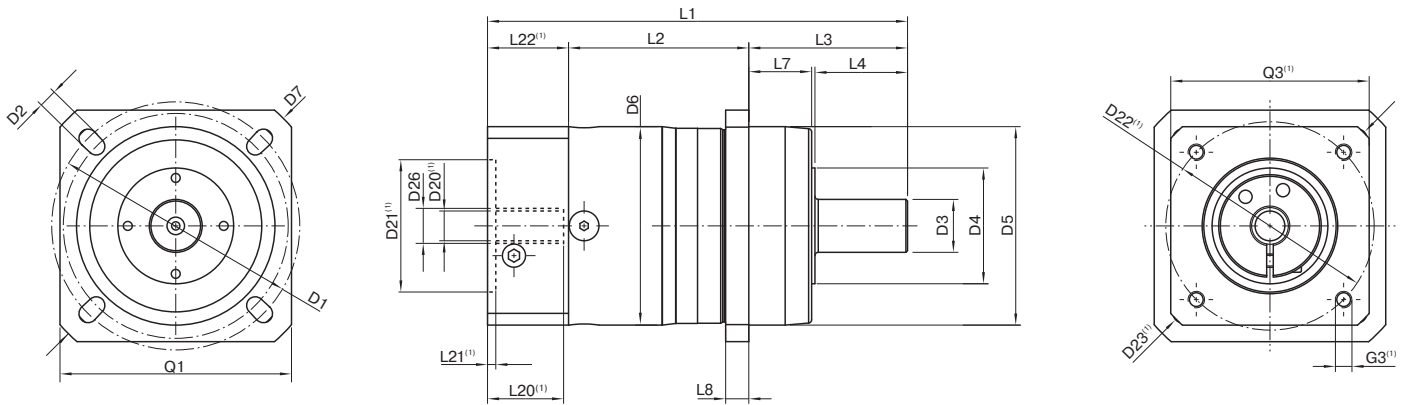

图示为带平键的 PLHE060 / 1 级 / 光滑输出轴 / 11 mm 锁紧系统 / 适配电机法兰 - 单一法兰 / B5 电机法兰类型
 Drawing corresponds to a PLHE060 / 1-stage / smooth output shaft / 11 mm clamping system / motor adaptation - one part / B5 flange type motor

⁽¹⁾ 具体尺寸视电机/减速机法兰而定。可以在 www.neugart.com 下 Tec Data Finder 中针对每个电机适配电机特有的输入法兰几何尺寸。
⁽¹⁾ The dimensions vary with the motor/gearbox flange. The input flange dimensions can be retrieved for each specific motor in Tec Data Finder at www.neugart.com

几何尺寸 ⁽²⁾	Geometry ⁽²⁾			PLHE060	PLHE080	PLHE120	p ⁽³⁾	Code
输出端安装孔节圆直径	Pitch circle diameter output	D1		68 - 75	85	120		
输出端安装孔直径	Mounting bore output	D2	4x	5,5	6,5	9,0		
输出轴直径	Shaft diameter output	D3	k6	16	22	32		
输出轴轴肩直径	Shaft collar output	D4		35	40	45		
输出端定位凸台直径	Centering diameter output	D5	g7	60	70	90		
箱体直径	Housing diameter	D6		60	80	115		
输出法兰对角线尺寸	Diagonal dimension output	D7		92	100	140		
输出端法兰外方	Flange cross section output	Q1	■	70	80	110		
最小总长	Min. total length	L1		127	159	199,5	1	
				139,5	177	227	2	
箱体长度	Housing length	L2		55	69,5	64	1	
				67,5	87	91,5	2	
输出轴轴长	Shaft length output	L3		48	56	88		
输出端定位凸台深度	Centering depth output	L7		19	17,5	28		
输出端法兰厚度	Flange thickness output	L8		7	8	10		
电机轴直径j6/k6	Motor shaft diameter j6/k6	D20		更多信息见第 163/164 页 More information on page 163/164				
输入端锁紧系统直径	Clamping system diameter input	D26						
带平键的输出轴 (DIN 6885-1)	Output shaft with feather key (DIN 6885-1)			A 5x5x25	A 6x6x28	A 10x8x50		A
平键宽度 (DIN 6885-1)	Feather key width (DIN 6885-1)	B1		5	6	10		
含平键在内的轴高 (DIN 6885-1)	Shaft height including feather key (DIN 6885-1)	H1		18	24,5	35		
到轴肩的距离	Shaft length from shoulder	L4		28	36	58		
平键长度	Feather key length	L5		25	28	50		
到轴端的距离	Distance from shaft end	L6		2	4	4		
中心孔 (DIN 332, DR 形)	Center hole (DIN 332, type DR)	C		M5x12,5	M8x19	M12x28		
光滑输出轴	Smooth output shaft							
到轴肩的距离	Shaft length from shoulder	L4		28	36	58		B
花键输出轴 (DIN 5480)	Splined output shaft (DIN 5480)			W16x0,8x18x6m	W22x1,25x16x6m	W32x1,25x24x6m		C
花键或键槽的长度	Width of gearing	L _v		15	15	15		
输出轴轴长	Shaft length output	L3		48	56	88		
到轴肩的距离	Shaft length from shoulder	L4		26	26	26		
中心孔 (DIN 332, DR 形)	Center hole (DIN 332, type DR)	C		M5x12,5	M8x19	M12x28		

⁽²⁾ 所有的尺寸单位为mm
⁽³⁾ 减速机级数

⁽²⁾ Dimensions in mm
⁽³⁾ Number of stages

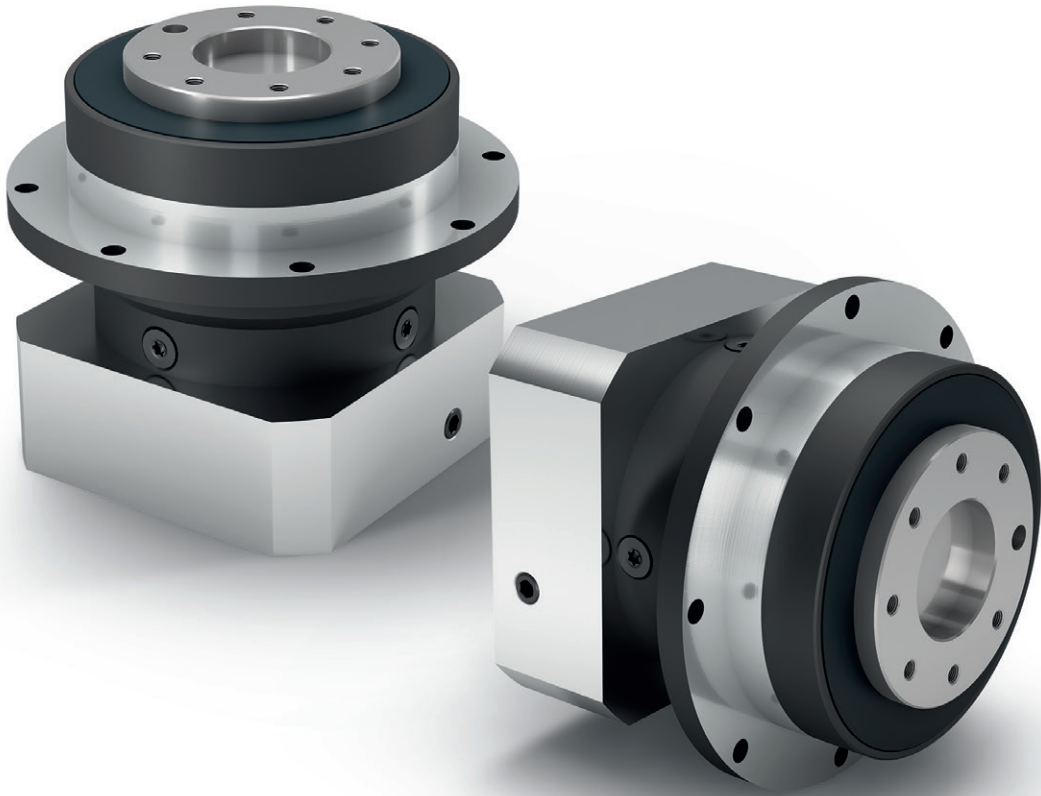

PLFE

最短的行星减速机，具备较高的抗扭刚度，带有法兰输出轴

前所未有的紧凑结构：**PLFE** 是我们带有紧凑型法兰输出轴的行星减速机。您可以节省三分之一以上的空间。它带有标准法兰接口，因此特别容易安装。它还集成了定位销孔，在安装时增加了牢固度。

The shortest planetary gearbox with high torsional stiffness and flange output shaft

There is no such thing as too short: The **PLFE** is our planetary gearbox with compact flange output shaft. They are more than one-third smaller in size. Its standardized flange interface makes it particularly easy to install. The integrated dowel pin drill hole provides additional stability during installation.

额定扭矩 Nominal output torque	5 - 260 Nm
径向力 Radial force	550 - 2400 N
轴向力 Axial force	480 - 3300 N
回程间隙 Torsional backlash	7 - 15 arcmin
防护等级 Protection class	IP54

结构尺寸 Frame sizes





经济型
Economy Line

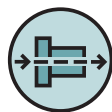

同轴减速机
Coaxial gearbox



直齿
Spur gear



低摩擦深沟球轴承
Low-friction deep groove ball bearings



行星齿轮架
Planet carrier in disc design



旋转方向 同方向
Equidirectional rotation



圆形特大号输出法兰
Extra large round type output flange



法兰输出轴 (按 ISO 9409-1 标准)
Flange output shaft (ISO 9409-1)



可选: 喷漆表面
——RAL 9005 黑色
Option: Painted surface
- RAL 9005 Jet black

技术特点的详细解释, 请从第173页读起。
Detailed explanations of the technical features starting on page 173.

Code	减速机参数	Gearbox characteristics			PLFE055	PLFE064	PLFE090	PLFE110	p ⁽¹⁾
	使用寿命 (L _{10h})	Service life (L _{10h})	t _L	h	30.000				
	满载时效率 ⁽²⁾	Efficiency at full load ⁽²⁾	η	%	98				1
					97				2
	最低工作温度	Min. operating temperature	T _{min}	°C	-25				
	最高工作温度	Max. operating temperature	T _{max}		90				
	防护等级	Protection class			IP54				
S	标准润滑	Standard lubrication			润滑脂(终生润滑) / Grease (lifetime lubrication)				
F	食品级润滑	Food grade lubrication			润滑脂(终生润滑) / Grease (lifetime lubrication)				
L	低温润滑 ⁽³⁾	Low temperature lubrication ⁽³⁾			润滑脂(终生润滑) / Grease (lifetime lubrication)				
	安装位置	Installation position			任意 / Any				
S	标准回程间隙	Standard backlash	j _t	arcmin	< 15	< 10	< 7	< 7	1
					< 19	< 12	< 9	< 9	2
	抗扭刚度 ⁽²⁾	Torsional stiffness ⁽²⁾	c _G	Nm / arcmin	1,7 - 4,1	5,5 - 11,0	16,3 - 33,5	36,0 - 72,0	1
					1,5 - 5,6	5,1 - 11,9	15,9 - 39,5	29,5 - 88,0	2
	减速机重量 ⁽²⁾	Gearbox weight ⁽²⁾	m _G	kg	0,7	1,1	3,0	6,4 - 6,7	1
					0,8	1,3 - 1,4	3,4 - 3,7	8,1 - 8,6	2
S	标准的箱体表面	Standard surface			箱体: 钢 - 热处理后氧化 (黑色) Housing: Steel - heat-treated and post-oxidized (black)				
B	喷漆表面	Painted surface			RAL 9005 黑色 RAL 9005 Jet black				
	运行噪音 ⁽⁴⁾	Running noise ⁽⁴⁾	Q _G	dB(A)	58	58	60	65	
	基于减速机输入法兰的最大弯矩 ⁽⁵⁾	Max. bending moment based on the gearbox input flange ⁽⁵⁾	M _b	Nm	4,5	12	16	40	

输出轴载荷	Output shaft loads			PLFE055	PLFE064	PLFE090	PLFE110	p ⁽¹⁾
20.000 h 径向力 ⁽⁶⁾⁽⁷⁾	Radial force for 20,000 h ⁽⁶⁾⁽⁷⁾	F _{r20.000h}	N	550	550	1400	2400	
20.000 h 轴向力 ⁽⁶⁾⁽⁷⁾	Axial force for 20,000 h ⁽⁶⁾⁽⁷⁾	F _{a20.000h}		840	1200	3000	3300	
30.000 h 径向力 ⁽⁶⁾⁽⁷⁾	Radial force for 30,000 h ⁽⁶⁾⁽⁷⁾	F _{r30.000h}		480	500	1200	2100	
30.000 h 轴向力 ⁽⁶⁾⁽⁷⁾	Axial force for 30,000 h ⁽⁶⁾⁽⁷⁾	F _{a30.000h}		710	1200	3000	3300	
最大径向力 ⁽⁷⁾⁽⁸⁾	Maximum radial force ⁽⁷⁾⁽⁸⁾	F _{r Stat}		1150	900	2200	3800	
最大轴向力 ⁽⁷⁾⁽⁸⁾	Maximum axial force ⁽⁷⁾⁽⁸⁾	F _{a Stat}		1000	1200	3300	5200	
20.000 h 倾斜力矩 ⁽⁶⁾⁽⁸⁾	Tilting moment for 20,000 h ⁽⁶⁾⁽⁸⁾	M _{K20.000h}	Nm	12	12	46	109	
30.000 h 倾斜力矩 ⁽⁶⁾⁽⁸⁾	Tilting moment for 30,000 h ⁽⁶⁾⁽⁸⁾	M _{K30.000h}		11	11	40	96	

转动惯量	Moment of inertia			PLFE055	PLFE064	PLFE090	PLFE110	p ⁽¹⁾
转动惯量 ⁽²⁾	Mass moment of inertia ⁽²⁾	J	kgcm ²	0,018 - 0,064	0,072 - 0,210	0,406 - 1,164	1,484 - 3,430	1
				0,014 - 0,030	0,064 - 0,130	0,356 - 0,666	1,377 - 2,407	2

(1) 减速机级数

(2) 传动比相关的数值可在 Tec Data Finder 中检索 - www.neugart.com

(3) T_{min} = -40°C. 理想运行温度最高为 50°C

(4) 距离减速机 1 m 时: 在输入转速为 n₁=3000 min⁻¹ 且无负荷时测得: i=5

(5) 最大电机重量* (单位: kg) = 0.2 × M_b / 电机长度 (单位: m)

* 电机重量对称分布

* 水平和固定的安装位置

(6) 数据以 n₂=100 min⁻¹ 的输出轴转速为准。

(7) 以输出轴中心为准

(8) 更改 T_{2N}, F_r, F_a 以及周期和轴承使用寿命时, 数值存在偏差 (部分较高)。利用 NCP 针对应用进行专门设计 - www.neugart.com

(1) Number of stages

(2) The ratio-dependent values can be retrieved in Tec Data Finder - www.neugart.com

(3) T_{min} = -40°C. Optimal operating temperature max. 50°C

(4) Sound pressure level from 1 m, measured on input running at n₁=3000 rpm no load; i=5

(5) Max. motor weight* in kg = 0.2 × M_b / motor length in m

* with symmetrically distributed motor weight

* with horizontal and stationary mounting

(6) These values are based on an output shaft speed of n₂=100 rpm

(7) Based on the end of the output shaft

(8) Other (sometimes higher) values following changes to T_{2N}, F_r, F_a, cycle, and service life of bearing. Application specific configuration with NCP - www.neugart.com

输出扭矩	Output torques			PLFE055	PLFE064	PLFE090	PLFE110	i ⁽¹⁾	p ⁽²⁾
额定输出扭矩 ⁽³⁾	Nominal output torque ⁽³⁾	T _{2N}	Nm	11	28	85	115	3	1
				15	38	115	155	4	
				14	40	110	195	5	
				8,5	25	65	135	7	
				6	18	50	120	8	
				5	15	38	95	10	
				16,5	44	130	210	9	2
				20	44	120	260	12	
				18	44	110	230	15	
				20	44	120	260	16	
				20	44	120	260	20	
				18	40	110	230	25	
				20	44	120	260	32	
				18	40	110	230	40	
				7,5	18	50	120	64	
				5	15	38	95	100	
最大输出扭矩 ⁽⁴⁾	Max. output torque ⁽⁴⁾	T _{2max}	Nm	17,5	45	136	184	3	1
				24	61	184	248	4	
				22	64	176	312	5	
				13,5	40	104	216	7	
				10	29	80	192	8	
				8	24	61	152	10	
				26	70	208	336	9	2
				32	70	192	416	12	
				29	70	176	368	15	
				32	70	192	416	16	
				32	70	192	416	20	
				29	64	176	368	25	
				32	70	192	416	32	
				29	64	176	368	40	
				12	29	80	192	64	
				8	24	61	152	100	

PLFE

⁽¹⁾ 传动比 (i=n₁/n₂)

⁽²⁾ 减速机级数

⁽³⁾ 利用 NCP 针对应用进行专门设计 – www.neugart.com

⁽⁴⁾ 允许输出轴转动30.000转; 参见第 166 页

⁽¹⁾ Ratios (i=n₁/n₂)

⁽²⁾ Number of stages

⁽³⁾ Application specific configuration with NCP – www.neugart.com

⁽⁴⁾ 30,000 rotations of the output shaft permitted; see page 167

输出扭矩	Output torques			PLFE055	PLFE064	PLFE090	PLFE110	i ⁽¹⁾	p ⁽²⁾
急停扭矩 ⁽³⁾	Emergency stop torque ⁽³⁾	T _{2Stop}	Nm	22,5	66	180	390	3	1
				30	88	240	520	4	
				36	80	220	500	5	
				26	80	178	340	7	
				27	80	190	380	8	
				27	80	200	480	10	
				33	88	260	500	9	2
				40	88	240	520	12	
				36	88	220	500	15	
				40	88	240	520	16	
				40	88	240	520	20	
				36	80	220	500	25	
				40	88	240	520	32	
				36	80	220	500	40	
				27	80	190	380	64	
				27	80	200	480	100	

输入转速	Input speeds			PLFE055	PLFE064	PLFE090	PLFE110	i ⁽¹⁾	p ⁽²⁾					
T _{2N} 和 S1 时的平均热输入转速 ⁽⁴⁾⁽⁵⁾	Average thermal input speed at T _{2N} and S1 ⁽⁴⁾⁽⁵⁾	n _{1N}	min ⁻¹	5000	3950 ⁽⁶⁾	2800 ⁽⁶⁾	2350 ⁽⁶⁾	3	1					
				5000	4500 ⁽⁶⁾	3000 ⁽⁶⁾	2550 ⁽⁶⁾	4						
				5000	4500 ⁽⁶⁾	3550 ⁽⁶⁾	2700 ⁽⁶⁾	5						
				5000	4500	4000	3500 ⁽⁶⁾	7						
				5000	4500	4000	3500 ⁽⁶⁾	8						
				5000	4500	4000	3500	10						
				5000	4500 ⁽⁶⁾	4000 ⁽⁶⁾	2850 ⁽⁶⁾	9	2					
				5000	4500	4000 ⁽⁶⁾	3100 ⁽⁶⁾	12						
				5000	4500	4000	3500 ⁽⁶⁾	15						
				5000	4500	4000	3500 ⁽⁶⁾	16						
				5000	4500	4000	3500 ⁽⁶⁾	20						
				5000	4500	4000	3500	25						
				5000	4500	4000	3500	32						
				5000	4500	4000	3500	40						
				5000	4500	4000	3500	64						
				5000	4500	4000	3500	100						
				最高机械输入转速 ⁽⁴⁾	Max. mechanical input speed ⁽⁴⁾	n _{1Limit}	min ⁻¹	18000		13000	7000	6500		

⁽¹⁾ 传动比 (i=n₁/n₂)

⁽²⁾ 减速级数

⁽³⁾ 允许 1000 次

⁽⁴⁾ 利用 NCP 针对应用设计转速 – www.neugart.com

⁽⁵⁾ 定义请参见第 166 页

⁽⁶⁾ 在 50% T_{2N} 输出和 S1 模式下的平均热输入转速

⁽¹⁾ Ratios (i=n₁/n₂)

⁽²⁾ Number of stages

⁽³⁾ Permitted 1000 times

⁽⁴⁾ Application-specific speed configurations with NCP – www.neugart.com

⁽⁵⁾ See page 167 for the definition

⁽⁶⁾ Average thermal input speed at 50% T_{2N} and S1

PLFE055
PLFE064
PLFE090

PLFE110

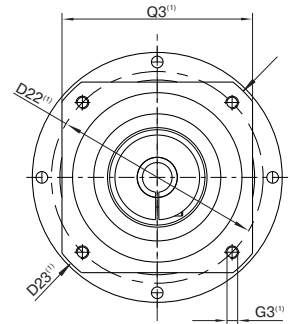
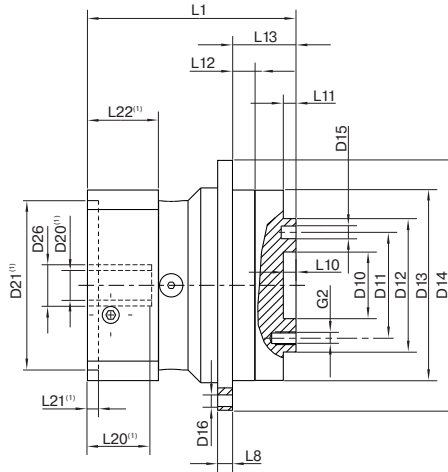
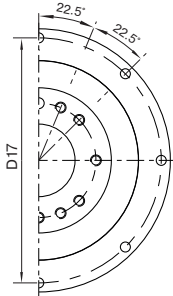
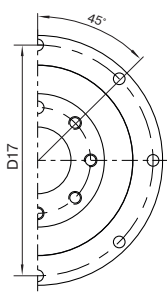

图示为带平键的 PLFE090 / 1 级 / 带有配合销孔的法兰输出轴 / 19 mm 锁紧系统 / 适配电机法兰 - 单一法兰 / B5 电机法兰类型

Drawing corresponds to a PLFE090 / 1-stage / flange output shaft with dowel hole / 19 mm clamping system / motor adaptation – one part / B5 flange type motor

(1) 具体尺寸视电机/减速机法兰而定。可以在 www.neugart.com 下 Tec Data Finder 中针对每个电机适配电机特有的输入法兰几何尺寸。

(1) The dimensions vary with the motor/gearbox flange. The input flange dimensions can be retrieved for each specific motor in Tec Data Finder at www.neugart.com

几何尺寸 ⁽²⁾	Geometry ⁽²⁾			PLFE055	PLFE064	PLFE090	PLFE110	p ⁽³⁾	Code
输出端定位凹槽直径	Centering diameter output shaft	D10	H7	16	20	31,5	40		
输出端安装孔节圆直径	Pitch circle diameter output shaft	D11		25	31,5	50	63		
法兰输出轴的直径	Flange output shaft diameter	D12	h7	34	40	63	80		
输出法兰定位凸台直径	Centering diameter output flange	D13		55	64	90	110		
输出法兰直径	Flange diameter output	D14		72	86	118	145		
输出端安装孔直径	Mounting bore output	D16		3,4 8x45°	4,5 8x45°	5,5 8x45°	5,5 8x45°		
输出法兰安装孔节圆直径	Pitch circle diameter output flange	D17		67	79	109	135		
最小总长	Min. total length	L1		71,5	69	98,5	125,5	1	
				84,5	81,5	116	152,5	2	
输出端法兰厚度	Flange thickness output	L8		4	4	7	8		
输出轴定位凸台深度	Centering depth output shaft	L10		6	4	6	6		
		L11		3	3	6	6		
输出法兰定位凸台深度	Centering depth output flange	L12		8	7,5	10,5	10,5		
输出法兰长度	Output flange length	L13		19	19,5	30	29		
电机轴直径 j6/k6	Motor shaft diameter j6/k6	D20		更多信息见第 163/164 页 More information on page 163/164					
输入端锁紧系统直径	Clamping system diameter input	D26							
带有配合销孔的法兰输出轴 (ISO 9409-1)	Flange output shaft with dowel hole (ISO 9409-1)								E
配合销孔 x 深度	Dowel hole x depth	D15	H7	4x5	5x6	6x7	6x7		
数量 x 螺纹 x 深度	Number x thread x depth	G2		7 x M4x6	7 x M5x7	7 x M6x10	11 x M6x12		

(2) 所有的尺寸单位为mm

(3) 减速机级数

(2) Dimensions in mm

(3) Number of stages

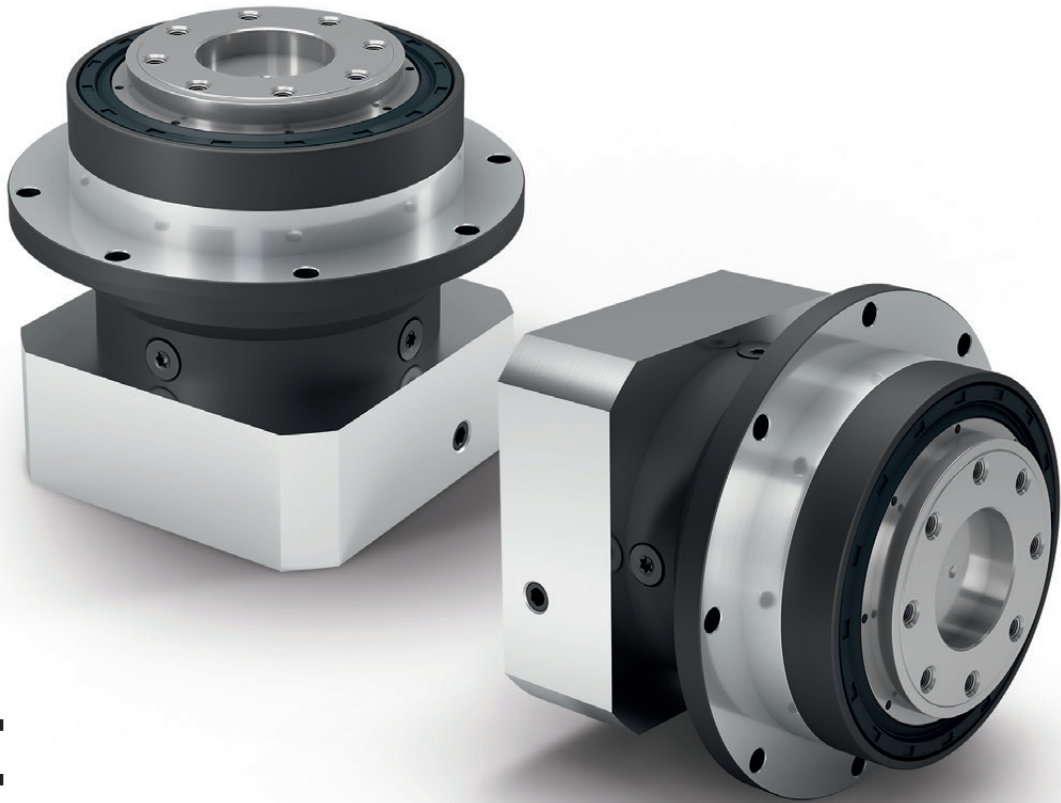

PFHE

用于高负载的法兰输出轴式行星减速机

PFHE是一种极具吸引力的产品，适用于高径向负载应用。这种特殊的、预胀紧的角接触滚子轴承，搭配符合 ISO 9409-1 标准的法兰输出轴，使得 **PFHE** 的承载能力极高。借助径向轴密封，这种减速机的输出端的防护等级达到 IP65，因此能够胜任严苛的使用环境。

The planetary gearbox with flange output shaft for high-load applications

The **PFHE** represents an economically attractive alternative for high-load applications in which high radial loads occur. The combination of special pre-stressed inclined roller bearings and a flanged output shaft in accordance with ISO 9409-1 gives the **PFHE** a very high load capacity. Thanks to the radial shaft seal that is used, this gearbox achieves protection class IP65 at the output side and can therefore also withstand adverse usage conditions.

额定扭矩
Nominal output torque **15 - 260 Nm**

径向力
Radial force **2300 - 5150 N**

轴向力
Axial force **2850 - 6450 N**

回程间隙
Torsional backlash **7 - 12 arcmin**

防护等级
Protection class **IP65**

结构尺寸
Frame sizes

64

90

110

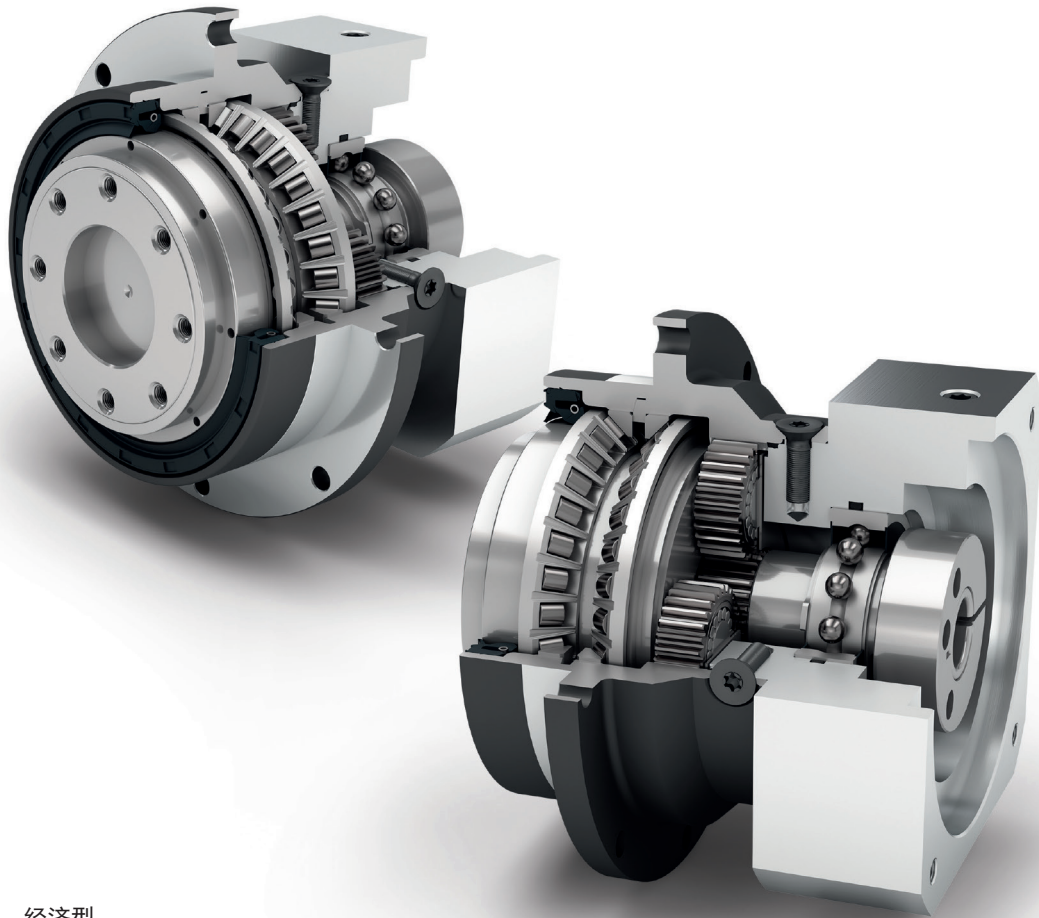

经济型
Economy Line

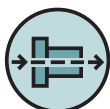

同轴减速机
Coaxial gearbox



直齿
Spur gear



配有预紧的角接触滚子轴承
Preloaded angular contact roller bearings



法兰输出轴 (按 ISO 9409-1 标准)
Flange output shaft (ISO 9409-1)



可选: 装有小齿轮的高精度减速机
132页
Option: Planetary gearbox with
mounted pinion on page 132



旋转方向 同方向
Equidirectional rotation



圆形特大号输出法兰
Extra large round type output flange



径向轴密封
Rotary shaft seal



行星齿轮架
Planet carrier in disc design



可选: 喷漆表面
——RAL 9005 黑色
Option: Painted surface
- RAL 9005 Jet black

技术特点的详细解释, 请从第173页读起。
Detailed explanations of the technical features starting on page 173.

Code	减速机参数	Gearbox characteristics			PFHE064	PFHE090	PFHE110	p ⁽¹⁾
	使用寿命 (L _{10h})	Service life (L _{10h})	t _L	h	30.000			
	满载时效率 ⁽²⁾	Efficiency at full load ⁽²⁾	η	%	97			
	最低工作温度	Min. operating temperature	T _{min}	°C	-25			
	最高工作温度	Max. operating temperature	T _{max}		90			
	防护等级	Protection class			IP65			
S	标准润滑	Standard lubrication			润滑脂(终生润滑) / Grease (lifetime lubrication)			
F	食品级润滑	Food grade lubrication			润滑脂(终生润滑) / Grease (lifetime lubrication)			
L	低温润滑 ⁽³⁾	Low temperature lubrication ⁽³⁾			润滑脂(终生润滑) / Grease (lifetime lubrication)			
	安装位置	Installation position			任意 / Any			
S	标准回程间隙	Standard backlash	j _t	arcmin	< 10	< 7	< 7	1
					< 12	< 9	< 9	2
	抗扭刚度 ⁽²⁾	Torsional stiffness ⁽²⁾	c _G	Nm / arcmin	5,4 - 10,6	16,1 - 32,5	37,0 - 77,0	1
					5,0 - 11,5	15,7 - 38,5	30,0 - 95,0	2
	减速机重量 ⁽²⁾	Gearbox weight ⁽²⁾	m _G	kg	1,1	3,1	5,9 - 6,1	1
					1,3 - 1,4	3,5 - 3,8	7,6 - 8,1	2
S	标准的箱体表面	Standard surface			箱体: 钢 - 热处理后氧化 (黑色) Housing: Steel - heat-treated and post-oxidized (black)			
B	喷漆表面	Painted surface			RAL 9005 黑色 RAL 9005 Jet black			
	运行噪音 ⁽⁴⁾	Running noise ⁽⁴⁾	Q _G	dB(A)	60	62	65	
	基于减速机输入法兰的最大弯矩 ⁽⁵⁾	Max. bending moment based on the gearbox input flange ⁽⁵⁾	M _b	Nm	8	16	40	

输出轴载荷	Output shaft loads				PFHE064	PFHE090	PFHE110	p ⁽¹⁾
20.000 h 径向力 ⁽⁶⁾⁽⁷⁾	Radial force for 20,000 h ⁽⁶⁾⁽⁷⁾	F _{r,20.000 h}	N		2300	4100	5150	
20.000 h 轴向力 ⁽⁶⁾⁽⁷⁾	Axial force for 20,000 h ⁽⁶⁾⁽⁷⁾	F _{a,20.000 h}		2850	5450	6450		
30.000 h 径向力 ⁽⁶⁾⁽⁷⁾	Radial force for 30,000 h ⁽⁶⁾⁽⁷⁾	F _{r,30.000 h}		2000	3650	4550		
30.000 h 轴向力 ⁽⁶⁾⁽⁷⁾	Axial force for 30,000 h ⁽⁶⁾⁽⁷⁾	F _{a,30.000 h}		2500	4800	5600		
最大径向力 ⁽⁷⁾⁽⁸⁾	Maximum radial force ⁽⁷⁾⁽⁸⁾	F _{r,Stat}		2300	4100	5150		
最大轴向力 ⁽⁷⁾⁽⁸⁾	Maximum axial force ⁽⁷⁾⁽⁸⁾	F _{a,Stat}		2850	5450	6450		
20.000 h 倾斜力矩 ⁽⁶⁾⁽⁸⁾	Tilting moment for 20,000 h ⁽⁶⁾⁽⁸⁾	M _{K,20.000 h}	Nm		110	278	407	
30.000 h 倾斜力矩 ⁽⁶⁾⁽⁸⁾	Tilting moment for 30,000 h ⁽⁶⁾⁽⁸⁾	M _{K,30.000 h}		96	248	360		

转动惯量	Moment of inertia				PFHE064	PFHE090	PFHE110	p ⁽¹⁾
转动惯量 ⁽²⁾	Mass moment of inertia ⁽²⁾	J	kgcm ²		0,073 - 0,224	0,407 - 1,170	1,505 - 3,658	1
					0,064 - 0,132	0,356 - 0,667	1,377 - 2,432	2

(1) 减速机级数

(2) 传动比相关的数值可在 Tec Data Finder 中检索 - www.neugart.com

(3) T_{min} = -40°C. 理想运行温度最高为 50°C

(4) 距离减速机 1 m 时: 在输入转速为 n₁=3000 min⁻¹ 且无负荷时测得; i=5

(5) 最大电机重量* (单位: kg) = 0.2 × M_b / 电机长度 (单位: m)

* 电机重量对称分布

* 水平和固定的安装位置

(6) 数据以 n₂=100 min⁻¹ 的输出轴转速为准。

(7) 以输出轴中心为准

(8) 更改 T_{2N}, F_r, F_a 以及周期和轴承使用寿命时, 数值存在偏差 (部分较高)。利用 NCP 针对应用进行专门设计 - www.neugart.com

(1) Number of stages

(2) The ratio-dependent values can be retrieved in Tec Data Finder - www.neugart.com

(3) T_{min} = -40°C. Optimal operating temperature max. 50°C

(4) Sound pressure level from 1 m, measured on input running at n₁=3000 rpm no load; i=5

(5) Max. motor weight* in kg = 0.2 × M_b / motor length in m

* with symmetrically distributed motor weight

* with horizontal and stationary mounting

(6) These values are based on an output shaft speed of n₂=100 rpm

(7) Based on the end of the output shaft

(8) Other (sometimes higher) values following changes to T_{2N}, F_r, F_a, cycle, and service life of bearing. Application specific configuration with NCP - www.neugart.com

输出扭矩	Output torques			PFHE064	PFHE090	PFHE110	$i^{(1)}$	$p^{(2)}$
额定输出扭矩 ⁽³⁾	Nominal output torque ⁽³⁾	T_{2N}	Nm	28	85	115	3	1
				38	115	155	4	
				40	110	195	5	
				25	65	135	7	
				18	50	120	8	
				15	38	95	10	
				44	130	210	9	2
				44	120	260	12	
				44	110	230	15	
				44	120	260	16	
				44	120	260	20	
				40	110	230	25	
				44	120	260	32	
				40	110	230	40	
				18	50	120	64	
				15	38	95	100	
最大输出扭矩 ⁽⁴⁾	Max. output torque ⁽⁴⁾	T_{2max}	Nm	45	136	184	3	1
				61	184	248	4	
				64	176	312	5	
				40	104	216	7	
				29	80	192	8	
				24	61	152	10	
				70	208	336	9	2
				70	192	416	12	
				70	176	368	15	
				70	192	416	16	
				70	192	416	20	
				64	176	368	25	
				70	192	416	32	
				64	176	368	40	
29	80	192	64					
24	61	152	100					

PFHE

⁽¹⁾ 传动比 ($i=n_1/n_2$)

⁽²⁾ 减速机级数

⁽³⁾ 利用 NCP 针对应用进行专门设计 – www.neugart.com

⁽⁴⁾ 允许输出轴转动30.000转; 参见第 166 页

⁽¹⁾ Ratios ($i=n_1/n_2$)

⁽²⁾ Number of stages

⁽³⁾ Application specific configuration with NCP – www.neugart.com

⁽⁴⁾ 30,000 rotations of the output shaft permitted; see page 167

输出扭矩	Output torques			PFHE064	PFHE090	PFHE110	$i^{(1)}$	$p^{(2)}$
急停扭矩 ⁽³⁾	Emergency stop torque ⁽³⁾	T_{2Stop}	Nm	66	180	390	3	1
				88	240	520	4	
				80	220	500	5	
				80	178	340	7	
				80	190	380	8	
				80	200	480	10	
				88	260	500	9	2
				88	240	520	12	
				88	220	500	15	
				88	240	520	16	
				88	240	520	20	
				80	220	500	25	
				88	240	520	32	
				80	220	500	40	
				80	190	380	64	
				80	200	480	100	

输入转速	Input speeds			PFHE064	PFHE090	PFHE110	$i^{(1)}$	$p^{(2)}$					
T_{2N} 和 S1 时的平均热输入转速 ⁽⁴⁾⁽⁵⁾	Average thermal input speed at T_{2N} and S1 ⁽⁴⁾⁽⁵⁾	n_{1N}	min^{-1}	2350 ⁽⁶⁾	1900 ⁽⁶⁾	1600 ⁽⁶⁾	3	1					
				2950 ⁽⁶⁾	2200 ⁽⁶⁾	1900 ⁽⁶⁾	4						
				3550 ⁽⁶⁾	2750 ⁽⁶⁾	2200 ⁽⁶⁾	5						
				4500	4000 ⁽⁶⁾	3350 ⁽⁶⁾	7						
				4500	4000	3500 ⁽⁶⁾	8						
				4500	4000	3500	10						
				4500	4000 ⁽⁶⁾	3300 ⁽⁶⁾	9	2					
				4500	4000	3500 ⁽⁶⁾	12						
				4500	4000	3500	15						
				4500	4000	3500	16						
				4500	4000	3500	20						
				4500	4000	3500	25						
				4500	4000	3500	32						
				4500	4000	3500	40						
				4500	4000	3500	64						
				4500	4000	3500	100						
				最高机械输入转速 ⁽⁴⁾	Max. mechanical input speed ⁽⁴⁾	n_{1Limit}	min^{-1}		7500	7000	6500		

⁽¹⁾ 传动比 ($i=n_1/n_2$)

⁽²⁾ 减速机级数

⁽³⁾ 允许 1000 次

⁽⁴⁾ 利用 NCP 针对应用设计转速 – www.neugart.com

⁽⁵⁾ 定义请参见第 166 页

⁽⁶⁾ 在 50% T_{2N} 输出和 S1 模式下的平均热输入转速

⁽¹⁾ Ratios ($i=n_1/n_2$)

⁽²⁾ Number of stages

⁽³⁾ Permitted 1000 times

⁽⁴⁾ Application-specific speed configurations with NCP – www.neugart.com

⁽⁵⁾ See page 167 for the definition

⁽⁶⁾ Average thermal input speed at 50% T_{2N} and S1

PFHE064
PFHE090

PFHE110

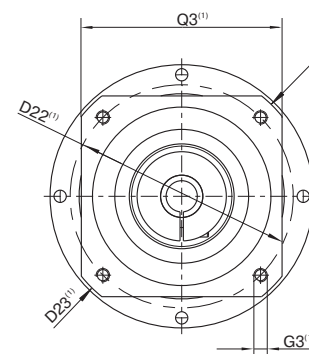
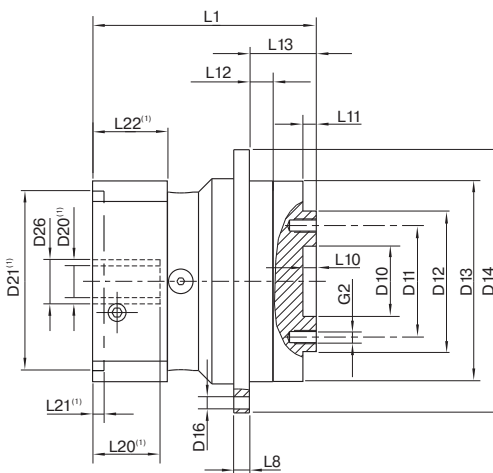
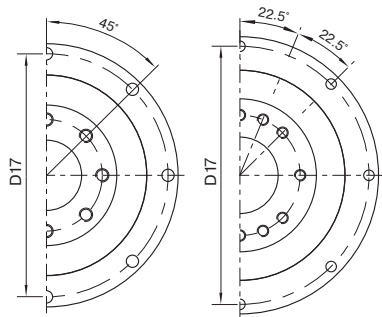

图示为带平键的 PFHE090 / 1 级 / 法兰输出轴 / 19 mm 锁紧系统 / 适配电机法兰 - 单一法兰 / B5 电机法兰类型
Drawing corresponds to a PFHE090 / 1-stage / flange output shaft / 19 mm clamping system / motor adaptation – one part / B5 flange type motor

(1) 具体尺寸视电机/减速机法兰而定。可以在 www.neugart.com 下 Tec Data Finder 中针对每个电机适配电机特有的输入法兰几何尺寸。
(1) The dimensions vary with the motor/gearbox flange. The input flange dimensions can be retrieved for each specific motor in Tec Data Finder at www.neugart.com

几何尺寸 ⁽²⁾	Geometry ⁽²⁾			PFHE064	PFHE090	PFHE110	p ⁽³⁾	Code
输出端定位凹槽直径	Centering diameter output shaft	D10	H7	20	31,5	40		
输出端安装孔节圆直径	Pitch circle diameter output shaft	D11		31,5	50	63		
法兰输出轴的直径	Flange output shaft diameter	D12	h7	40	63	80		
输出法兰定位凸台直径	Centering diameter output flange	D13		64	90	110		
输出法兰直径	Flange diameter output	D14		86	118	145		
输出端安装孔直径	Mounting bore output	D16		4,5 8x45°	5,5 8x45°	5,5 8x45°		
输出法兰安装孔节圆直径	Pitch circle diameter output flange	D17		79	109	135		
最小总长	Min. total length	L1		72	100,5	117	1	
				84,5	118	144	2	
输出端法兰厚度	Flange thickness output	L8		4	7	8		
输出轴定位凸台深度	Centering depth output shaft	L10		4	6	6		
		L11		3	6	7		
输出法兰定位凸台深度	Centering depth output flange	L12		7,5	10,5	10,5		
输出法兰长度	Output flange length	L13		19,5	30	29		
电机轴直径j6/k6	Motor shaft diameter j6/k6	D20		更多信息见第 163/164 页 More information on page 163/164				
输入端锁紧系统直径	Clamping system diameter input	D26						
法兰输出轴 (相似的 ISO 9409-1)	Flange output shaft (similar ISO 9409-1)							D
数量 x 螺纹 x 深度	Number x thread x depth	G2		8 x M5x7	8 x M6x10	12 x M6x12		

(2) 所有的尺寸单位为mm
(3) 减速机级数

(2) Dimensions in mm
(3) Number of stages

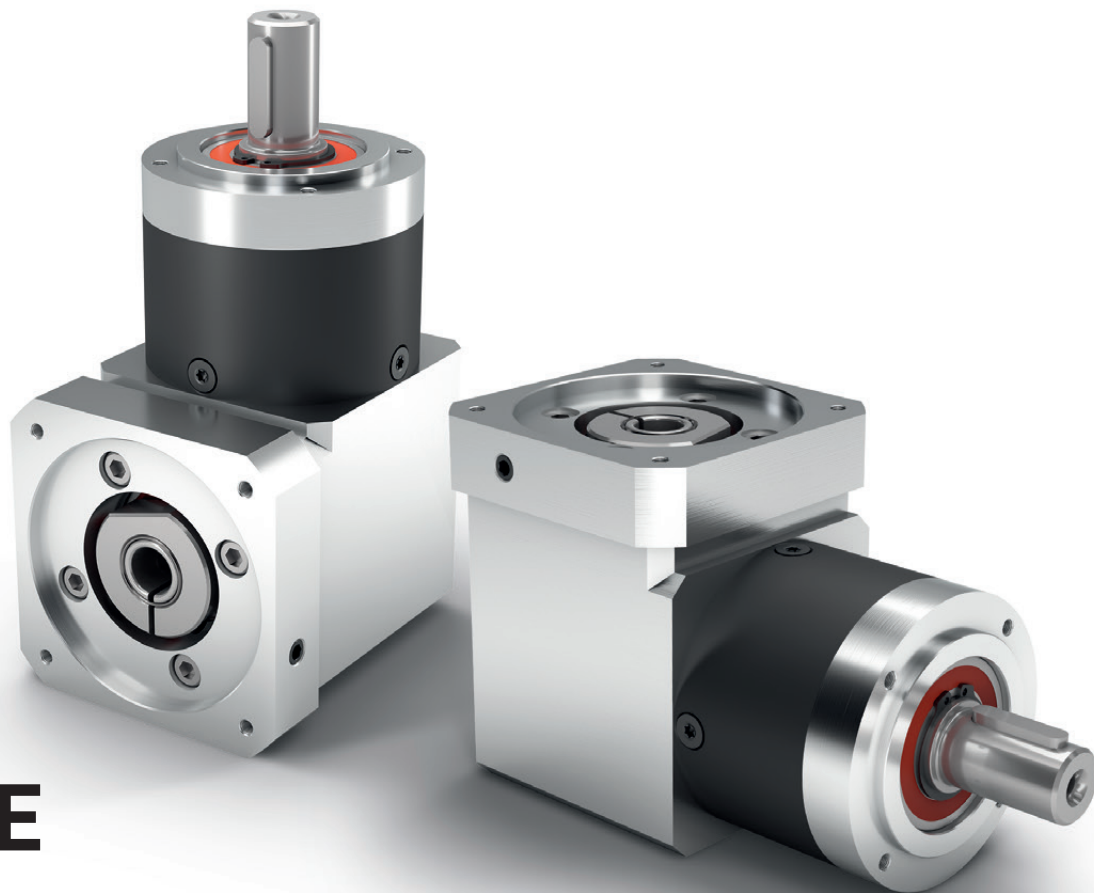

WPLE

直角行星减速机 轻巧 经济性较高

WPLE 一如既往地延续了经济型产品系列的优势。它的结构紧凑且牢固，因此非常适合动态的多轴系统。我们的直角行星减速机终身润滑，容易安装，因此其性价比是无可匹敌的。

The versatile right angle planetary gearbox with lower weight and appealing cost effectiveness

The **WPLE** consistently continues the advantages of the Economy series. With its compact but powerful design, it is perfectly suited for dynamic multi-axis systems. Our right-angle gearbox is lubricated for life, easy to mount and offers an unmatched price/performance ratio.

额定扭矩
Nominal output torque **5 - 260 Nm**

径向力
Radial force **200 - 1750 N**

轴向力
Axial force **200 - 2500 N**

回程间隙
Torsional backlash **11 - 28 arcmin**

防护等级
Protection class **IP54**

结构尺寸
Frame sizes



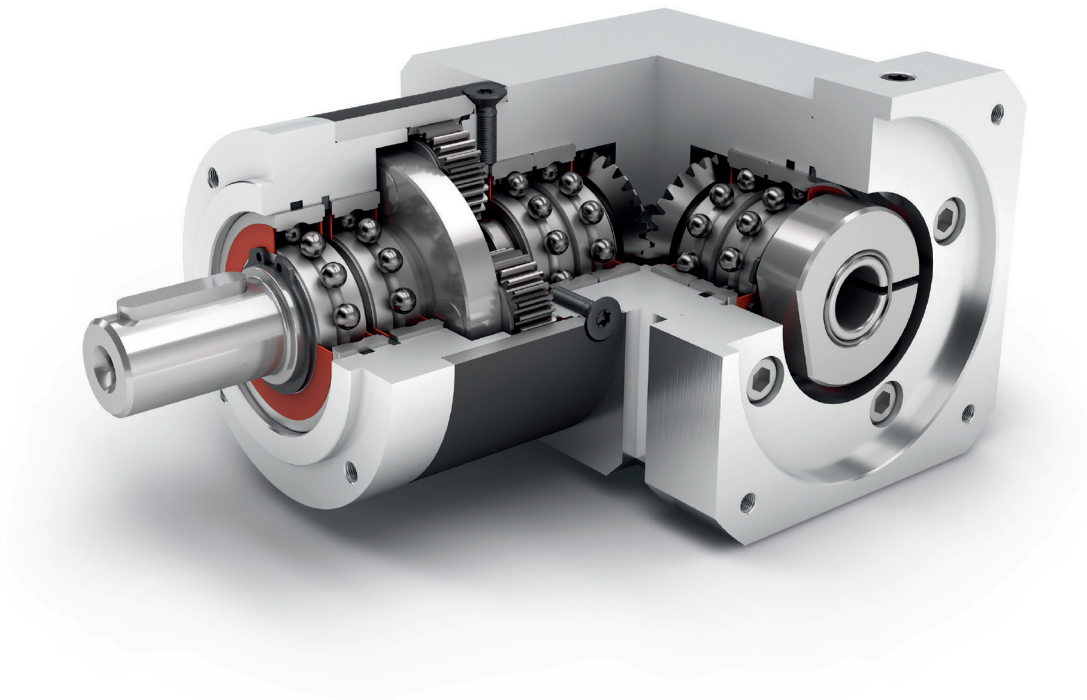

经济型
Economy Line



旋转方向 同方向
Equidirectional rotation



锥齿轮 直角型
Bevel gear right angle stage



低摩擦深沟球轴承
Low-friction deep groove ball bearings



行星齿轮架
Planet carrier in disc design



直角型减速机
Right angle gearbox



直齿
Spur gear

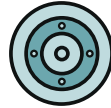

圆形输出法兰
Round type output flange



多样的传动比 (i=3 至 i=512)
High ratio variety i=3 up to i=512



可选: 喷漆表面
——RAL 9005 黑色
Option: Painted surface
- RAL 9005 Jet black

技术特点的详细解释, 请从第173页读起。
Detailed explanations of the technical features starting on page 173.

Code	减速机参数	Gearbox characteristics			WPLE040	WPLE060	WPLE080	WPLE120	p ⁽¹⁾	
	使用寿命 (L _{10h})	Service life (L _{10h})	t _L	h	20.000					
	T _{2N} × 0,88 时的使用寿命	Service life at T _{2N} × 0,88			30.000					
	满载时效率 ⁽²⁾	Efficiency at full load ⁽²⁾	η	%	95				1	
					94				2	
					88				3	
	最低工作温度	Min. operating temperature	T _{min}	°C	-25					
	最高工作温度	Max. operating temperature	T _{max}		90					
	防护等级	Protection class	IP54							
S	标准润滑	Standard lubrication	润滑脂(终生润滑) / Grease (lifetime lubrication)							
F	食品级润滑	Food grade lubrication	润滑脂(终生润滑) / Grease (lifetime lubrication)							
L	低温润滑 ⁽³⁾	Low temperature lubrication ⁽³⁾	润滑脂(终生润滑) / Grease (lifetime lubrication)							
	安装位置	Installation position	任意 / Any							
S	标准回程间隙	Standard backlash	j _t	arcmin	< 21	< 16	< 13	< 11	1	
					< 25	< 18	< 15	< 13	2	
					< 28	< 21	< 17	< 15	3	
	抗扭刚度 ⁽²⁾	Torsional stiffness ⁽²⁾	c _g	Nm / arcmin	0,5 - 0,8	1,5 - 2,3	4,0 - 7,9	9,9 - 17,5	1	
					0,7 - 1,0	2,3 - 2,8	7,2 - 10,3	17,5 - 22,0	2	
					0,8 - 1,0	2,3 - 2,8	7,9 - 10,4	17,5 - 22,0	3	
	减速机重量 ⁽²⁾	Gearbox weight ⁽²⁾	m _G	kg	0,6	1,6	3,7	9,6 - 9,7	1	
					0,6 - 0,7	1,8	4,1 - 4,2	11,3 - 11,5	2	
					0,7	2,0	4,6 - 4,7	13,1 - 13,3	3	
S	标准的箱体表面	Standard surface	箱体: 钢 - 热处理后氧化 (黑色) Housing: Steel - heat-treated and post-oxidized (black)							
B	喷漆表面	Painted surface	RAL 9005 黑色 RAL 9005 Jet black							
	运行噪音 ⁽⁴⁾	Running noise ⁽⁴⁾	Q _g	dB(A)	68	70	73	75		
	基于减速机输入法兰的最大弯矩 ⁽⁵⁾	Max. bending moment based on the gearbox input flange ⁽⁵⁾	M _b	Nm	2	5	10,5	26		

输出轴载荷	Output shaft loads			WPLE040	WPLE060	WPLE080	WPLE120	p ⁽¹⁾
20.000 h 径向力 ⁽⁶⁾⁽⁷⁾	Radial force for 20,000 h ⁽⁶⁾⁽⁷⁾	F _{r20.000h}	N	200	400	750	1750	
20.000 h 轴向力 ⁽⁶⁾⁽⁷⁾	Axial force for 20,000 h ⁽⁶⁾⁽⁷⁾	F _{a20.000h}		200	500	1000	2500	
30.000 h 径向力 ⁽⁶⁾⁽⁷⁾	Radial force for 30,000 h ⁽⁶⁾⁽⁷⁾	F _{r30.000h}		160	340	650	1500	
30.000 h 轴向力 ⁽⁶⁾⁽⁷⁾	Axial force for 30,000 h ⁽⁶⁾⁽⁷⁾	F _{a30.000h}		160	450	900	2100	
最大径向力 ⁽⁷⁾⁽⁸⁾	Maximum radial force ⁽⁷⁾⁽⁸⁾	F _{r Stat}		200	700	1250	2000	
最大轴向力 ⁽⁷⁾⁽⁸⁾	Maximum axial force ⁽⁷⁾⁽⁸⁾	F _{a Stat}		240	800	1600	3800	
20.000 h 倾斜力矩 ⁽⁶⁾⁽⁸⁾	Tilting moment for 20,000 h ⁽⁶⁾⁽⁸⁾	M _{K20.000h}	Nm	6	14	31	101	
30.000 h 倾斜力矩 ⁽⁶⁾⁽⁸⁾	Tilting moment for 30,000 h ⁽⁶⁾⁽⁸⁾	M _{K30.000h}		4	12	27	86	

转动惯量	Moment of inertia			WPLE040	WPLE060	WPLE080	WPLE120	p ⁽¹⁾
转动惯量 ⁽²⁾	Mass moment of inertia ⁽²⁾	J	kgcm ²	0,032 - 0,049	0,209 - 0,346	0,862 - 1,226	2,645 - 3,670	1
				0,032 - 0,048	0,210 - 0,338	0,868 - 1,184	2,679 - 3,597	2
				0,032 - 0,047	0,210 - 0,220	0,868 - 1,162	2,679 - 3,506	3

(1) 减速机级数
 (2) 传动比相关的数值可在 Tec Data Finder 中检索 - www.neugart.com
 (3) T_{min} = -40°C. 理想运行温度最高为 50°C
 (4) 距离减速机 1 m 时: 在输入转速为 n₁=3000 min⁻¹ 且无负荷时测得: i=5
 (5) 最大电机重量* (单位: kg) = 0.2 × M_b / 电机长度 (单位: m)
 * 电机重量对称分布
 * 水平和固定的安装位置
 (6) 数据以 n₂=100 min⁻¹ 的输出轴转速为准。
 (7) 以输出轴中心为准
 (8) 更改 T_{2N}, F_r, F_a 以及周期和轴承使用寿命时, 数值存在偏差 (部分较高)。利用 NCP 针对应用进行专门设计 - www.neugart.com

(1) Number of stages
 (2) The ratio-dependent values can be retrieved in Tec Data Finder - www.neugart.com
 (3) T_{min} = -40°C. Optimal operating temperature max. 50°C
 (4) Sound pressure level from 1 m, measured on input running at n₁=3000 rpm no load; i=5
 (5) Max. motor weight* in kg = 0.2 × M_b / motor length in m
 * with symmetrically distributed motor weight
 * with horizontal and stationary mounting
 (6) These values are based on an output shaft speed of n₂=100 rpm
 (7) Based on center of output shaft
 (8) Other (sometimes higher) values following changes to T_{2N}, F_r, F_a, cycle, and service life of bearing. Application specific configuration with NCP - www.neugart.com

输出扭矩	Output torques			WPLE040	WPLE060	WPLE080	WPLE120	i ⁽¹⁾	p ⁽²⁾
额定输出扭矩 ⁽³⁾⁽⁴⁾	Nominal output torque ⁽³⁾⁽⁴⁾	T _{2N}	Nm	4,5	14	40 ⁽⁵⁾	80 ⁽⁵⁾	3	1
				6	19	53 ⁽⁵⁾	105 ⁽⁵⁾	4	
				7,5	24	67 ⁽⁵⁾	130 ⁽⁵⁾	5	
				8,5	25	65	135	7	
				6	18	50	120	8	
				5	15	38	95	10	
				16,5 ⁽⁵⁾	44 ⁽⁵⁾	130 ⁽⁵⁾	210 ⁽⁵⁾	9	2
				20 ⁽⁵⁾	44	120 ⁽⁵⁾	260 ⁽⁵⁾	12	
				18 ⁽⁵⁾	44	110	230	15	
				20 ⁽⁵⁾	44	120	260	16	
				20 ⁽⁵⁾	44	120	260	20	
				18	40	110	230	25	3
				20	44	120	260	32	
				18	40	110	230	40	
				7,5	18	50	120	64	
				20	44	110	260	60	
				20	44	120	260	80	
				20	44	120	260	100	
				18	44	110	230	120	
				20	44	120	260	160	
18	40	110	230	200					
20	44	120	260	256					
18	40	110	230	320					
7,5	18	50	120	512					
最大输出扭矩 ⁽⁴⁾⁽⁶⁾	Max. output torque ⁽⁴⁾⁽⁶⁾	T _{2max}	Nm	7	22	64	128	3	1
				10	30	85	168	4	
				12	38	107	208	5	
				13,5	40	104	216	7	
				10	29	80	192	8	
				8	24	61	152	10	
				26	70	208	336	9	2
				32	70	192	416	12	
				29	70	176	368	15	
				32	70	192	416	16	
				32	70	192	416	20	
				29	64	176	368	25	3
				32	70	192	416	32	
				29	64	176	368	40	
				12	29	80	192	64	
				32	70	176	416	60	
				32	70	192	416	80	
				32	70	192	416	100	
				29	70	176	368	120	
				32	70	192	416	160	
29	64	176	368	200					
32	70	192	416	256					
29	64	176	368	320					
12	29	80	192	512					

WPLE

(1) 传动比 (i=n₁/n₂)
 (2) 减速机级数
 (3) 利用 NCP 针对应用进行专门设计 - www.neugart.com
 (4) 平键 (代码 "A")时的数值: 针对交变载荷
 (5) T_{2N} 作用时 寿命不是10.000 h
 (6) 允许输出轴转动30.000转; 参见第 166 页

(1) Ratios (i=n₁/n₂)
 (2) Number of stages
 (3) Application specific configuration with NCP - www.neugart.com
 (4) Values for feather key (code "A"): for repeated load
 (5) Different service life: 10,000 h at T_{2N}
 (6) 30,000 rotations of the output shaft permitted; see page 167

输出扭矩	Output torques			WPLE040	WPLE060	WPLE080	WPLE120	i ⁽¹⁾	p ⁽²⁾
急停扭矩 ⁽³⁾	Emergency stop torque ⁽³⁾	T _{2Stop}	Nm	22,5	66	180	360	3	1
				28	86	240	474	4	
				35	80	220	500	5	
				26	80	178	340	7	
				27	80	190	380	8	
				25	70	170	430	10	
				33	88	260	500	9	2
				40	88	240	520	12	
				36	88	220	500	15	
				40	88	240	520	16	
				40	88	240	520	20	
				36	80	220	500	25	
				40	88	240	520	32	3
				36	80	220	500	40	
				27	80	190	380	64	
				40	88	220	520	60	
				40	88	240	520	80	
				40	88	240	520	100	
				36	88	220	500	120	3
				40	88	240	520	160	
36	80	220	500	200					
40	88	240	520	256					
36	80	220	500	320					
27	80	190	380	512					

输入转速	Input speeds			WPLE040	WPLE060	WPLE080	WPLE120	i ⁽¹⁾	p ⁽²⁾
T _{2N} 和 S1 时的平均热输入转速 ⁽⁴⁾⁽⁵⁾	Average thermal input speed at T _{2N} and S1 ⁽⁴⁾⁽⁵⁾	n _{1N}	min ⁻¹	5000	4500 ⁽⁶⁾	3500 ⁽⁶⁾	2850 ⁽⁶⁾	3	1
				5000	4500 ⁽⁶⁾	3550 ⁽⁶⁾	2950 ⁽⁶⁾	4	
				5000	4500 ⁽⁶⁾	3600 ⁽⁶⁾	3050 ⁽⁶⁾	5	
				5000	4500	4000 ⁽⁶⁾	3500 ⁽⁶⁾	7	
				5000	4500	4000 ⁽⁶⁾	3500 ⁽⁶⁾	8	
				5000	4500	4000	3500	10	
				5000	4500 ⁽⁶⁾	3250 ⁽⁶⁾	2950 ⁽⁶⁾	9	2
				5000	4500 ⁽⁶⁾	3850 ⁽⁶⁾	3050 ⁽⁶⁾	12	
				5000	4500	4000 ⁽⁶⁾	3500 ⁽⁶⁾	15	
				5000	4500	4000 ⁽⁶⁾	3450 ⁽⁶⁾	16	
				5000	4500	4000 ⁽⁶⁾	3500 ⁽⁶⁾	20	
				5000	4500	4000	3500 ⁽⁶⁾	25	
				5000	4500	4000	3500	32	3
				5000	4500	4000	3500	40	
				5000	4500	4000	3500	64	
				5000	4500	4000	3500	60	
				5000	4500	4000	3500	80	
				5000	4500	4000	3500	100	
				5000	4500	4000	3500	120	3
				5000	4500	4000	3500	160	
5000	4500	4000	3500	200					
5000	4500	4000	3500	256					
5000	4500	4000	3500	320					
5000	4500	4000	3500	512					
最高机械输入转速 ⁽⁴⁾	Max. mechanical input speed ⁽⁴⁾	n _{1Limit}	min ⁻¹	18000	13000	7000	6500		

⁽¹⁾ 传动比 (i=n₁/n₂)

⁽²⁾ 减速机级数

⁽³⁾ 允许 1000 次

⁽⁴⁾ 利用 NCP 针对应用设计转速 – www.neugart.com

⁽⁵⁾ 定义请参见第 166 页

⁽⁶⁾ 在 50% T_{2N} 输出和 S1 模式下 的平均热输入转速

⁽¹⁾ Ratios (i=n₁/n₂)

⁽²⁾ Number of stages

⁽³⁾ Permitted 1000 times

⁽⁴⁾ Application-specific speed configurations with NCP – www.neugart.com

⁽⁵⁾ See page 167 for the definition

⁽⁶⁾ Average thermal input speed at 50% T_{2N} and S1

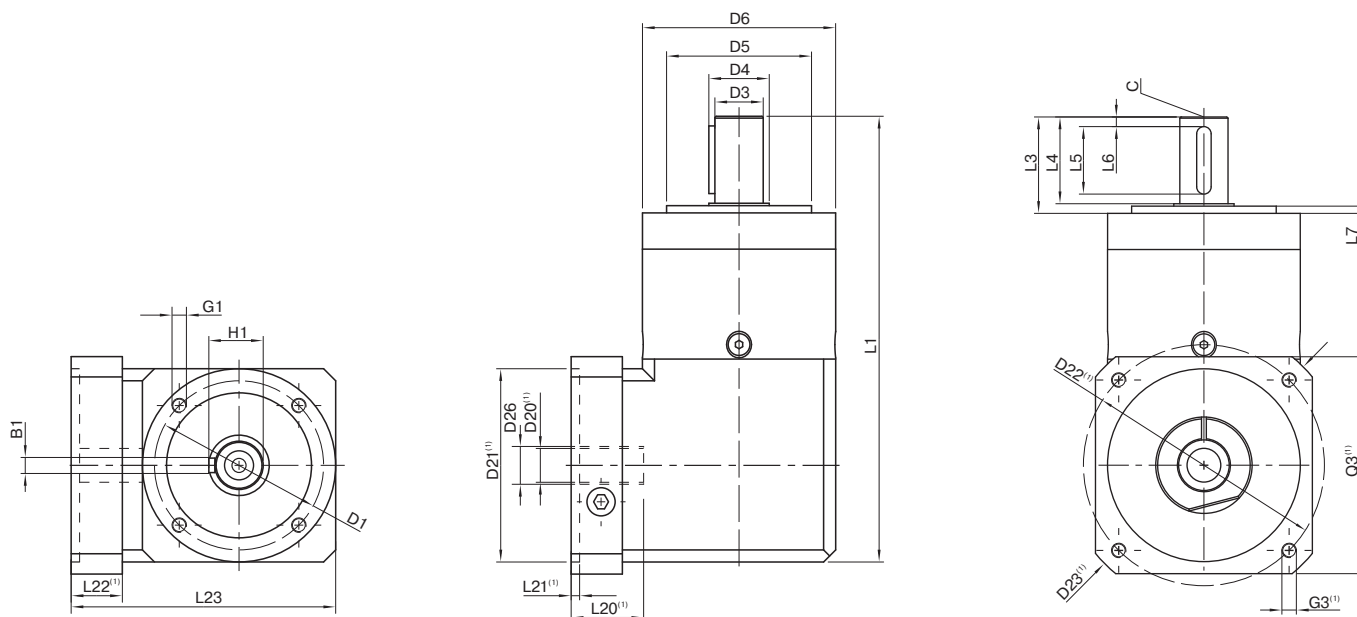

图示为带平键的 WPLE080 / 1 级 / 附带平键的输出轴 / 19 mm 锁紧系统 / 适配电机法兰 - 2 件式 - 正方形通用法兰 / B5 电机法兰类型
 Drawing corresponds to a WPLE080 / 1-stage / output shaft with feather key / 19 mm clamping system / motor adaptation - 2-part - square universal flange / B5 flange type motor

⁽¹⁾ 具体尺寸视电机/减速机法兰而定。可以在 www.neugart.com 下 Tec Data Finder 中针对每个电机适配电机特有的输入法兰几何尺寸。
⁽¹⁾ The dimensions vary with the motor/gearbox flange. The input flange dimensions can be retrieved for each specific motor in Tec Data Finder at www.neugart.com

几何尺寸 ⁽²⁾	Geometry ⁽²⁾			WPLE040	WPLE060	WPLE080	WPLE120	p ⁽³⁾	Code
输出端安装孔节圆直径	Pitch circle diameter output	D1		34	52	70	100		
输出轴直径	Shaft diameter output	D3	h7	10	14	20	25		
输出轴轴肩直径	Shaft collar output	D4		12	17	25	35		
输出端定位凸台直径	Centering diameter output	D5	h7	26	40	60	80		
箱体直径	Housing diameter	D6		40	60	80	115		
安装螺纹 x 深度	Mounting thread x depth	G1	4x	M4x6	M5x8	M6x10	M10x16		
总长	Total length	L1		110	147	184	249,5	1	
				123	159,5	201,5	277	2	
				135,5	172	219	304,5	3	
输出轴轴长	Shaft length output	L3		26	35	40	55		
输出端定位凸台深度	Centering depth output	L7		2	3	3	4		
最小总高度	Min. overall height	L23		62	85,5	109,5	145,5		
电机轴直径 j6/k6	Motor shaft diameter j6/k6	D20		更多信息见第 163/164 页 More information on page 163/164					
输入端锁紧系统直径	Clamping system diameter input	D26							
带平键的输出轴 (DIN 6885-1)	Output shaft with feather key (DIN 6885-1)			A 3x3x18	A 5x5x25	A 6x6x28	A 8x7x40		A
平键宽度 (DIN 6885-1)	Feather key width (DIN 6885-1)	B1		3	5	6	8		
含平键在内的轴高 (DIN 6885-1)	Shaft height including feather key (DIN 6885-1)	H1		11,2	16	22,5	28		
到轴肩的距离	Shaft length from shoulder	L4		23	30	36	50		
平键长度	Feather key length	L5		18	25	28	40		
到轴端的距离	Distance from shaft end	L6		2,5	2,5	4	5		
中心孔 (DIN 332, DR 形)	Center hole (DIN 332, type DR)	C		M3x9	M5x12,5	M6x16	M10x22		
光滑输出轴	Smooth output shaft								B
到轴肩的距离	Shaft length from shoulder	L4		23	30	36	50		

⁽²⁾ 所有的尺寸单位为mm
⁽³⁾ 减速机级数

⁽²⁾ Dimensions in mm
⁽³⁾ Number of stages

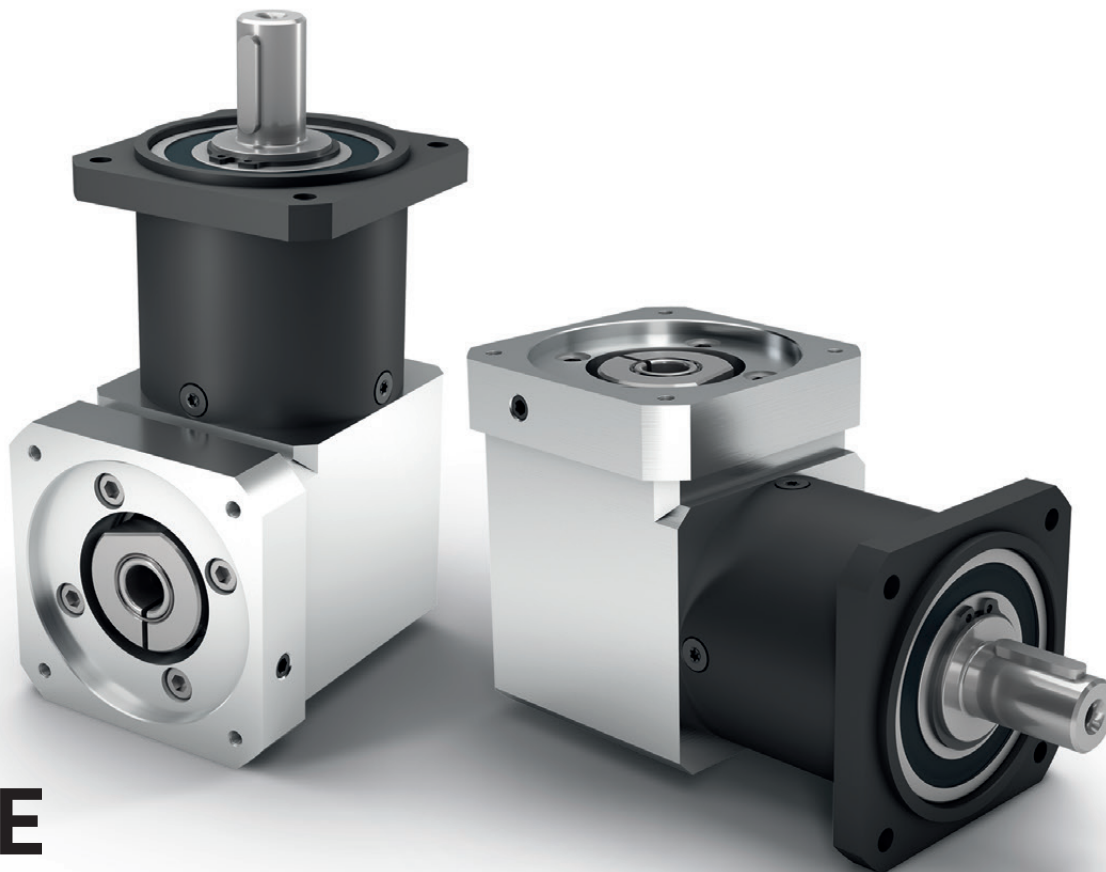

WPLQE

直角行星减速机，带方形通孔输出法兰
安装灵活，适用于承载力很大的
工况中

我们的 **WPLQE** 是带有正方形输出法兰的直角行星减速机。因此，它特别容易安装，使用方式多样，而且凭借大尺寸的深沟球轴承，可以承受较高的径向力和轴向力。

The right angle planetary gearbox
with universal output flange –
flexible installation options and
for high forces

Our **WPLQE** is the right-angle gearbox with a square output flange. This makes it particularly easy to mount, versatile and, thanks to its larger deep groove ball bearings, also suitable for higher radial and axial forces.

额定扭矩
Nominal output torque **14 - 260 Nm**

径向力
Radial force **900 - 2950 N**

轴向力
Axial force **1000 - 2500 N**

回程间隙
Torsional backlash **11 - 21 arcmin**

防护等级
Protection class **IP54**

结构尺寸
Frame sizes

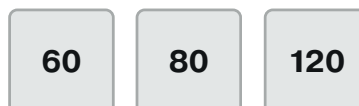

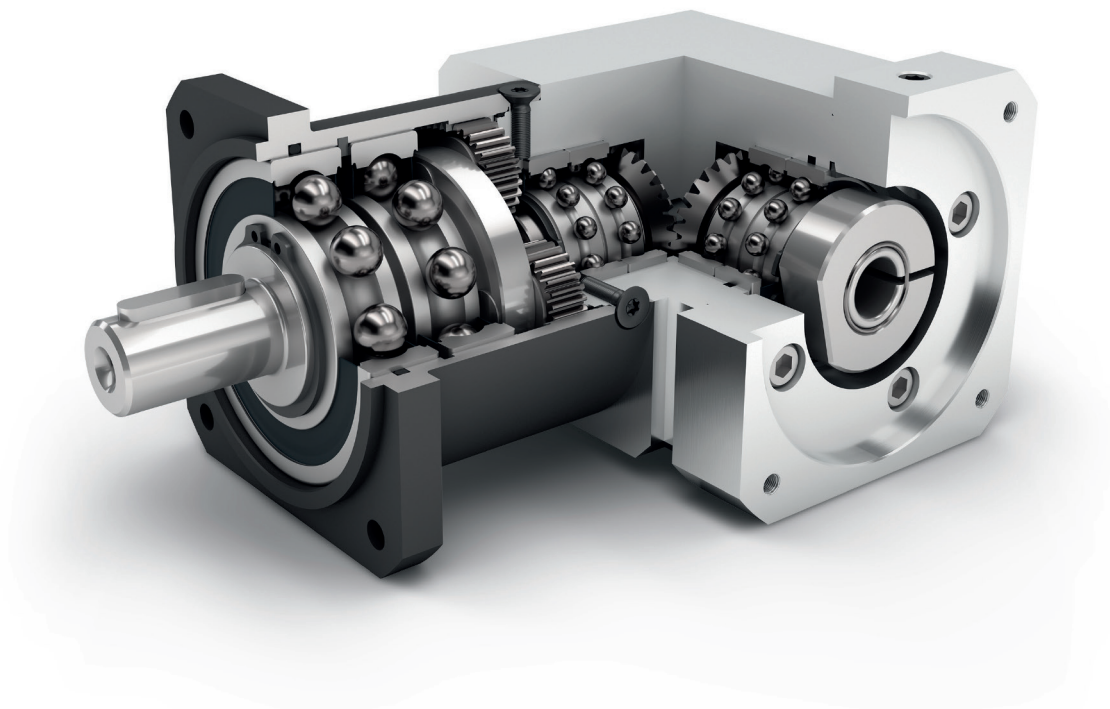

WPLQE



经济型
Economy Line



旋转方向 同方向
Equidirectional rotation



锥齿轮 直角型
Bevel gear right angle stage



增强深沟球轴承
Reinforced deep groove ball bearings



行星齿轮架
Planet carrier in disc design



直角型减速机
Right angle gearbox



直齿
Spur gear

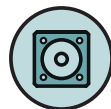

正方形输出法兰
Square type output flange



多样的传动比 (i=3 至 i=512)
High ratio variety i=3 up to i=512



可选: 喷漆表面
——RAL 9005 黑色
Option: Painted surface
- RAL 9005 Jet black

技术特点的详细解释, 请从第173页读起。
Detailed explanations of the technical features starting on page 173.

Code	减速机参数	Gearbox characteristics			WPLQE060	WPLQE080	WPLQE120	p ⁽¹⁾
	使用寿命 (L _{10h})	Service life (L _{10h})	t _L	h	20.000			
	T _{2N} × 0,88 时的使用寿命	Service life at T _{2N} × 0,88			30.000			
	满载时效率 ⁽²⁾	Efficiency at full load ⁽²⁾	η	%	95			1
					94			2
					88			3
	最低工作温度	Min. operating temperature	T _{min}	°C	-25			
	最高工作温度	Max. operating temperature	T _{max}		90			
	防护等级	Protection class				IP54		
S	标准润滑	Standard lubrication				润滑脂(终生润滑) / Grease (lifetime lubrication)		
F	食品级润滑	Food grade lubrication				润滑脂(终生润滑) / Grease (lifetime lubrication)		
L	低温润滑 ⁽³⁾	Low temperature lubrication ⁽³⁾				润滑脂(终生润滑) / Grease (lifetime lubrication)		
	安装位置	Installation position				任意 / Any		
S	标准回程间隙	Standard backlash	j _t	arcmin	< 16	< 13	< 11	1
					< 18	< 15	< 13	2
					< 21	< 17	< 15	3
	抗扭刚度 ⁽²⁾	Torsional stiffness ⁽²⁾	c _g	Nm / arcmin	1,9 - 3,1	4,4 - 9,4	9,3 - 15,3	1
					3,3 - 4,0	8,5 - 13,0	15,3 - 19,0	2
					3,3 - 4,1	9,4 - 13,3	15,6 - 19,0	3
	减速机重量 ⁽²⁾	Gearbox weight ⁽²⁾	m _G	kg	1,8	4,2 - 4,5	10,4 - 10,5	1
					1,9 - 2,0	4,9 - 5,0	12,1 - 12,3	2
					2,2	5,4 - 5,5	13,9 - 14,1	3
S	标准的箱体表面	Standard surface				箱体: 钢 - 热处理后氧化 (黑色) Housing: Steel - heat-treated and post-oxidized (black)		
B	喷漆表面	Painted surface				RAL 9005 黑色 RAL 9005 Jet black		
	运行噪音 ⁽⁴⁾	Running noise ⁽⁴⁾	Q _g	dB(A)	70	73	75	
	基于减速机输入法兰的最大弯矩 ⁽⁵⁾	Max. bending moment based on the gearbox input flange ⁽⁵⁾	M _b	Nm	5	10,5	26	

输出轴载荷	Output shaft loads			WPLQE060	WPLQE080	WPLQE120	p ⁽¹⁾
20.000 h 径向力 ⁽⁶⁾⁽⁷⁾	Radial force for 20,000 h ⁽⁶⁾⁽⁷⁾	F _{r20.000 h}	N	900	2050	2950	
20.000 h 轴向力 ⁽⁶⁾⁽⁷⁾	Axial force for 20,000 h ⁽⁶⁾⁽⁷⁾	F _{a20.000 h}		1000	2500	2500	
30.000 h 径向力 ⁽⁶⁾⁽⁷⁾	Radial force for 30,000 h ⁽⁶⁾⁽⁷⁾	F _{r30.000 h}		700	1700	2400	
30.000 h 轴向力 ⁽⁶⁾⁽⁷⁾	Axial force for 30,000 h ⁽⁶⁾⁽⁷⁾	F _{a30.000 h}		800	2000	2100	
最大径向力 ⁽⁷⁾⁽⁸⁾	Maximum radial force ⁽⁷⁾⁽⁸⁾	F _{r Stat}		1500	2500	4000	
最大轴向力 ⁽⁷⁾⁽⁸⁾	Maximum axial force ⁽⁷⁾⁽⁸⁾	F _{a Stat}		1950	3800	3800	
20.000 h 倾斜力矩 ⁽⁶⁾⁽⁸⁾	Tilting moment for 20,000 h ⁽⁶⁾⁽⁸⁾	M _{K20.000 h}	Nm	37	102	232	
30.000 h 倾斜力矩 ⁽⁶⁾⁽⁸⁾	Tilting moment for 30,000 h ⁽⁶⁾⁽⁸⁾	M _{K30.000 h}		29	84	188	

转动惯量	Moment of inertia			WPLQE060	WPLQE080	WPLQE120	p ⁽¹⁾
转动惯量 ⁽²⁾	Mass moment of inertia ⁽²⁾	J	kgcm ²	0,210 - 0,359	0,874 - 1,355	2,648 - 3,702	1
				0,210 - 0,340	0,869 - 1,196	2,679 - 3,601	2
				0,210 - 0,221	0,868 - 1,162	2,679 - 3,506	3

(1) 减速机级数
 (2) 传动比相关的数值可在 Tec Data Finder 中检索 - www.neugart.com
 (3) T_{min} = -40°C. 理想运行温度最高为 50°C
 (4) 距离减速机 1 m 时: 在输入转速为 n₁=3000 min⁻¹ 且无负荷时测得; i=5
 (5) 最大电机重量* (单位: kg) = 0.2 × M_b / 电机长度 (单位: m)
 * 电机重量对称分布
 * 水平和固定的安装位置
 (6) 数据以 n₂=100 min⁻¹ 的输出轴转速为准。
 (7) 以输出轴中心为准
 (8) 更改 T_{2N}, F_r, F_a 以及周期和轴承使用寿命时, 数值存在偏差 (部分较高)。利用 NCP 针对应用进行专门设计 - www.neugart.com

(1) Number of stages
 (2) The ratio-dependent values can be retrieved in Tec Data Finder - www.neugart.com
 (3) T_{min} = -40°C. Optimal operating temperature max. 50°C
 (4) Sound pressure level from 1 m, measured on input running at n₁=3000 rpm no load; i=5
 (5) Max. motor weight* in kg = 0.2 × M_b / motor length in m
 * with symmetrically distributed motor weight
 * with horizontal and stationary mounting
 (6) These values are based on an output shaft speed of n₂=100 rpm
 (7) Based on center of output shaft
 (8) Other (sometimes higher) values following changes to T_{2N}, F_r, F_a, cycle, and service life of bearing. Application specific configuration with NCP - www.neugart.com

输出扭矩	Output torques			WPLQE060	WPLQE080	WPLQE120	i ⁽¹⁾	p ⁽²⁾
额定输出扭矩 ⁽³⁾⁽⁴⁾	Nominal output torque ⁽³⁾⁽⁴⁾	T _{2N}	Nm	14	40 ⁽⁵⁾	80 ⁽⁵⁾	3	1
				19	53 ⁽⁵⁾	105 ⁽⁵⁾	4	
				24	67 ⁽⁵⁾	130 ⁽⁵⁾	5	
				25	65	135	7	
				18	50	120	8	
				15	38	95	10	
				44 ⁽⁵⁾	130 ⁽⁵⁾	210 ⁽⁵⁾	9	
				44	120 ⁽⁵⁾	260 ⁽⁵⁾	12	2
				44	110	230	15	
				44	120	260	16	
				44	120	260	20	
				40	110	230	25	
				44	120	260	32	
				40	110	230	40	
				18	50	120	64	3
				44	110	260	60	
				44	120	260	80	
				44	120	260	100	
				44	110	230	120	
				44	120	260	160	
				40	110	230	200	
44	120	260	256					
40	110	230	320					
18	50	120	512					
最大输出扭矩 ⁽⁴⁾⁽⁶⁾	Max. output torque ⁽⁴⁾⁽⁶⁾	T _{2max}	Nm	22	64	128	3	1
				30	85	168	4	
				38	107	208	5	
				40	104	216	7	
				29	80	192	8	
				24	61	152	10	
				70	208	336	9	
				70	192	416	12	2
				70	176	368	15	
				70	192	416	16	
				70	192	416	20	
				64	176	368	25	
				70	192	416	32	
				64	176	368	40	
				29	80	192	64	3
				70	176	416	60	
				70	192	416	80	
				70	192	416	100	
				70	176	368	120	
				70	192	416	160	
				64	176	368	200	
70	192	416	256					
64	176	368	320					
29	80	192	512					

WPLQE

(1) 传动比 (i=n₁/n₂)
 (2) 减速机级数
 (3) 利用 NCP 针对应用进行专门设计 - www.neugart.com
 (4) 平键 (代码 "A")时的数值; 针对交变载荷
 (5) T_{2N} 作用时 寿命不是10.000 h
 (6) 允许输出轴转动30.000转; 参见第 166 页

(1) Ratios (i=n₁/n₂)
 (2) Number of stages
 (3) Application specific configuration with NCP - www.neugart.com
 (4) Values for feather key (code "A"): for repeated load
 (5) Different service life: 10,000 h at T_{2N}
 (6) 30,000 rotations of the output shaft permitted; see page 167

输出扭矩	Output torques			WPLQE060	WPLQE080	WPLQE120	$i^{(1)}$	$p^{(2)}$
急停扭矩 ⁽³⁾	Emergency stop torque ⁽³⁾	T_{2Stop}	Nm	66	180	360	3	1
				86	240	474	4	
				80	220	500	5	
				80	178	340	7	
				80	190	380	8	
				70	170	430	10	
				88	260	500	9	2
				88	240	520	12	
				88	220	500	15	
				88	240	520	16	
				88	240	520	20	
				80	220	500	25	
				88	240	520	32	3
				80	220	500	40	
				80	190	380	64	
				88	220	520	60	
				88	240	520	80	
				88	240	520	100	
				88	220	500	120	
				88	240	520	160	
				80	220	500	200	
88	240	520	256					
80	220	500	320					
80	190	380	512					

输入转速	Input speeds			WPLQE060	WPLQE080	WPLQE120	$i^{(1)}$	$p^{(2)}$
T_{2N} 和 S1 时的平均热输入转速 ⁽⁴⁾⁽⁵⁾	Average thermal input speed at T_{2N} and S1 ⁽⁴⁾⁽⁵⁾	n_{1N}	min^{-1}	4500 ⁽⁶⁾	3100 ⁽⁶⁾	2850 ⁽⁶⁾	3	1
				4500 ⁽⁶⁾	3250 ⁽⁶⁾	2950 ⁽⁶⁾	4	
				4500 ⁽⁶⁾	3350 ⁽⁶⁾	3050 ⁽⁶⁾	5	
				4500	4000 ⁽⁶⁾	3500 ⁽⁶⁾	7	
				4500	4000 ⁽⁶⁾	3500 ⁽⁶⁾	8	
				4500	4000	3500	10	
				4500 ⁽⁶⁾	3150 ⁽⁶⁾	2950 ⁽⁶⁾	9	2
				4500 ⁽⁶⁾	3750 ⁽⁶⁾	3050 ⁽⁶⁾	12	
				4500	4000 ⁽⁶⁾	3500 ⁽⁶⁾	15	
				4500	4000 ⁽⁶⁾	3450 ⁽⁶⁾	16	
				4500	4000 ⁽⁶⁾	3500 ⁽⁶⁾	20	
				4500	4000	3500 ⁽⁶⁾	25	
				4500	4000	3500	32	3
				4500	4000	3500	40	
				4500	4000	3500	64	
				4500	4000	3500	60	
				4500	4000	3500	80	
				4500	4000	3500	100	
				4500	4000	3500	120	
				4500	4000	3500	160	
				4500	4000	3500	200	
4500	4000	3500	256					
4500	4000	3500	320					
4500	4000	3500	512					
最高机械输入转速 ⁽⁴⁾	Max. mechanical input speed ⁽⁴⁾	n_{1Limit}	min^{-1}	13000	7000	6500		

⁽¹⁾ 传动比 ($i=n_1/n_2$)

⁽²⁾ 减速机级数

⁽³⁾ 允许 1000 次

⁽⁴⁾ 利用 NCP 针对应用设计转速 – www.neugart.com

⁽⁵⁾ 定义请参见第 166 页

⁽⁶⁾ 在 50% T_{2N} 输出和 S1 模式下的平均热输入转速

⁽¹⁾ Ratios ($i=n_1/n_2$)

⁽²⁾ Number of stages

⁽³⁾ Permitted 1000 times

⁽⁴⁾ Application-specific speed configurations with NCP – www.neugart.com

⁽⁵⁾ See page 167 for the definition

⁽⁶⁾ Average thermal input speed at 50% T_{2N} and S1

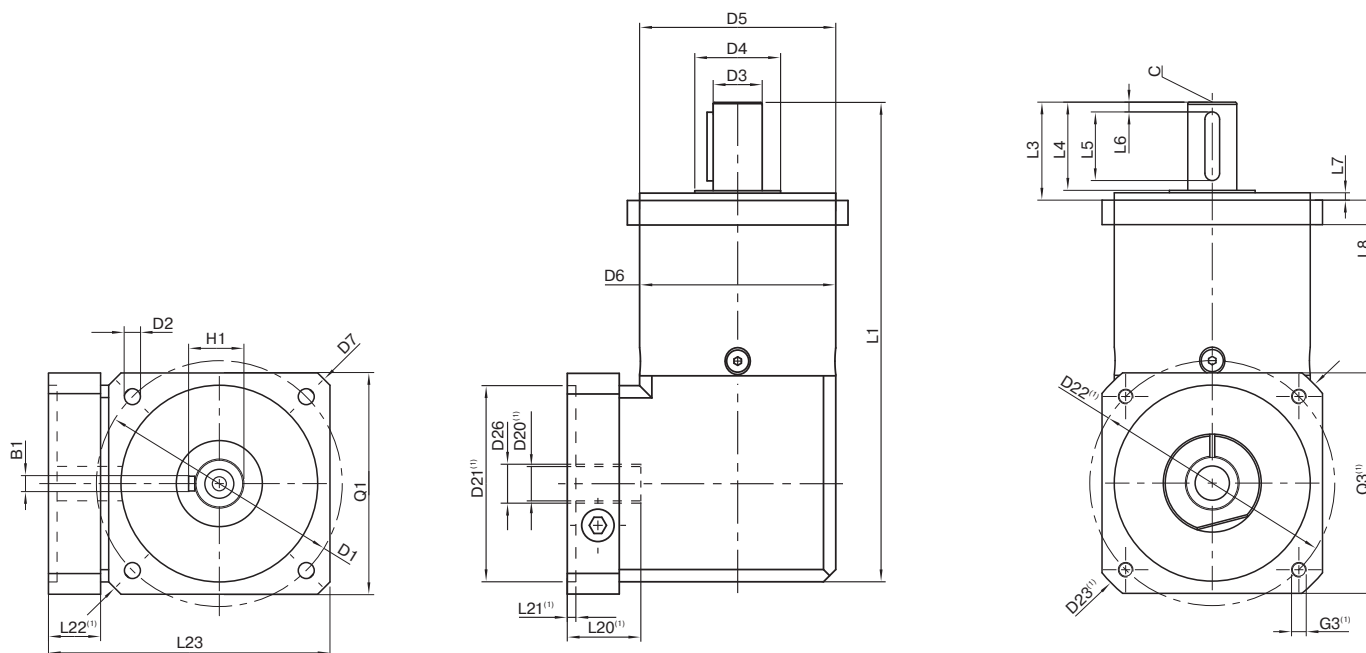

图示为带平键的 WPLQE080 / 1 级 / 附带平键的输出轴 / 19 mm 锁紧系统 / 适配电机法兰 - 2 件式 - 正方形通用法兰 / B5 电机法兰类型
 Drawing corresponds to a WPLQE080 / 1-stage / output shaft with feather key / 19 mm clamping system / motor adaptation - 2-part - square universal flange / B5 flange type motor

(1) 具体尺寸视电机/减速机法兰而定。可以在 www.neugart.com 下 Tec Data Finder 中针对每个电机适配电机特有的输入法兰几何尺寸。
 (1) The dimensions vary with the motor/gearbox flange. The input flange dimensions can be retrieved for each specific motor in Tec Data Finder at www.neugart.com

几何尺寸 ⁽²⁾	Geometry ⁽²⁾			WPLQE060	WPLQE080	WPLQE120	p ⁽³⁾	Code
输出端安装孔节圆直径	Pitch circle diameter output	D1		75	100	130		
输出端安装孔直径	Mounting bore output	D2	4x	5,5	6,5	8,5		
输出轴直径	Shaft diameter output	D3	h7	16	20	25		
输出轴轴肩直径	Shaft collar output	D4		20	35	35		
输出端定位凸台直径	Centering diameter output	D5	h7	60	80	110		
箱体直径	Housing diameter	D6		60	80	115		
输出法兰对角线尺寸	Diagonal dimension output	D7		92	116	145		
输出端法兰外方	Flange cross section output	Q1	■	70	90	115		
总长	Total length	L1		152	195,5	274,5	1	
				164,5	213	302,5	2	
				177	230,5	330	3	
输出轴轴长	Shaft length output	L3		32	40	55		
输出端定位凸台深度	Centering depth output	L7		3	3	4		
输出端法兰厚度	Flange thickness output	L8		10	10	15		
最小总高度	Min. overall height	L23		90,5	114,5	145,5		
电机轴直径 j6/k6	Motor shaft diameter j6/k6	D20		更多信息见第 163/164 页 More information on page 163/164				
输入端锁紧系统直径	Clamping system diameter input	D26		更多信息见第 163/164 页 More information on page 163/164				
带平键的输出轴 (DIN 6885-1)	Output shaft with feather key (DIN 6885-1)			A 5x5x20	A 6x6x28	A 8x7x40		A
平键宽度 (DIN 6885-1)	Feather key width (DIN 6885-1)	B1		5	6	8		
含平键在内的轴高 (DIN 6885-1)	Shaft height including feather key (DIN 6885-1)	H1		18	22,5	28		
到轴肩的距离	Shaft length from shoulder	L4		28	36	50		
平键长度	Feather key length	L5		20	28	40		
到轴端的距离	Distance from shaft end	L6		4	4	5		
中心孔 DIN 332, DR 形	Center hole (DIN 332, type DR)	C		M5x12,5	M6x16	M10x22		
光滑输出轴	Smooth output shaft							B
到轴肩的距离	Shaft length from shoulder	L4		28	36	50		

(2) 所有的尺寸单位为mm
 (3) 减速机级数

(2) Dimensions in mm
 (3) Number of stages



WPLPE

经济型直角行星减速机，适用于承载力很大的工况中
安装灵活，终生润滑，免维护

WPLPE是我们的经济型系列中广受欢迎的直角型减速机：它能节约空间，同时性能强大、价格合理。您可以把您的驱动元件直接安装到输出轴上，后者超强的深沟球轴承可以承受较高的径向力和轴向力。

The economical right angle planetary gearbox for particularly high forces – flexible installation options and lifetime lubrication

The **WPLPE** is the sought-after angle solution from our Economy range: space-saving yet powerful at an attractive price. You attach your drive elements directly to the output shaft, which can also withstand high radial forces thanks to extra-strong deep groove ball bearings.

额定扭矩

Nominal output torque **5 - 195 Nm**



径向力

Radial force **800 - 2500 N**

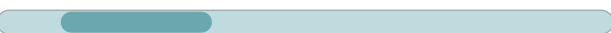

轴向力

Axial force **1000 - 4000 N**



回程间隙

Torsional backlash **11 - 25 arcmin**



防护等级

Protection class **IP54**



结构尺寸

Frame sizes

50

70

90

120

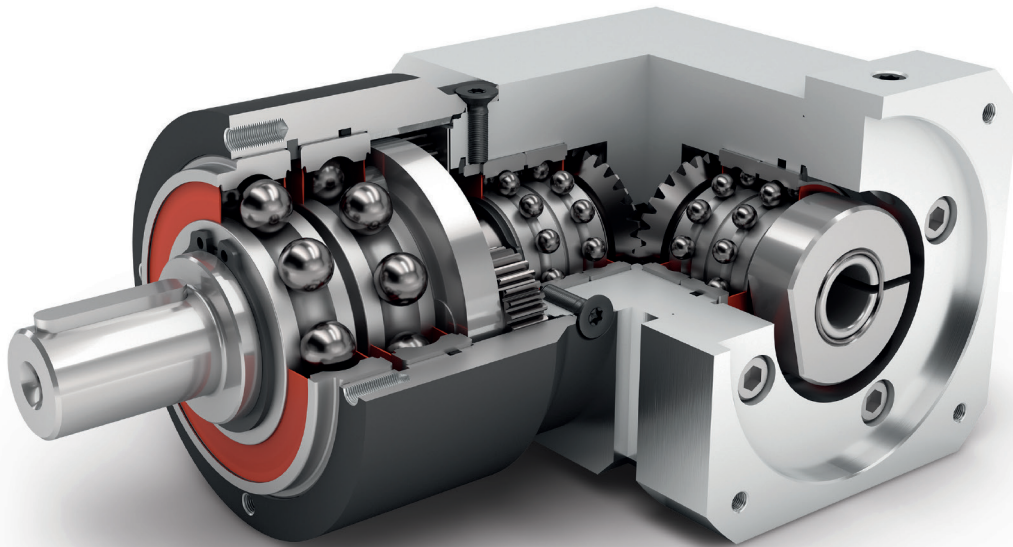

经济型
Economy Line



直角型减速机
Right angle gearbox



直齿
Spur gear

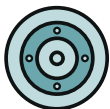

圆形输出法兰
Round type output flange



行星齿轮架
Planet carrier in disc design

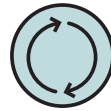

旋转方向 同方向
Equidirectional rotation



锥齿轮 直角型
Bevel gear right angle stage



增强深沟球轴承
Reinforced deep groove ball bearings



可选：喷漆表面
——RAL 9005 黑色
Option: Painted surface
- RAL 9005 Jet black

技术特点的详细解释，请从第173页读起。
Detailed explanations of the technical features starting on page 173.

Code	减速机参数	Gearbox characteristics			WPLPE050	WPLPE070	WPLPE090	WPLPE120	p ⁽¹⁾	
	使用寿命 (L _{10h})	Service life (L _{10h})	t _L	h	20.000					
	T _{2N} × 0,88 时的使用寿命	Service life at T _{2N} × 0,88			30.000					
	满载时效率 ⁽²⁾	Efficiency at full load ⁽²⁾	η	%	95				1	
					94				2	
	最低工作温度	Min. operating temperature	T _{min}	°C	-25					
	最高工作温度	Max. operating temperature	T _{max}		90					
	防护等级	Protection class					IP54			
S	标准润滑	Standard lubrication					润滑脂(终生润滑) / Grease (lifetime lubrication)			
F	食品级润滑	Food grade lubrication					润滑脂(终生润滑) / Grease (lifetime lubrication)			
L	低温润滑 ⁽³⁾	Low temperature lubrication ⁽³⁾					润滑脂(终生润滑) / Grease (lifetime lubrication)			
	安装位置	Installation position					任意 / Any			
S	标准回程间隙	Standard backlash	j _t	arcmin	< 21	< 16	< 13	< 11	1	
					< 25	< 18	< 15	< 13	2	
	抗扭刚度 ⁽²⁾	Torsional stiffness ⁽²⁾	c _G	Nm / arcmin	0,5 - 0,8	2,2 - 4,1	4,7 - 10,8	13,1 - 28,0	1	
					0,7 - 1,1	3,3 - 5,7	9,7 - 15,7	21,0 - 42,5	2	
	减速机重量 ⁽²⁾	Gearbox weight ⁽²⁾	m _G	kg	0,8	2,1 - 2,2	4,8	11,4 - 11,5	1	
					1,0 - 1,3	2,4 - 2,6	5,4 - 5,6	13,3 - 13,6	2	
S	标准的箱体表面	Standard surface					箱体: 钢 - 热处理后氧化 (黑色) Housing: Steel - heat-treated and post-oxidized (black)			
B	喷漆表面	Painted surface					RAL 9005 黑色 RAL 9005 Jet black			
	运行噪音 ⁽⁴⁾	Running noise ⁽⁴⁾	Q _G	dB(A)	68	70	73	75		
	基于减速机输入法兰的最大弯矩 ⁽⁵⁾	Max. bending moment based on the gearbox input flange ⁽⁵⁾	M _b	Nm	2	5	10,5	26		

输出轴载荷	Output shaft loads			WPLPE050	WPLPE070	WPLPE090	WPLPE120	p ⁽¹⁾
20.000 h 径向力 ⁽⁶⁾⁽⁷⁾	Radial force for 20,000 h ⁽⁶⁾⁽⁷⁾	F _{r20.000h}	N	800	1050	1900	2500	
20.000 h 轴向力 ⁽⁶⁾⁽⁷⁾	Axial force for 20,000 h ⁽⁶⁾⁽⁷⁾	F _{a20.000h}		1000	1350	2000	4000	
30.000 h 径向力 ⁽⁶⁾⁽⁷⁾	Radial force for 30,000 h ⁽⁶⁾⁽⁷⁾	F _{r30.000h}		700	900	1700	2150	
30.000 h 轴向力 ⁽⁶⁾⁽⁷⁾	Axial force for 30,000 h ⁽⁶⁾⁽⁷⁾	F _{a30.000h}		800	1000	1500	3000	
最大径向力 ⁽⁷⁾⁽⁸⁾	Maximum radial force ⁽⁷⁾⁽⁸⁾	F _{r Stat}		1300	1650	3100	4000	
最大轴向力 ⁽⁷⁾⁽⁸⁾	Maximum axial force ⁽⁷⁾⁽⁸⁾	F _{a Stat}		1000	2100	3800	5900	
20.000 h 倾斜力矩 ⁽⁶⁾⁽⁸⁾	Tilting moment for 20,000 h ⁽⁶⁾⁽⁸⁾	M _{K20.000h}	Nm	26	43	99	168	
30.000 h 倾斜力矩 ⁽⁶⁾⁽⁸⁾	Tilting moment for 30,000 h ⁽⁶⁾⁽⁸⁾	M _{K30.000h}		23	36	89	144	

转动惯量	Moment of inertia			WPLPE050	WPLPE070	WPLPE090	WPLPE120	p ⁽¹⁾
转动惯量 ⁽²⁾	Mass moment of inertia ⁽²⁾	J	kgcm ²	0,032 - 0,052	0,207 - 0,318	0,877 - 1,361	2,686 - 4,073	1
				0,031 - 0,048	0,206 - 0,315	0,859 - 1,197	2,643 - 3,643	2

(1) 减速机级数
 (2) 传动比相关的数值可在 Tec Data Finder 中检索 - www.neugart.com
 (3) T_{min} = -40°C. 理想运行温度最高为 50°C
 (4) 距离减速机 1 m 时: 在输入转速为 n₁=3000 min⁻¹ 且无负荷时测得: i=5
 (5) 最大电机重量* (单位: kg) = 0.2 × M_b / 电机长度 (单位: m)
 * 电机重量对称分布
 * 水平和固定的安装位置
 (6) 数据以 n₂=100 min⁻¹ 的输出轴转速为准。
 (7) 以输出轴中心为准
 (8) 更改 T_{2N}, F_r, F_a 以及周期和轴承使用寿命时, 数值存在偏差 (部分较高)。利用 NCP 针对应用进行专门设计 - www.neugart.com

(1) Number of stages
 (2) The ratio-dependent values can be retrieved in Tec Data Finder - www.neugart.com
 (3) T_{min} = -40°C. Optimal operating temperature max. 50°C
 (4) Sound pressure level from 1 m, measured on input running at n₁=3000 rpm no load; i=5
 (5) Max. motor weight* in kg = 0.2 × M_b / motor length in m
 * with symmetrically distributed motor weight
 * with horizontal and stationary mounting
 (6) These values are based on an output shaft speed of n₂=100 rpm
 (7) Based on center of output shaft
 (8) Other (sometimes higher) values following changes to T_{2N}, F_r, F_a, cycle, and service life of bearing. Application specific configuration with NCP - www.neugart.com

输出扭矩	Output torques			WPLPE050	WPLPE070	WPLPE090	WPLPE120	i ⁽¹⁾	p ⁽²⁾		
额定输出扭矩 ⁽³⁾⁽⁴⁾	Nominal output torque ⁽³⁾⁽⁴⁾	T _{2N}	Nm	4,5	14	40 ⁽⁵⁾	80 ⁽⁵⁾	3	1		
				6	19	53 ⁽⁵⁾	105 ⁽⁵⁾	4			
				7,5	24	67 ⁽⁵⁾	130 ⁽⁵⁾	5			
				8,5	25	65	135	7			
				6	18	50	120	8			
				5	15	38	95	10			
				12	33	97	157	9			
				15	33	90	195	12			
						13	33	82	172	15	2
						15	33	90	195	16	
						15	33	90	195	20	
						13	30	82	172	25	
						15	33	90	195	32	
						13	30	82	172	40	
						7,5	18	50	120	64	
						5	15	38	95	100	
最大输出扭矩 ⁽⁴⁾⁽⁶⁾	Max. output torque ⁽⁴⁾⁽⁶⁾	T _{2max}	Nm	7	22	64	128	3	1		
				10	30	85	168	4			
				12	38	107	208	5			
				13,5	40	104	216	7			
				10	29	80	192	8			
				8	24	61	152	10			
				19	53	155	251	9			
				24	53	144	312	12			
						21	53	131	275	15	2
						24	53	144	312	16	
						24	53	144	312	20	
						21	48	131	275	25	
						24	53	144	312	32	
						21	48	131	275	40	
						12	29	80	192	64	
						8	24	61	152	100	

WPLPE

⁽¹⁾ 传动比 (i=n₁/n₂)
⁽²⁾ 减速机级数
⁽³⁾ 利用 NCP 针对应用进行专门设计 – www.neugart.com
⁽⁴⁾ 平键 (代码 "A")时的数值; 针对交变载荷
⁽⁵⁾ T_{2N} 作用时 寿命不是10.000 h
⁽⁶⁾ 允许输出轴转动30.000转; 参见第 166 页

⁽¹⁾ Ratios (i=n₁/n₂)
⁽²⁾ Number of stages
⁽³⁾ Application specific configuration with NCP – www.neugart.com
⁽⁴⁾ Values for feather key (code "A"): for repeated load
⁽⁵⁾ Different service life: 10,000 h at T_{2N}
⁽⁶⁾ 30,000 rotations of the output shaft permitted; see page 167

输出扭矩	Output torques			WPLPE050	WPLPE070	WPLPE090	WPLPE120	i ⁽¹⁾	p ⁽²⁾			
急停扭矩 ⁽³⁾	Emergency stop torque ⁽³⁾	T _{2Stop}	Nm	22,5	66	180	360	3	1			
				28	86	240	474	4				
				35	80	220	500	5				
				26	80	178	340	7				
				27	80	190	380	8				
				25	70	170	430	10				
							33	88	260	500	9	2
							40	88	240	520	12	
							36	88	220	500	15	
							40	88	240	520	16	
							40	88	240	520	20	
							36	80	220	500	25	
							40	88	240	520	32	
							36	80	220	500	40	
							27	80	190	380	64	
							27	80	170	430	100	

输入转速	Input speeds			WPLPE050	WPLPE070	WPLPE090	WPLPE120	i ⁽¹⁾	p ⁽²⁾									
T _{2N} 和 S1 时的平均热输入转速 ⁽⁴⁾⁽⁵⁾	Average thermal input speed at T _{2N} and S1 ⁽⁴⁾⁽⁵⁾	n _{1N}	min ⁻¹	5000	4200 ⁽⁶⁾	3000 ⁽⁶⁾	2350 ⁽⁶⁾	3	1									
				5000	4500 ⁽⁶⁾	3150 ⁽⁶⁾	2450 ⁽⁶⁾	4										
				5000	4500 ⁽⁶⁾	3250 ⁽⁶⁾	2600 ⁽⁶⁾	5										
				5000	4500 ⁽⁶⁾	3950 ⁽⁶⁾	3100 ⁽⁶⁾	7										
				5000	4500	4000 ⁽⁶⁾	3450 ⁽⁶⁾	8										
				5000	4500	4000	3500 ⁽⁶⁾	10										
								5000	4500 ⁽⁶⁾	3500 ⁽⁶⁾	2950 ⁽⁶⁾	9	2					
								5000	4500	4000 ⁽⁶⁾	3050 ⁽⁶⁾	12						
								5000	4500	4000 ⁽⁶⁾	3450 ⁽⁶⁾	15						
								5000	4500	4000 ⁽⁶⁾	3450 ⁽⁶⁾	16						
								5000	4500	4000 ⁽⁶⁾	3500 ⁽⁶⁾	20						
								5000	4500	4000	3500 ⁽⁶⁾	25						
								5000	4500	4000	3500	32						
								5000	4500	4000	3500	40						
								5000	4500	4000	3500	64						
								5000	4500	4000	3500	100						
								最高机械输入转速 ⁽⁴⁾	Max. mechanical input speed ⁽⁴⁾	n _{1Limit}	min ⁻¹	18000		13000	7000	6500		

⁽¹⁾ 传动比 (i=n₁/n₂)

⁽²⁾ 减速级数

⁽³⁾ 允许 1000 次

⁽⁴⁾ 利用 NCP 针对应用设计转速 – www.neugart.com

⁽⁵⁾ 定义请参见第 166 页

⁽⁶⁾ 在 50% T_{2N} 输出和 S1 模式下的平均热输入转速

⁽¹⁾ Ratios (i=n₁/n₂)

⁽²⁾ Number of stages

⁽³⁾ Permitted 1000 times

⁽⁴⁾ Application-specific speed configurations with NCP – www.neugart.com

⁽⁵⁾ See page 167 for the definition

⁽⁶⁾ Average thermal input speed at 50% T_{2N} and S1

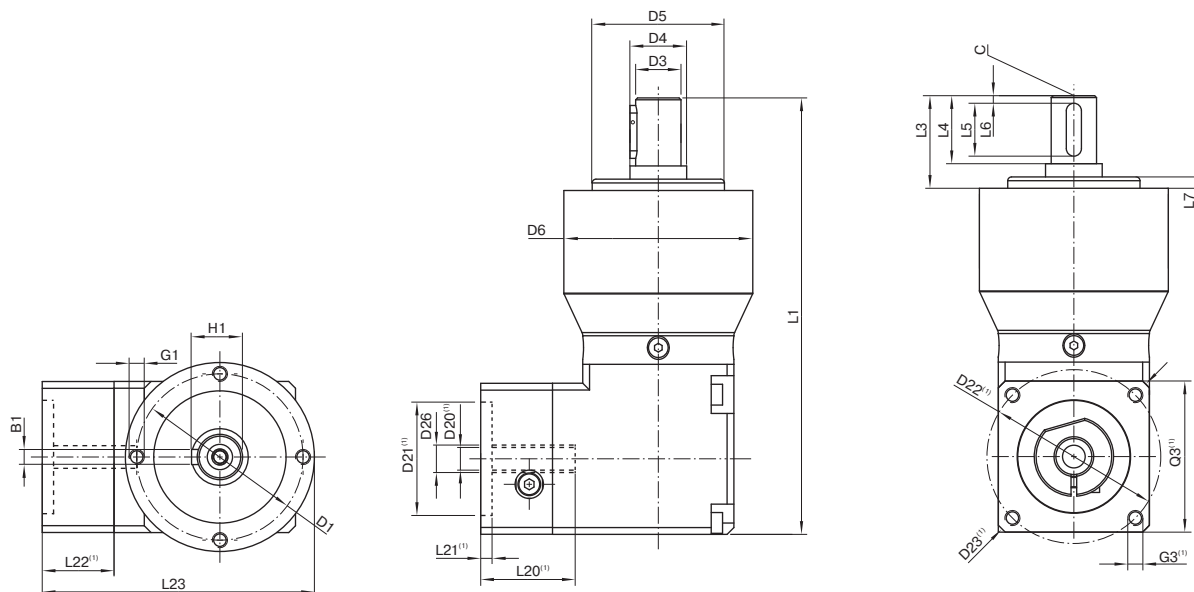

图示为带平键的 WPLPE090 / 1 级 / 附带平键的输出轴 / 19 mm 锁紧系统 / 适配电机法兰 - 2 件式 - 正方形通用法兰 / B5 电机法兰类型
 Drawing corresponds to a WPLPE090 / 1-stage / output shaft with feather key / 19 mm clamping system / motor adaptation - 2-part - square universal flange / B5 flange type motor

⁽¹⁾ 具体尺寸视电机/减速机法兰而定。可以在 www.neugart.com 下 Tec Data Finder 中针对每个电机适配电机特有的输入法兰几何尺寸。
⁽¹⁾ The dimensions vary with the motor/gearbox flange. The input flange dimensions can be retrieved for each specific motor in Tec Data Finder at www.neugart.com

几何尺寸 ⁽²⁾	Geometry ⁽²⁾			WPLPE050	WPLPE070	WPLPE090	WPLPE120	p ⁽³⁾	Code
输出端安装孔节圆直径	Pitch circle diameter output	D1		44	62	80	108		
输出轴直径	Shaft diameter output	D3	k7	12	16	22	32		
输出轴轴肩直径	Shaft collar output	D4		15	30	35	50		
输出端定位凸台直径	Centering diameter output	D5	h7	35	52	68	90		
箱体直径	Housing diameter	D6		50	70	90	120		
安装螺纹 x 深度	Mounting thread x depth	G1	4x	M4x8	M5x8	M6x9	M8x20		
总长	Total length	L1		115,5	152,5	197,5	265	1	
				128	165,5	215,5	292,5	2	
输出轴轴长	Shaft length output	L3		24,5	36	46	68		
输出端定位凸台深度	Centering depth output	L7		3	3	4	5		
最小总高度	Min. overall height	L23		67	90,5	114,5	148		
电机轴直径j6/k6	Motor shaft diameter j6/k6	D20		更多信息见第 163/164 页 More information on page 163/164					
输入端锁紧系统直径	Clamping system diameter input	D26							
带平键的输出轴 (DIN 6885-1)	Output shaft with feather key (DIN 6885-1)			A 4x4x14	A 5x5x25	A 6x6x32	A 10x8x50		A
平键宽度 (DIN 6885-1)	Feather key width (DIN 6885-1)	B1		4	5	6	10		
含平键在内的轴高 (DIN 6885-1)	Shaft height including feather key (DIN 6885-1)	H1		13,5	18	24,5	35		
到轴肩的距离	Shaft length from shoulder	L4		18	28	36	58		
平键长度	Feather key length	L5		14	25	32	50		
到轴端的距离	Distance from shaft end	L6		2	2	2	4		
中心孔 (DIN 332, DR 形)	Center hole (DIN 332, type DR)	C		M4x10	M5x12,5	M8x19	M12x28		
光滑输出轴	Smooth output shaft								B
到轴肩的距离	Shaft length from shoulder	L4		18	28	36	58		

⁽²⁾ 所有的尺寸单位为mm
⁽³⁾ 减速机级数

⁽²⁾ Dimensions in mm
⁽³⁾ Number of stages

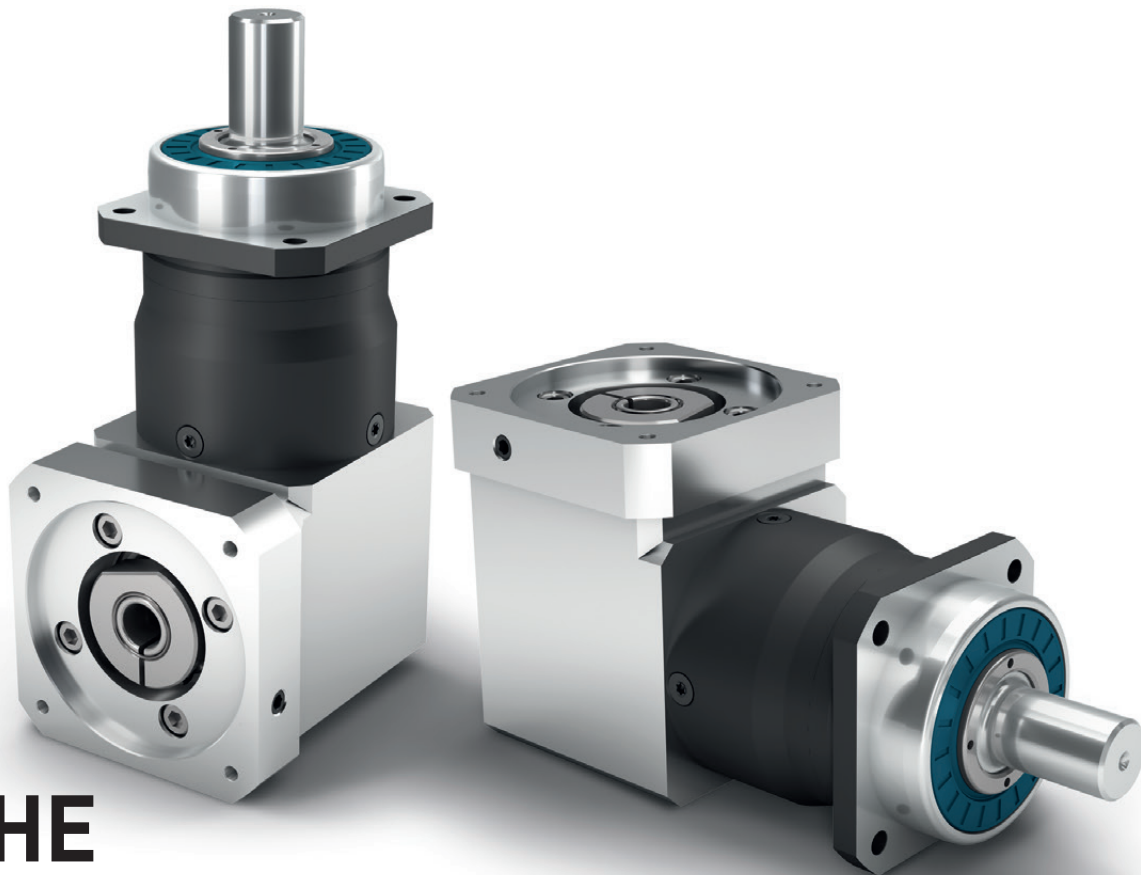

WPLHE

经济实惠且带有强大的输出轴承： WPLHE 直角行星减速机

节约轴向空间，经济实惠，防护等级IP65，专为承受高径向力和轴向力的输出端而设计：**WPLHE** 集合了已成功 PLHE 的全部优势。这是世界上首个将经济型减速机与高精度减速机组合的直角行星减速机。

Economical and with a heavy-duty output bearing: The WPLHE right-angle gearbox

Axially space-saving, economical, IP65-compliant and designed for high radial and axial forces at the output: The **WPLHE** combines all the advantages of the successful PLHE, the world's first combination of the Economy and Precision gearboxes, as a right-angle variant.

额定扭矩
Nominal output torque **14 - 260 Nm**

径向力
Radial force **3200 - 6000 N**

轴向力
Axial force **4400 - 8000 N**

回程间隙
Torsional backlash **11 - 18 arcmin**

防护等级
Protection class **IP65**

结构尺寸
Frame sizes

60

80

120

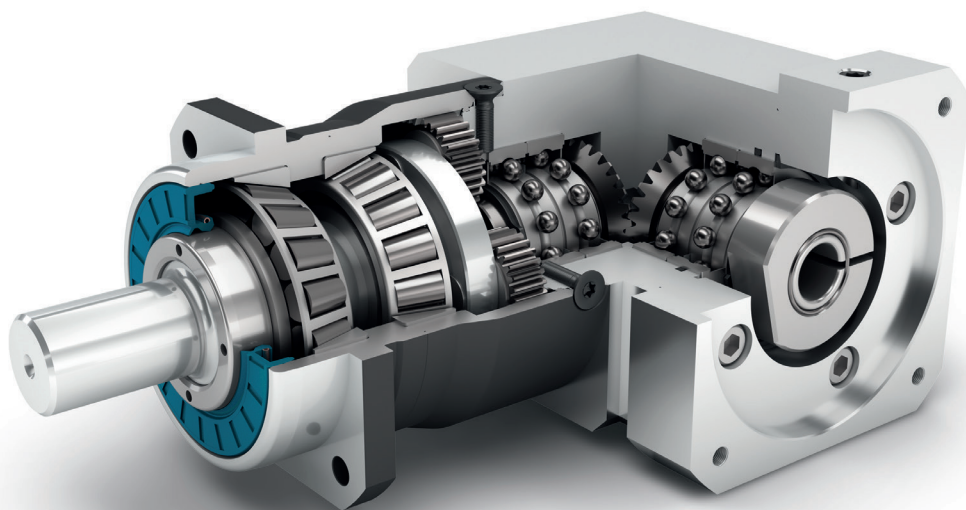

WPLHE



经济型
Economy Line



直角型减速机
Right angle gearbox



直齿
Spur gear



正方形输出法兰
Square type output flange



径向轴密封
Rotary shaft seal



行星齿轮架
Planet carrier in disc design



0可选：装有小齿轮的高精度减速机
132页
Option: Planetary gearbox with
mounted pinion on page 132



旋转方向 同方向
Equidirectional rotation

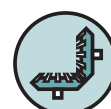

锥齿轮 直角型
Bevel gear right angle stage



配有预紧的圆锥滚子轴承
Preloaded tapered roller bearings



径向轴密封
Rotary shaft seal



可选：花键输出轴 (DIN 5480)
Option: Splined output shaft (DIN 5480)



可选：喷漆表面
——RAL 9005 黑色
Option: Painted surface
– RAL 9005 Jet black

技术特点的详细解释，请从第173页读起。
Detailed explanations of the technical features starting on page 173.

Code	减速机参数	Gearbox characteristics			WPLHE060	WPLHE080	WPLHE120	p ⁽¹⁾
	使用寿命 (L _{10h})	Service life (L _{10h})	t _L	h	20.000			
	T _{2N} × 0,88 时的使用寿命	Service life at T _{2N} × 0,88			30.000			
	满载时效率 ⁽²⁾	Efficiency at full load ⁽²⁾	η	%	94			
	最低工作温度	Min. operating temperature	T _{min}	°C	-25			
	最高工作温度	Max. operating temperature	T _{max}		90			
		防护等级	Protection class	IP65				
S	标准润滑	Standard lubrication	润滑脂(终生润滑) / Grease (lifetime lubrication)					
F	食品级润滑	Food grade lubrication	润滑脂(终生润滑) / Grease (lifetime lubrication)					
L	低温润滑 ⁽³⁾	Low temperature lubrication ⁽³⁾	润滑脂(终生润滑) / Grease (lifetime lubrication)					
	安装位置	Installation position	任意 / Any					
S	标准回程间隙	Standard backlash	j _t	arcmin	< 16	< 13	< 11	1
					< 18	< 15	< 13	2
	抗扭刚度 ⁽²⁾	Torsional stiffness ⁽²⁾	c _G	Nm / arcmin	1,8 - 3,4	4,1 - 9,0	11,2 - 20,5	1
					2,5 - 4,5	7,3 - 12,1	16,7 - 27,0	2
	减速机重量 ⁽²⁾	Gearbox weight ⁽²⁾	m _G	kg	2,3	4,6	10,9 - 11,0	1
					2,5	5,0 - 5,1	12,5 - 12,8	2
S	标准的箱体表面	Standard surface	箱体: 钢 - 热处理后氧化 (黑色) Housing: Steel - heat-treated and post-oxidized (black)					
B	喷漆表面	Painted surface	RAL 9005 黑色 RAL 9005 Jet black					
	运行噪音 ⁽⁴⁾	Running noise ⁽⁴⁾	Q _G	dB(A)	70	73	75	
	基于减速机输入法兰的最大弯矩 ⁽⁵⁾	Max. bending moment based on the gearbox input flange ⁽⁵⁾	M _b	Nm	5	10,5	26	

输出轴载荷	Output shaft loads			WPLHE060	WPLHE080	WPLHE120	p ⁽¹⁾
20.000 h 径向力 ⁽⁶⁾⁽⁷⁾	Radial force for 20,000 h ⁽⁶⁾⁽⁷⁾	F _{r20.000h}	N	3200	5500	6000	
20.000 h 轴向力 ⁽⁶⁾⁽⁷⁾	Axial force for 20,000 h ⁽⁶⁾⁽⁷⁾	F _{a20.000h}		4400	6400	8000	
30.000 h 径向力 ⁽⁶⁾⁽⁷⁾	Radial force for 30,000 h ⁽⁶⁾⁽⁷⁾	F _{r30.000h}		3200	4800	5400	
30.000 h 轴向力 ⁽⁶⁾⁽⁷⁾	Axial force for 30,000 h ⁽⁶⁾⁽⁷⁾	F _{a30.000h}		3900	5700	7000	
最大径向力 ⁽⁷⁾⁽⁸⁾	Maximum radial force ⁽⁷⁾⁽⁸⁾	F _{r Stat}		3200	5500	6000	
最大轴向力 ⁽⁷⁾⁽⁸⁾	Maximum axial force ⁽⁷⁾⁽⁸⁾	F _{a Stat}		4400	6400	8000	
20.000 h 倾斜力矩 ⁽⁶⁾⁽⁸⁾	Tilting moment for 20,000 h ⁽⁶⁾⁽⁸⁾	M _{K20.000h}	Nm	191	383	488	
30.000 h 倾斜力矩 ⁽⁶⁾⁽⁸⁾	Tilting moment for 30,000 h ⁽⁶⁾⁽⁸⁾	M _{K30.000h}		191	335	439	

转动惯量	Moment of inertia			WPLHE060	WPLHE080	WPLHE120	p ⁽¹⁾
转动惯量 ⁽²⁾	Mass moment of inertia ⁽²⁾	J	kgcm ²	0,214 - 0,395	0,921 - 1,394	1,832 - 2,970	1
				0,208 - 0,344	0,906 - 1,246	1,818 - 2,787	2

(1) 减速机级数

(2) 传动比相关的数值可在 Tec Data Finder 中检索 - www.neugart.com

(3) T_{min} = -40°C. 理想运行温度最高为 50°C

(4) 距离减速机 1 m 时: 在输入转速为 n₁=3000 min⁻¹ 且无负荷时测得; i=5

(5) 最大电机重量* (单位: kg) = 0.2 × M_b / 电机长度 (单位: m)

* 电机重量对称分布

* 水平和固定的安装位置

(6) 数据以 n₂=100 min⁻¹ 的输出轴转速为准。

(7) 以输出轴中心为准

(8) 更改 T_{2N}, F_r, F_a 以及周期和轴承使用寿命时, 数值存在偏差 (部分较高)。利用 NCP 针对应用进行专门设计 - www.neugart.com

(1) Number of stages

(2) The ratio-dependent values can be retrieved in Tec Data Finder - www.neugart.com

(3) T_{min} = -40°C. Optimal operating temperature max. 50°C

(4) Sound pressure level from 1 m, measured on input running at n₁=3000 rpm no load; i=5

(5) Max. motor weight* in kg = 0.2 × M_b / motor length in m

* with symmetrically distributed motor weight

* with horizontal and stationary mounting

(6) These values are based on an output shaft speed of n₂=100 rpm

(7) Based on center of output shaft

(8) Other (sometimes higher) values following changes to T_{2N}, F_r, F_a, cycle, and service life of bearing. Application specific configuration with NCP - www.neugart.com

输出扭矩	Output torques			WPLHE060	WPLHE080	WPLHE120	i ⁽¹⁾	p ⁽²⁾
额定输出扭矩 ⁽³⁾⁽⁴⁾	Nominal output torque ⁽³⁾⁽⁴⁾	T _{2N}	Nm	14	40 ⁽⁵⁾	80 ⁽⁵⁾	3	1
				19	53 ⁽⁵⁾	105 ⁽⁵⁾	4	
				24	67 ⁽⁵⁾	130 ⁽⁵⁾	5	
				25	65	135	7	
				18	50	120	8	
				15	38	95	10	
				44 ⁽⁵⁾	130 ⁽⁵⁾	210 ⁽⁵⁾	9	2
				44	120 ⁽⁵⁾	260 ⁽⁵⁾	12	
				44	110	230	15	
				44	120	260	16	
				44	120	260	20	
				40	110	230	25	
				44	120	260	32	
				40	110	230	40	
				18	50	120	64	
				15	38	95	100	
最大输出扭矩 ⁽⁴⁾⁽⁶⁾	Max. output torque ⁽⁴⁾⁽⁶⁾	T _{2max}	Nm	22	64	128	3	1
				30	85	168	4	
				38	107	208	5	
				40	104	216	7	
				29	80	192	8	
				24	61	152	10	
				70	208	336	9	2
				70	192	416	12	
				70	176	368	15	
				70	192	416	16	
				70	192	416	20	
				64	176	368	25	
				70	192	416	32	
				64	176	368	40	
				29	80	192	64	
				24	61	152	100	

WPLHE

(1) 传动比 (i=n₁/n₂)
 (2) 减速机级数
 (3) 利用 NCP 针对应用进行专门设计 – www.neugart.com
 (4) 平键 (代码 „A”)时的数值: 针对交变载荷
 (5) T_{2N} 作用时 寿命不是 10.000 h
 (6) 允许输出轴转动30.000转; 参见第 166 页

(1) Ratios (i=n₁/n₂)
 (2) Number of stages
 (3) Application specific configuration with NCP – www.neugart.com
 (4) Values for feather key (code “A”): for repeated load
 (5) Different service life: 10,000 h at T_{2N}
 (6) 30,000 rotations of the output shaft permitted; see page 167

输出扭矩	Output torques			WPLHE060	WPLHE080	WPLHE120	$i^{(1)}$	$p^{(2)}$
急停扭矩 ⁽³⁾	Emergency stop torque ⁽³⁾	T_{2Stop}	Nm	66	180	360	3	1
				86	240	474	4	
				80	220	500	5	
				80	178	340	7	
				80	190	380	8	
				70	170	430	10	
				88	260	500	9	2
				88	240	520	12	
				88	220	500	15	
				88	240	520	16	
				88	240	520	20	
				80	220	500	25	
				88	240	520	32	
				80	220	500	40	
				80	190	380	64	
				80	200	430	100	

输入转速	Input speeds			WPLHE060	WPLHE080	WPLHE120	$i^{(1)}$	$p^{(2)}$					
T_{2N} 和 S1 时的平均热输入转速 ⁽⁴⁾⁽⁵⁾	Average thermal input speed at T_{2N} and S1 ⁽⁴⁾⁽⁵⁾	n_{1N}	min^{-1}	2650 ⁽⁶⁾	2050 ⁽⁶⁾	2300 ⁽⁶⁾	3	1					
				3100 ⁽⁶⁾	2300 ⁽⁶⁾	2500 ⁽⁶⁾	4						
				3450 ⁽⁶⁾	2450 ⁽⁶⁾	2700 ⁽⁶⁾	5						
				4250 ⁽⁶⁾	3100 ⁽⁶⁾	3300 ⁽⁶⁾	7						
				4500 ⁽⁶⁾	3550 ⁽⁶⁾	3500 ⁽⁶⁾	8						
				4500	4000 ⁽⁶⁾	3500	10						
				3300 ⁽⁶⁾	2400 ⁽⁶⁾	2500 ⁽⁶⁾	9	2					
				3800 ⁽⁶⁾	2850 ⁽⁶⁾	2600 ⁽⁶⁾	12						
				4450 ⁽⁶⁾	3250 ⁽⁶⁾	3000 ⁽⁶⁾	15						
				4500 ⁽⁶⁾	3250 ⁽⁶⁾	3000 ⁽⁶⁾	16						
				4500 ⁽⁶⁾	3650 ⁽⁶⁾	3400 ⁽⁶⁾	20						
				4500	4000 ⁽⁶⁾	3500 ⁽⁶⁾	25						
				4500	4000 ⁽⁶⁾	3500 ⁽⁶⁾	32						
				4500	4000	3500	40						
				4500	4000	3500	64						
				4500	4000	3500	100						
				最高机械输入转速 ⁽⁴⁾	Max. mechanical input speed ⁽⁴⁾	n_{1Limit}	min^{-1}		13000	7000	6500		

⁽¹⁾ 传动比 ($i=n_1/n_2$)

⁽²⁾ 减速机级数

⁽³⁾ 允许 1000 次

⁽⁴⁾ 利用 NCP 针对应用设计转速 – www.neugart.com

⁽⁵⁾ 定义请参见第 166 页

⁽⁶⁾ 在 50% T_{2N} 输出和 S1 模式下的平均热输入转速

⁽¹⁾ Ratios ($i=n_1/n_2$)

⁽²⁾ Number of stages

⁽³⁾ Permitted 1000 times

⁽⁴⁾ Application-specific speed configurations with NCP – www.neugart.com

⁽⁵⁾ See page 167 for the definition

⁽⁶⁾ Average thermal input speed at 50% T_{2N} and S1

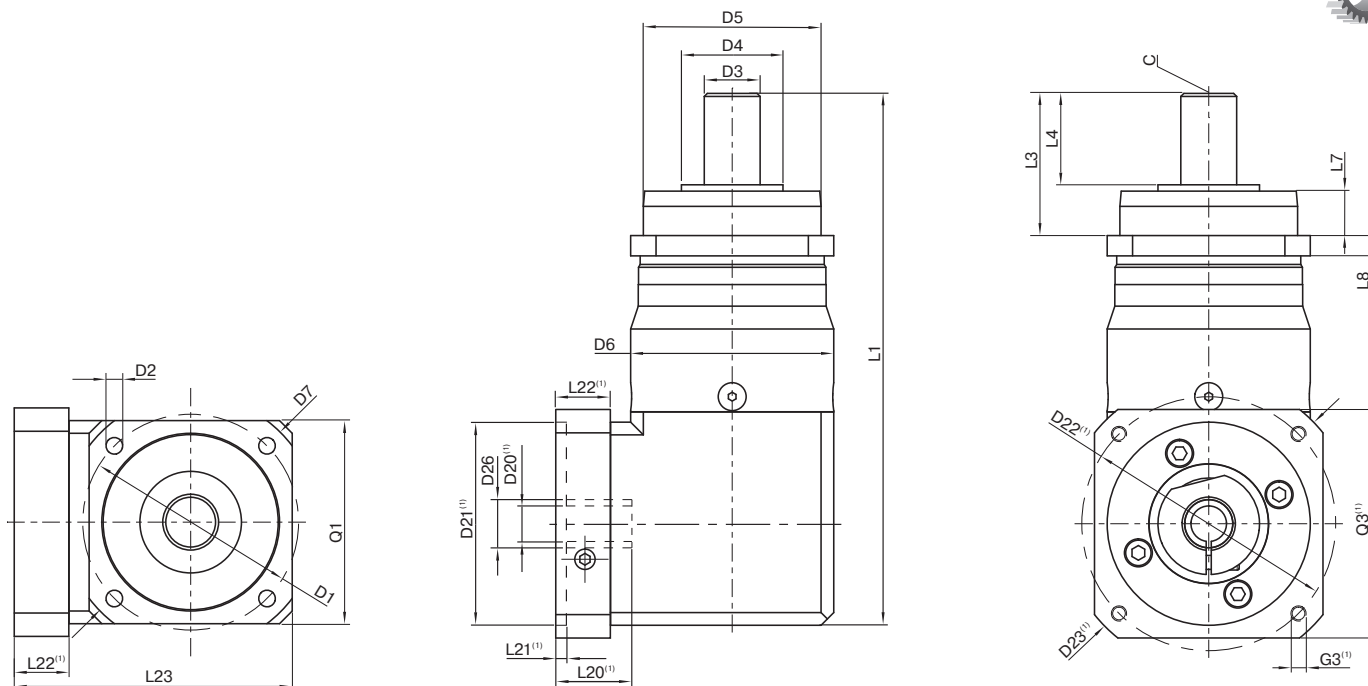

图示为带平键的 WPLHE080 / 1 级 / 光滑输出轴 / 19 mm 锁紧系统 / 适配电机法兰 - 2 件式 - 正方形通用法兰 / B5 电机法兰类型
 Drawing corresponds to a WPLHE080 / 1-stage / smooth output shaft / 19 mm clamping system / motor adaptation - 2-part - square universal flange / B5 flange type motor

(1) 具体尺寸视电机/减速机法兰而定。可以在 www.neugart.com 下 Tec Data Finder 中针对每个电机适配电机特有的输入法兰几何尺寸。
 (1) The dimensions vary with the motor/gearbox flange. The input flange dimensions can be retrieved for each specific motor in Tec Data Finder at www.neugart.com

几何尺寸 ⁽²⁾	Geometry ⁽²⁾			WPLHE060	WPLHE080	WPLHE120	p ⁽³⁾	Code
输出端安装孔节圆直径	Pitch circle diameter output	D1		68 - 75	85	120		
输出端安装孔直径	Mounting bore output	D2	4x	5,5	6,5	9,0		
输出轴直径	Shaft diameter output	D3	k7	16	22	32		
输出轴轴肩直径	Shaft collar output	D4		35	40	45		
输出端定位凸台直径	Centering diameter output	D5	h7	60	70	90		
箱体直径	Housing diameter	D6		60	80	115		
输出法兰对角线尺寸	Diagonal dimension output	D7		92	100	140		
输出端法兰外方	Flange cross section output	Q1	■	70	80	110		
总长	Total length	L1		168	209,5	272,5	1	
				180,5	227,5	300	2	
输出轴轴长	Shaft length output	L3		48	56	88		
输出端定位凸台深度	Centering depth output	L7		19	18	28		
输出端法兰厚度	Flange thickness output	L8		7	8	10		
最小总高度	Min. overall height	L23		90,5	109,5	145,5		
电机轴直径j6/k6	Motor shaft diameter j6/k6	D20		更多信息见第 163/164 页 More information on page 163/164				
输入端锁紧系统直径	Clamping system diameter input	D26		更多信息见第 163/164 页 More information on page 163/164				
带平键的输出轴 (DIN 6885-1)	Output shaft with feather key (DIN 6885-1)	-	-	A 5x5x25	A 6x6x28	A 10x8x50		
平键宽度 (DIN 6885-1)	Feather key width (DIN 6885-1)	B1		5	6	10		A
含平键在内的轴高 (DIN 6885-1)	Shaft height including feather key (DIN 6885-1)	H1		18	24,5	35		
到轴肩的距离	Shaft length from shoulder	L4		28	36	58		
平键长度	Feather key length	L5		25	28	50		
到轴端的距离	Distance from shaft end	L6		2	4	4		
中心孔 (DIN 332, DR 形)	Center hole (DIN 332, type DR)	C		M5x12,5	M8x19	M12x28		
光滑输出轴	Smooth output shaft							B
到轴肩的距离	Shaft length from shoulder	L4		28	36	58		
花键输出轴 (DIN 5480)	Splined output shaft (DIN 5480)			W16x0,8x18x6m	W22x1,25x16x6m	W32x1,25x24x6m		C
花键或键槽的长度	Width of gearing	L _v		15	15	15		
输出轴轴长	Shaft length output	L3		48	56	88		
到轴肩的距离	Shaft length from shoulder	L4		26	26	26		
中心孔 (DIN 332, DR 形)	Center hole (DIN 332, type DR)	C		M5x12,5	M8x19	M12x28		

(2) 所有的尺寸单位为mm
 (3) 减速机级数

(2) Dimensions in mm
 (3) Number of stages

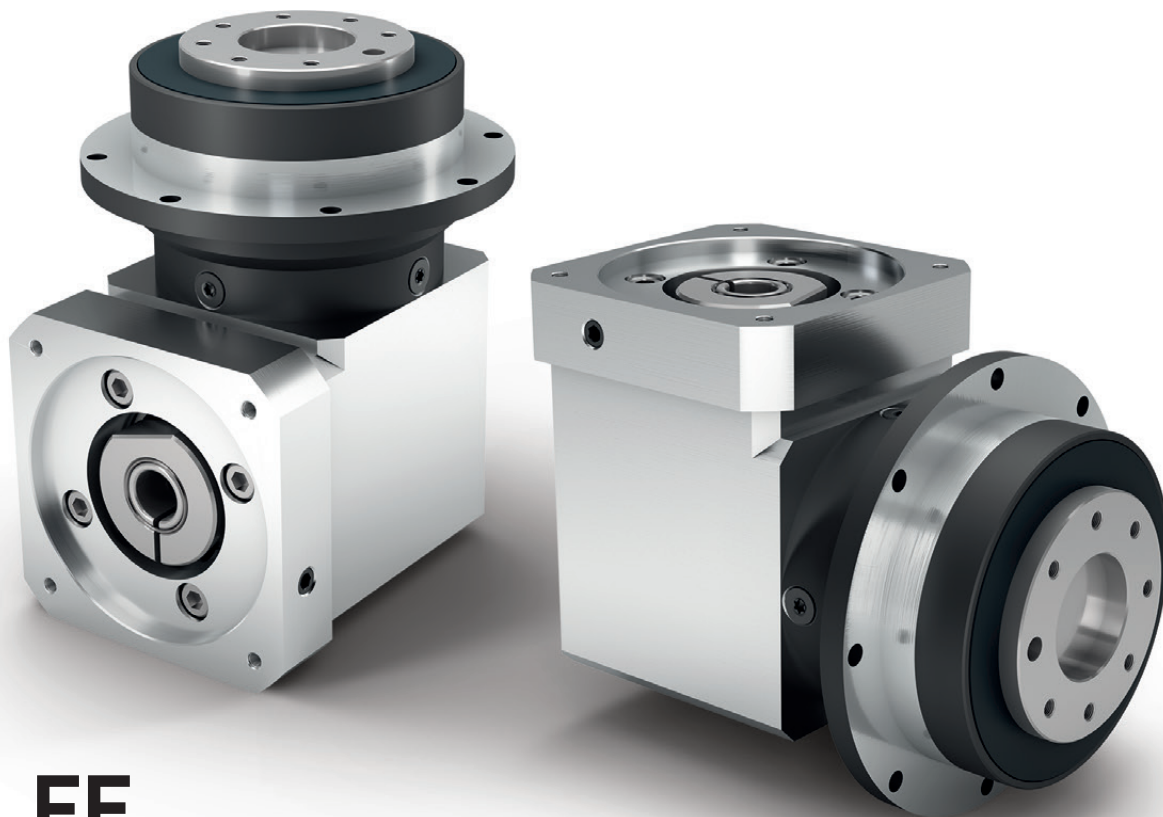

WPLFE

最短的直角行星减速机，带有法兰输出轴，具备较高的抗扭刚度

WPLFE 是我们带有紧凑型法兰输出轴的直角行星减速机。您可以节省多达三分之一的空间。它带有标准法兰接口，因此特别容易安装。它还集成了定位销孔，在安装时增加了牢固度。

The shortest right-angle gearbox with flange output shaft and high torsional stiffness

The **WPLFE** is our right-angle planetary gearbox with a compact flange output shaft. You save up to a third of the space. Its standardized flange interface makes it particularly easy to install. The integrated dowel pin drill hole provides additional stability during installation.

额定扭矩

Nominal output torque

14 - 260 Nm

径向力

Radial force

550 - 2400 N

轴向力

Axial force

1200 - 3300 N

回程间隙

Torsional backlash

11 - 18 arcmin

防护等级

Protection class

IP54

结构尺寸

Frame sizes

64

90

110

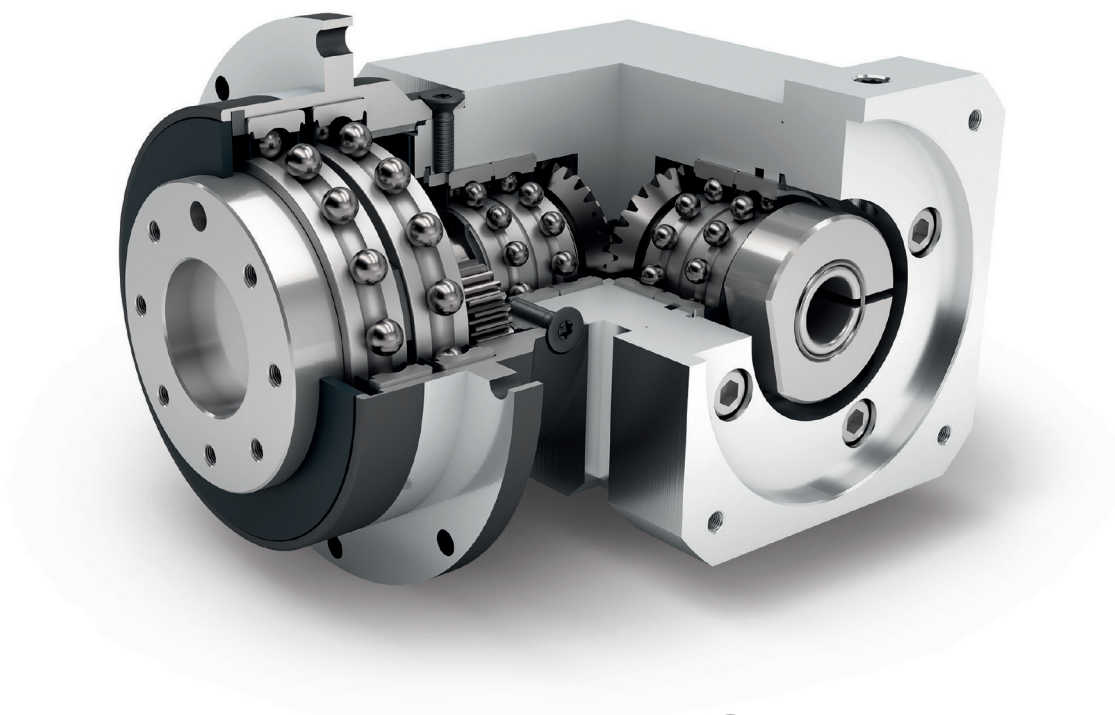

WPLFE



经济型
Economy Line



旋转方向 同方向
Equidirectional rotation



锥齿轮 直角型
Bevel gear right angle stage



低摩擦深沟球轴承
Low-friction deep groove ball bearings



行星齿轮架
Planet carrier in disc design



直角型减速机
Right angle gearbox



直齿
Spur gear



圆形特大号输出法兰
Extra large round type output flange



法兰输出轴 (按 ISO 9409-1 标准)
Flange output shaft (ISO 9409-1)



可选: 喷漆表面
——RAL 9005 黑色
Option: Painted surface
- RAL 9005 Jet black

技术特点的详细解释, 请从第173页读起。
Detailed explanations of the technical features starting on page 173.

Code	减速机参数	Gearbox characteristics			WPLFE064	WPLFE090	WPLFE110	p ⁽¹⁾
	使用寿命 (L _{10h})	Service life (L _{10h})	t _L	h	20.000			
	T _{2N} × 0,88 时的使用寿命	Service life at T _{2N} × 0,88			30.000			
	满载时效率 ⁽²⁾	Efficiency at full load ⁽²⁾	η	%	94			1
					93			2
	最低工作温度	Min. operating temperature	T _{min}	°C	-25			
	最高工作温度	Max. operating temperature	T _{max}		90			
	防护等级	Protection class				IP54		
S	标准润滑	Standard lubrication				润滑脂(终生润滑) / Grease (lifetime lubrication)		
F	食品级润滑	Food grade lubrication				润滑脂(终生润滑) / Grease (lifetime lubrication)		
L	低温润滑 ⁽³⁾	Low temperature lubrication ⁽³⁾				润滑脂(终生润滑) / Grease (lifetime lubrication)		
	安装位置	Installation position				任意 / Any		
S	标准回程间隙	Standard backlash	j _t	arcmin	< 16	< 13	< 11	1
					< 18	< 15	< 13	2
	抗扭刚度 ⁽²⁾	Torsional stiffness ⁽²⁾	c _G	Nm / arcmin	2,9 - 6,2	5,8 - 17,5	15,9 - 40,5	1
					5,1 - 11,6	15,9 - 37,5	29,5 - 83,0	2
	减速机重量 ⁽²⁾	Gearbox weight ⁽²⁾	m _G	kg	1,8	4,5 - 4,6	10,4 - 10,5	1
					2,0 - 2,1	5,0 - 5,2	12,1 - 12,5	2
S	标准的箱体表面	Standard surface				箱体: 钢 - 热处理后氧化 (黑色) Housing: Steel - heat-treated and post-oxidized (black)		
B	喷漆表面	Painted surface				RAL 9005 黑色 RAL 9005 Jet black		
	运行噪音 ⁽⁴⁾	Running noise ⁽⁴⁾	Q _G	dB(A)	70	73	75	
	基于减速机输入法兰的最大弯矩 ⁽⁵⁾	Max. bending moment based on the gearbox input flange ⁽⁵⁾	M _b	Nm	5	10,5	26	

输出轴载荷	Output shaft loads			WPLFE064	WPLFE090	WPLFE110	p ⁽¹⁾
20.000 h 径向力 ⁽⁶⁾⁽⁷⁾	Radial force for 20,000 h ⁽⁶⁾⁽⁷⁾	F _{r20.000h}	N	550	1400	2400	
20.000 h 轴向力 ⁽⁶⁾⁽⁷⁾	Axial force for 20,000 h ⁽⁶⁾⁽⁷⁾	F _{a20.000h}		1200	3000	3300	
30.000 h 径向力 ⁽⁶⁾⁽⁷⁾	Radial force for 30,000 h ⁽⁶⁾⁽⁷⁾	F _{r30.000h}		500	1200	2100	
30.000 h 轴向力 ⁽⁶⁾⁽⁷⁾	Axial force for 30,000 h ⁽⁶⁾⁽⁷⁾	F _{a30.000h}		1200	3000	3300	
最大径向力 ⁽⁷⁾⁽⁸⁾	Maximum radial force ⁽⁷⁾⁽⁸⁾	F _{r Stat}		900	2200	3800	
最大轴向力 ⁽⁷⁾⁽⁸⁾	Maximum axial force ⁽⁷⁾⁽⁸⁾	F _{a Stat}		1200	3300	5200	
20.000 h 倾斜力矩 ⁽⁶⁾⁽⁸⁾	Tilting moment for 20,000 h ⁽⁶⁾⁽⁸⁾	M _{K20.000h}	Nm	12	46	109	
30.000 h 倾斜力矩 ⁽⁶⁾⁽⁸⁾	Tilting moment for 30,000 h ⁽⁶⁾⁽⁸⁾	M _{K30.000h}		11	40	96	

转动惯量	Moment of inertia			WPLFE064	WPLFE090	WPLFE110	p ⁽¹⁾
转动惯量 ⁽²⁾	Mass moment of inertia ⁽²⁾	J	kgcm ²	0,217 - 0,428	0,909 - 1,735	2,751 - 4,739	1
				0,209 - 0,348	0,861 - 1,238	2,644 - 3,716	2

(1) 减速机级数
 (2) 传动比相关的数值可在 Tec Data Finder 中检索 - www.neugart.com
 (3) T_{min} = -40°C. 理想运行温度最高为 50°C
 (4) 距离减速机 1 m 时: 在输入转速为 n₁=3000 min⁻¹ 且无负荷时测得; i=5
 (5) 最大电机重量* (单位: kg) = 0.2 × M_b / 电机长度 (单位: m)
 * 电机重量对称分布
 * 水平和固定的安装位置
 (6) 数据以 n₂=100 min⁻¹ 的输出轴转速为准。
 (7) 以输出轴中心为准
 (8) 更改 T_{2N}, F_r, F_a 以及周期和轴承使用寿命时, 数值存在偏差 (部分较高)。利用 NCP 针对应用进行专门设计 - www.neugart.com

(1) Number of stages
 (2) The ratio-dependent values can be retrieved in Tec Data Finder - www.neugart.com
 (3) T_{min} = -40°C. Optimal operating temperature max. 50°C
 (4) Sound pressure level from 1 m, measured on input running at n₁=3000 rpm no load; i=5
 (5) Max. motor weight* in kg = 0.2 × M_b / motor length in m
 * with symmetrically distributed motor weight
 * with horizontal and stationary mounting
 (6) These values are based on an output shaft speed of n₂=100 rpm
 (7) Based on the end of the output shaft
 (8) Other (sometimes higher) values following changes to T_{2N}, F_r, F_a, cycle, and service life of bearing. Application specific configuration with NCP - www.neugart.com

输出扭矩	Output torques			WPLFE064	WPLFE090	WPLFE110	i ⁽¹⁾	p ⁽²⁾
额定输出扭矩 ⁽³⁾	Nominal output torque ⁽³⁾	T _{2N}	Nm	14	40 ⁽⁴⁾	80 ⁽⁴⁾	3	1
				19	53 ⁽⁴⁾	105 ⁽⁴⁾	4	
				24	67 ⁽⁴⁾	130 ⁽⁴⁾	5	
				25	65	135	7	
				18	50	120	8	
				15	38	95	10	
				44 ⁽⁴⁾	130 ⁽⁴⁾	210 ⁽⁴⁾	9	2
				44	120 ⁽⁴⁾	260 ⁽⁴⁾	12	
				44	110	230	15	
				44	120	260	16	
				44	120	260	20	
				40	110	230	25	
				44	120	260	32	
				40	110	230	40	
				18	50	120	64	
				15	38	95	100	
最大输出扭矩 ⁽⁵⁾	Max. output torque ⁽⁵⁾	T _{2max}	Nm	22	64	128	3	1
				30	85	168	4	
				38	107	208	5	
				40	104	216	7	
				29	80	192	8	
				24	61	152	10	
				70	208	336	9	2
				70	192	416	12	
				70	176	368	15	
				70	192	416	16	
				70	192	416	20	
				64	176	368	25	
				70	192	416	32	
				64	176	368	40	
				29	80	192	64	
				24	61	152	100	

⁽¹⁾ 传动比 (i=n₁/n₂)

⁽²⁾ 减速机级数

⁽³⁾ 利用 NCP 针对应用进行专门设计 – www.neugart.com

⁽⁴⁾ T_{2N} 作用时 寿命不是10.000 h

⁽⁵⁾ 允许输出轴转动30.000转; 参见第 166 页

⁽¹⁾ Ratios (i=n₁/n₂)

⁽²⁾ Number of stages

⁽³⁾ Application specific configuration with NCP – www.neugart.com

⁽⁴⁾ Different service life: 10,000 h at T_{2N}

⁽⁵⁾ 30,000 rotations of the output shaft permitted; see page 167

输出扭矩	Output torques			WPLFE064	WPLFE090	WPLFE110	$i^{(1)}$	$p^{(2)}$
急停扭矩 ⁽³⁾	Emergency stop torque ⁽³⁾	T_{2Stop}	Nm	66	180	360	3	1
				86	240	474	4	
				80	220	500	5	
				80	178	340	7	
				80	190	380	8	
				70	170	430	10	
				88	260	500	9	2
				88	240	520	12	
				88	220	500	15	
				88	240	520	16	
				88	240	520	20	
				80	220	500	25	
				88	240	520	32	
				80	220	500	40	
				80	190	380	64	
				80	200	430	100	

输入转速	Input speeds			WPLFE064	WPLFE090	WPLFE110	$i^{(1)}$	$p^{(2)}$					
T_{2N} 和 S1 时的平均热输入转速 ⁽⁴⁾⁽⁵⁾	Average thermal input speed at T_{2N} and S1 ⁽⁴⁾⁽⁵⁾	n_{1N}	min^{-1}	4000 ⁽⁶⁾	2800 ⁽⁶⁾	2200 ⁽⁶⁾	3	1					
				4400 ⁽⁶⁾	3000 ⁽⁶⁾	2400 ⁽⁶⁾	4						
				4500 ⁽⁶⁾	3200 ⁽⁶⁾	2600 ⁽⁶⁾	5						
				4500 ⁽⁶⁾	4000 ⁽⁶⁾	3000 ⁽⁶⁾	7						
				4500	4000 ⁽⁶⁾	3300 ⁽⁶⁾	8						
				4500	4000	3500 ⁽⁶⁾	10						
				4300 ⁽⁶⁾	2900 ⁽⁶⁾	2400 ⁽⁶⁾	9	2					
				4500 ⁽⁶⁾	3400 ⁽⁶⁾	2600 ⁽⁶⁾	12						
				4500 ⁽⁶⁾	3800 ⁽⁶⁾	3100 ⁽⁶⁾	15						
				4500 ⁽⁶⁾	3800 ⁽⁶⁾	3000 ⁽⁶⁾	16						
				4500	4000 ⁽⁶⁾	3400 ⁽⁶⁾	20						
				4500	4000 ⁽⁶⁾	3500 ⁽⁶⁾	25						
				4500	4000	3500 ⁽⁶⁾	32						
				4500	4000	3500	40						
				4500	4000	3500	64						
				4500	4000	3500	100						
				最高机械输入转速 ⁽⁴⁾	Max. mechanical input speed ⁽⁴⁾	n_{1Limit}	min^{-1}		13000	7000	6500		1
									13000	7000	6500		2

⁽¹⁾ 传动比 ($i=n_1/n_2$)

⁽²⁾ 减速级数

⁽³⁾ 允许 1000 次

⁽⁴⁾ 利用 NCP 针对应用设计转速 – www.neugart.com

⁽⁵⁾ 定义请参见第 166 页

⁽⁶⁾ 在 50% T_{2N} 输出和 S1 模式下的平均热输入转速

⁽¹⁾ Ratios ($i=n_1/n_2$)

⁽²⁾ Number of stages

⁽³⁾ Permitted 1000 times

⁽⁴⁾ Application-specific speed configurations with NCP – www.neugart.com

⁽⁵⁾ See page 167 for the definition

⁽⁶⁾ Average thermal input speed at 50% T_{2N} and S1

WPLFE064
WPLFE090

WPLFE110

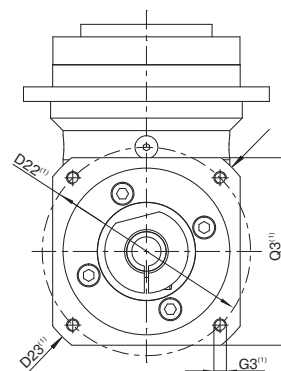
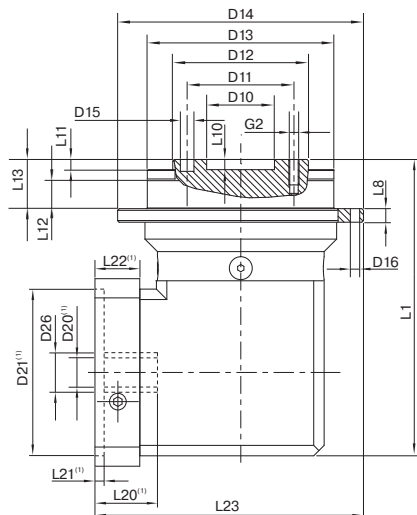
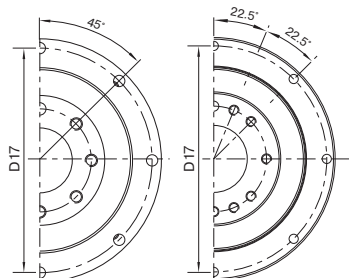

图示为带平键的 WPLFE090 / 1 级 / 带有配合销孔的法兰输出轴 / 19 mm 锁紧系统 / 适配电机法兰 - 2 件式 - 正方形通用法兰 / B5 电机法兰类型

Drawing corresponds to a WPLFE090 / 1-stage / flange output shaft with dowel hole / 19 mm clamping system / motor adaptation - 2-part - square universal flange / B5 flange type motor

⁽¹⁾ 具体尺寸视电机/减速机法兰而定。可以在 www.neugart.com 下 Tec Data Finder 中针对每个电机适配电机特有的输入法兰几何尺寸。

⁽¹⁾ The dimensions vary with the motor/gearbox flange. The input flange dimensions can be retrieved for each specific motor in Tec Data Finder at www.neugart.com

几何尺寸 ⁽²⁾	Geometry ⁽²⁾			WPLFE064	WPLFE090	WPLFE110	p ⁽³⁾	Code
输出端定位凹槽直径	Centering diameter output shaft	D10	H7	20	31,5	40		
输出端安装孔节圆直径	Pitch circle diameter output shaft	D11		31,5	50	63		
法兰输出轴的直径	Flange output shaft diameter	D12	h7	40	63	80		
输出法兰定位凸台直径	Centering diameter output flange	D13		64	90	110		
输出法兰直径	Flange diameter output	D14		86	118	145		
输出端安装孔直径	Mounting bore output	D16		4,5 8x45°	5,5 8x45°	5,5 8x45°		
输出法兰安装孔节圆直径	Pitch circle diameter output flange	D17		79	109	135		
总长	Total length	L1		110	149	198,5	1	
				122,5	165,5	225,5	2	
输出端法兰厚度	Flange thickness output	L8		4	7	8		
输出轴定位凸台深度	Centering depth output shaft	L10		4	6	6		
		L11		3	6	6		
输出法兰定位凸台深度	Centering depth output flange	L12		7,5	10,5	10,5		
输出法兰长度	Output flange length	L13		19,5	30,0	29,0		
最小总高度	Min. overall height	L23		98,5	129	160,5		
电机轴直径 j6/k6	Motor shaft diameter j6/k6	D20		更多信息见第 163/164 页 More information on page 163/164				
输入端锁紧系统直径	Clamping system diameter input	D26		更多信息见第 163/164 页 More information on page 163/164				
带有配合销孔的法兰输出轴 (ISO 9409-1)	Flange output shaft with dowel hole (ISO 9409-1)							E
配合销孔 x 深度	Dowel hole x depth	D15	H7	5x6	6x7	6x7		
数量 x 螺纹 x 深度	Number x thread x depth	G2		7 x M5x7	7 x M6x10	11 x M6x12		

⁽²⁾ 所有的尺寸单位为mm

⁽³⁾ 减速机级数

⁽²⁾ Dimensions in mm

⁽³⁾ Number of stages

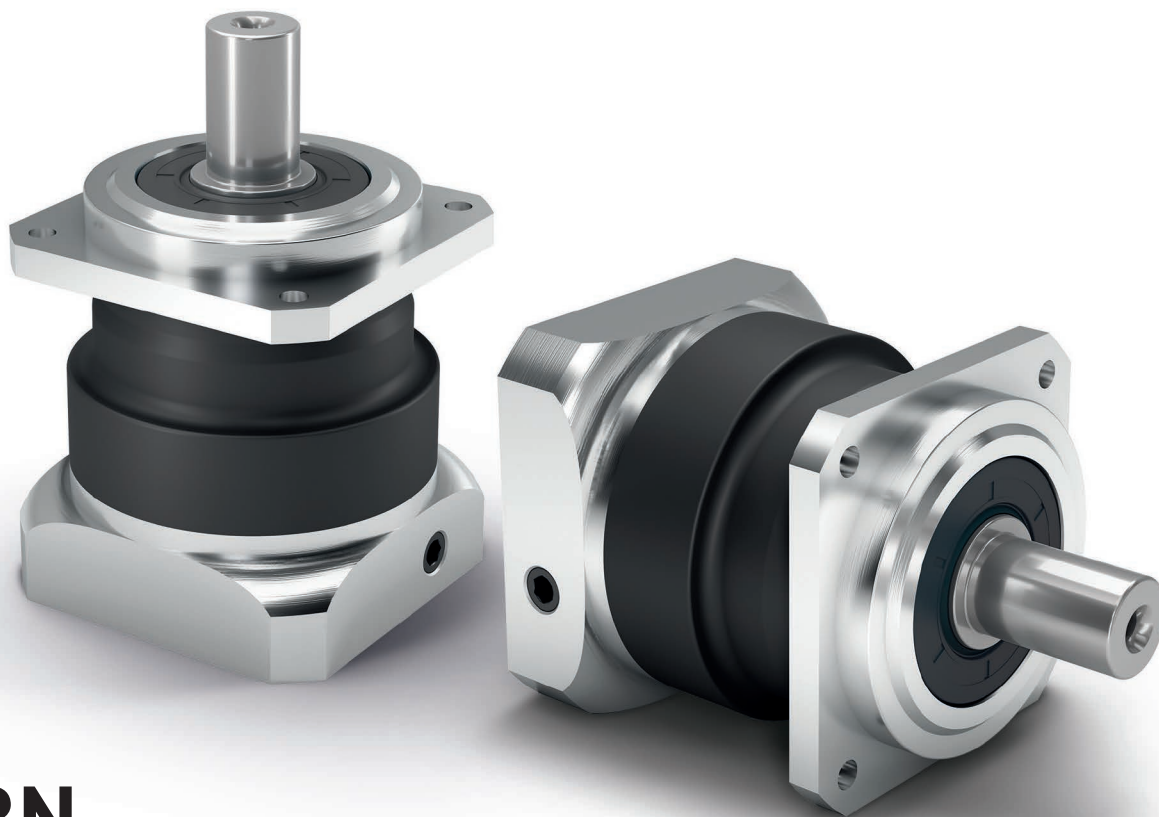

PSBN

高性能精密减速机 配有高精度斜齿 驱动运行时安静无噪音

我们的 **PSBN** 是高精度行星减速机与高效率轴承技术的理想组合。它是我们为了让电机在高转速下达到最高性能而专门研发的产品。它凭借斜齿设计可以特别平稳地运行 —— 而且噪音低于多数产品。

The high-performance precision planetary gearbox with helical gearing for a particularly quiet drive

Our **PSBN** is the ideal combination of a precision planetary gearbox and efficient bearing technology. It was designed specifically to achieve maximum performance at high speed. Thanks to the helical gearing, it operates particularly smoothly - and is quieter than average.

额定扭矩
Nominal output torque **11 - 470 Nm**

径向力
Radial force **640 - 5800 N**

轴向力
Axial force **1100 - 9400 N**

回程间隙
Torsional backlash **1 - 8 arcmin**

防护等级
Protection class **IP65**

结构尺寸
Frame sizes

- 55
- 70
- 90
- 115
- 142

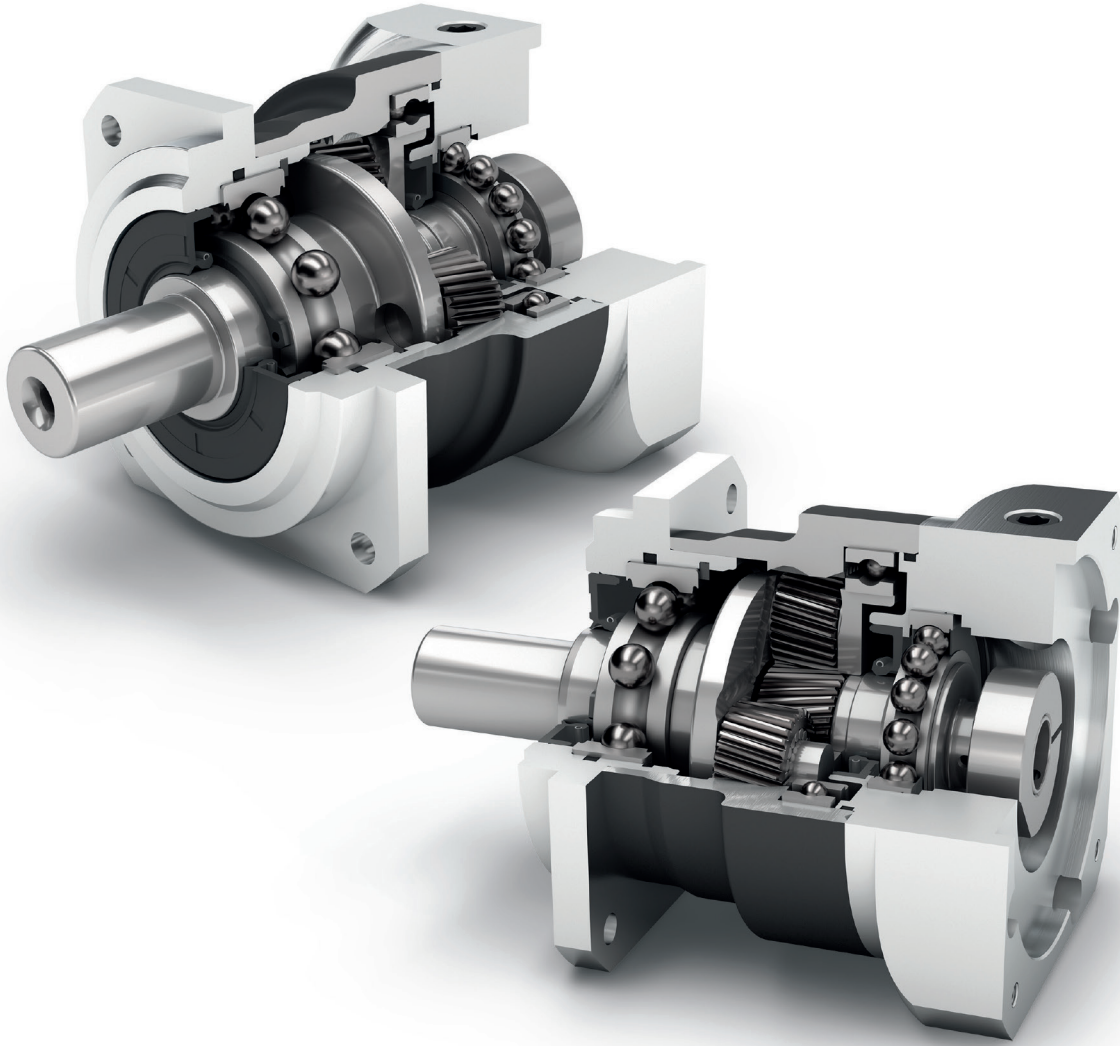

精密型
Precision Line



旋转方向 同方向
Equidirectional rotation



正方形输出法兰
Square type output flange



径向轴密封
Rotary shaft seal



可选：降低回程间隙
Option: Reduced backlash



同轴减速机
Coaxial gearbox



斜齿
Helical gear



增强深沟球轴承
Reinforced deep groove ball bearings



行星齿轮架（笼状结构）
Planet carrier in cage design



可选：喷漆表面
——RAL 9005 黑色
Option: Painted surface
- RAL 9005 Jet black

技术特点的详细解释，请从第173页读起。
Detailed explanations of the technical features starting on page 173.

Code	减速机参数	Gearbox characteristics			PSBN055	PSBN070	PSBN090	PSBN115	PSBN142	p ⁽¹⁾
	使用寿命 (L _{10h})	Service life (L _{10h})	t _L	h	20.000					
	T _{2N} × 0,88 时的使用寿命	Service life at T _{2N} × 0,88			30.000					
	满载时效率 ⁽²⁾	Efficiency at full load ⁽²⁾	η	%	98					1
	最低工作温度	Min. operating temperature	T _{min}	°C	-25					
	最高工作温度	Max. operating temperature	T _{max}		90					
	防护等级	Protection class	IP65							
S	标准润滑	Standard lubrication	润滑油(终生润滑) / Oil (lifetime lubrication)							
F	食品级润滑	Food grade lubrication	润滑油(终生润滑) / Oil (lifetime lubrication)							
L	低温润滑 ⁽³⁾	Low temperature lubrication ⁽³⁾	润滑油(终生润滑) / Oil (lifetime lubrication)							
	安装位置	Installation position	任意 / Any							
S	标准回程间隙	Standard backlash	j _t	arcmin	< 6	< 3	< 3	< 3	< 3	1
					< 8	< 5	< 5	< 5	< 5	2
R	降低回程间隙	Reduced backlash			< 4	< 2	< 1	< 1	< 1	1
					< 6	< 2	< 1	< 1	< 1	2
	抗扭刚度 ⁽²⁾	Torsional stiffness ⁽²⁾	c _g	Nm / arcmin	1,4 - 2,3	4,1 - 5,4	9,3 - 12,8	22,5 - 32,5	59,5 - 76,0	1
					1,5 - 2,4	4,1 - 5,7	10,2 - 13,4	25,5 - 35,0	57,5 - 71,0	2
	减速机重量 ⁽²⁾	Gearbox weight ⁽²⁾	m _G	kg	0,8	1,4 - 1,5	2,7 - 2,8	5,4 - 5,7	13,2 - 13,5	1
					1,1	2,0 - 2,1	3,3 - 3,4	6,5 - 6,7	14,8 - 15,2	2
S	标准的箱体表面	Standard surface	箱体:钢 - 热处理后氧化 (黑色) Housing: Steel - heat-treated and post-oxidized (black)							
B	喷漆表面	Painted surface	RAL 9005 黑色 RAL 9005 Jet black							
	运行噪音 ⁽⁴⁾	Running noise ⁽⁴⁾	Q _g	dB(A)	56	57	58	63	66	
	基于减速机输入法兰的最大弯矩 ⁽⁵⁾	Max. bending moment based on the gearbox input flange ⁽⁵⁾	M _b	Nm	10	18	38	80	180	1
					10	18	18	38	80	2

输出轴载荷	Output shaft loads			PSBN055	PSBN070	PSBN090	PSBN115	PSBN142	p ⁽¹⁾
20,000 h 径向力 ⁽⁶⁾⁽⁷⁾	Radial force for 20,000 h ⁽⁶⁾⁽⁷⁾	F _{r,20.000 h}	N	640	1000	1900	2300	4200 - 5800	
20,000 h 轴向力 ⁽⁶⁾⁽⁷⁾	Axial force for 20,000 h ⁽⁶⁾⁽⁷⁾	F _{a,20.000 h}		1100	1500	3000	4400	9400	
30,000 h 径向力 ⁽⁶⁾⁽⁷⁾	Radial force for 30,000 h ⁽⁶⁾⁽⁷⁾	F _{r,30.000 h}		560	850	1700	2000	3700 - 5100	
30,000 h 轴向力 ⁽⁶⁾⁽⁷⁾	Axial force for 30,000 h ⁽⁶⁾⁽⁷⁾	F _{a,30.000 h}		900	1300	2500	3700	7700	
最大径向力 ⁽⁷⁾⁽⁸⁾	Maximum radial force ⁽⁷⁾⁽⁸⁾	F _{r,Stat}		830	1600	3100	4500	9500	
最大轴向力 ⁽⁷⁾⁽⁸⁾	Maximum axial force ⁽⁷⁾⁽⁸⁾	F _{a,Stat}		1350	1500	2800	4500	9600	
20,000 h 倾斜力矩 ⁽⁶⁾⁽⁸⁾	Tilting moment for 20,000 h ⁽⁶⁾⁽⁸⁾	M _{K,20.000 h}	Nm	33	68	154	226	581 - 811	
30,000 h 倾斜力矩 ⁽⁶⁾⁽⁸⁾	Tilting moment for 30,000 h ⁽⁶⁾⁽⁸⁾	M _{K,30.000 h}		28	58	138	197	512 - 697	

转动惯量	Moment of inertia			PSBN055	PSBN070	PSBN090	PSBN115	PSBN142	p ⁽¹⁾
转动惯量 ⁽²⁾	Mass moment of inertia ⁽²⁾	J	kgcm ²	0,096	0,127	0,327	0,874	6,539	1
				-	-	-	-	-	
				0,133	0,260	0,785	2,650	14,440	2
				0,096	0,123	0,124	0,321	0,841	
				-	-	-	-	2,003	

(1) 减速机级数 (1) Number of stages
 (2) 传动比相关的数值可在 Tec Data Finder 中检索 - www.neugart.com (2) The ratio-dependent values can be retrieved in Tec Data Finder - www.neugart.com
 (3) T_{min} = -40°C. 理想运行温度最高为 50°C (3) T_{min} = -40°C. Optimal operating temperature max. 50°C
 (4) 距离减速机 1 m 时; 在输入转速为 n₁=3000 min⁻¹ 且无负荷时测得; i=5 (4) Sound pressure level from 1 m, measured on input running at n₁=3000 rpm no load; i=5
 (5) 最大电机重量* (单位: kg) = 0.2 × M_b / 电机长度 (单位: m) (5) Max. motor weight* in kg = 0.2 × M_b / motor length in m
 * 电机重量对称分布 * with symmetrically distributed motor weight
 * 水平和固定的安装位置 * with horizontal and stationary mounting
 (6) 数据以 n₂=100 min⁻¹ 的输出轴转速为准 (6) These values are based on an output shaft speed of n₂=100 rpm
 (7) 以输出轴中心为准 (7) Based on center of output shaft
 (8) 更改 T_{2N}, F_r, F_a 以及周期和轴承使用寿命时, 数值存在偏差(部分较高)。 (8) Other (sometimes higher) values following changes to T_{2N}, F_r, F_a, cycle, and service life of bearing. Application specific configuration with NCP - www.neugart.com
 利用 NCP 针对应用进行专门设计 - www.neugart.com

输出扭矩	Output torques			PSBN055	PSBN070	PSBN090	PSBN115	PSBN142	i ⁽¹⁾	p ⁽²⁾
额定输出扭矩 ⁽³⁾⁽⁴⁾	Nominal output torque ⁽³⁾⁽⁴⁾	T _{2N}	Nm	11	29	54	135	380	3	1
				18	39	80	180	470	4	
				18	40	80	175	405	5	
				18	37	78	175	355	7	
				18	39	75	155	350	8	
				13,5	28	59	140	305	10	
				16	29	54	135	380	12	2
				18	29	54	135	380	15	
				18	39	80	180	450	16	
				18	39	80	180	450	20	
				18	40	80	175	405	25	
				18	40	80	175	405	35	
				18	39	80	180	470	40	
				18	40	80	175	405	50	
				18	37	78	175	355	70	
				13,5	28	59	140	305	100	
最大输出扭矩 ⁽⁴⁾⁽⁵⁾	Max. output torque ⁽⁴⁾⁽⁵⁾	T _{2max}	Nm	18	46	86	216	608	3	1
				29	62	128	288	752	4	
				29	64	128	280	648	5	
				29	59	125	280	568	7	
				29	62	120	248	560	8	
				22	45	94	224	488	10	
				26	46	86	216	608	12	2
				29	46	86	216	608	15	
				29	62	128	288	720	16	
				29	62	128	288	720	20	
				29	64	128	280	648	25	
				29	64	128	280	648	35	
				29	62	128	288	752	40	
				29	64	128	280	648	50	
				29	59	125	280	568	70	
				22	45	94	224	488	100	

PSBN

⁽¹⁾ 传动比 (i=n₁/n₂)

⁽²⁾ 减速机级数

⁽³⁾ 利用 NCP 针对应用进行专门设计 – www.neugart.com

⁽⁴⁾ 平键 (代码 „A”)时的数值: 针对交变载荷

⁽⁵⁾ 允许输出轴转动30.000转; 参见第 166 页

⁽¹⁾ Ratios (i=n₁/n₂)

⁽²⁾ Number of stages

⁽³⁾ Application specific configuration with NCP – www.neugart.com

⁽⁴⁾ Values for feather key (code "A"): for repeated load

⁽⁵⁾ 30,000 rotations of the output shaft permitted; see page 167

输出扭矩	Output torques			PSBN055	PSBN070	PSBN090	PSBN115	PSBN142	i ⁽¹⁾	p ⁽²⁾
急停扭矩 ⁽³⁾	Emergency stop torque ⁽³⁾	T _{2Stop}	Nm	48	90	210	490	1250	3	1
				48	120	280	650	1650	4	
				48	130	280	650	1650	5	
				48	80	175	340	1300	7	
				48	90	200	380	1100	8	
				24	90	200	480	600	10	
			48	135	220	500	1250	12	2	
			48	135	220	500	1250	15		
			48	150	300	650	1650	16		
			48	150	300	650	1650	20		
			48	150	300	650	1650	25		
			48	150	300	650	1650	35		
			48	150	300	650	1650	40		
			48	150	300	650	1650	50		
			48	80	175	340	1300	70		
			24	80	200	480	600	100		

输入转速	Input speeds			PSBN055	PSBN070	PSBN090	PSBN115	PSBN142	i ⁽¹⁾	p ⁽²⁾
T _{2N} 和 S1 时的平均热输入转速 ⁽⁴⁾⁽⁵⁾	Average thermal input speed at T _{2N} and S1 ⁽⁴⁾⁽⁵⁾	n _{1N}	min ⁻¹	4950 ⁽⁶⁾	3800 ⁽⁶⁾	3400 ⁽⁶⁾	2900 ⁽⁶⁾	1600 ⁽⁶⁾	3	1
				5000 ⁽⁶⁾	4400 ⁽⁶⁾	3700 ⁽⁶⁾	3000 ⁽⁶⁾	1950 ⁽⁶⁾	4	
				5000 ⁽⁶⁾	4600 ⁽⁶⁾	3900 ⁽⁶⁾	3500 ⁽⁶⁾	2350 ⁽⁶⁾	5	
				5000	5000	4500	4000 ⁽⁶⁾	3150 ⁽⁶⁾	7	
				5000	5000	4500	4000	3450 ⁽⁶⁾	8	
				5000	5000	4500	4000	3500	10	
				4950 ⁽⁶⁾	5000	5000	4500	3150 ⁽⁶⁾	12	2
				5000 ⁽⁶⁾	5000	5000	4500	3950 ⁽⁶⁾	15	
				5000 ⁽⁶⁾	5000	5000	4500	3400 ⁽⁶⁾	16	
				5000	5000	5000	4500	4000 ⁽⁶⁾	20	
				5000	5000	5000	4500	4000	25	
				5000	5000	5000	4500	4000	35	
				5000	5000	5000	4500	4000	40	
				5000	5000	5000	4500	4000	50	
				5000	5000	5000	4500	4000	70	
				5000	5000	5000	4500	4000	100	
最高机械输入转速 ⁽⁴⁾	Max. mechanical input speed ⁽⁴⁾	n _{1Limit}	min ⁻¹	10000	14000	10000	8500	6500		1
				10000	14000	14000	10000	8500		2

⁽¹⁾ 传动比 (i=n₁/n₂)

⁽²⁾ 减速级数

⁽³⁾ 允许 1000 次

⁽⁴⁾ 利用 NCP 针对应用设计转速 – www.neugart.com

⁽⁵⁾ 定义请参见第 166 页

⁽⁶⁾ 在 50% T_{2N} 输出和 S1 模式下的平均热输入转速

⁽¹⁾ Ratios (i=n₁/n₂)

⁽²⁾ Number of stages

⁽³⁾ Permitted 1000 times

⁽⁴⁾ Application-specific speed configurations with NCP – www.neugart.com

⁽⁵⁾ See page 167 for the definition

⁽⁶⁾ Average thermal input speed at 50% T_{2N} and S1

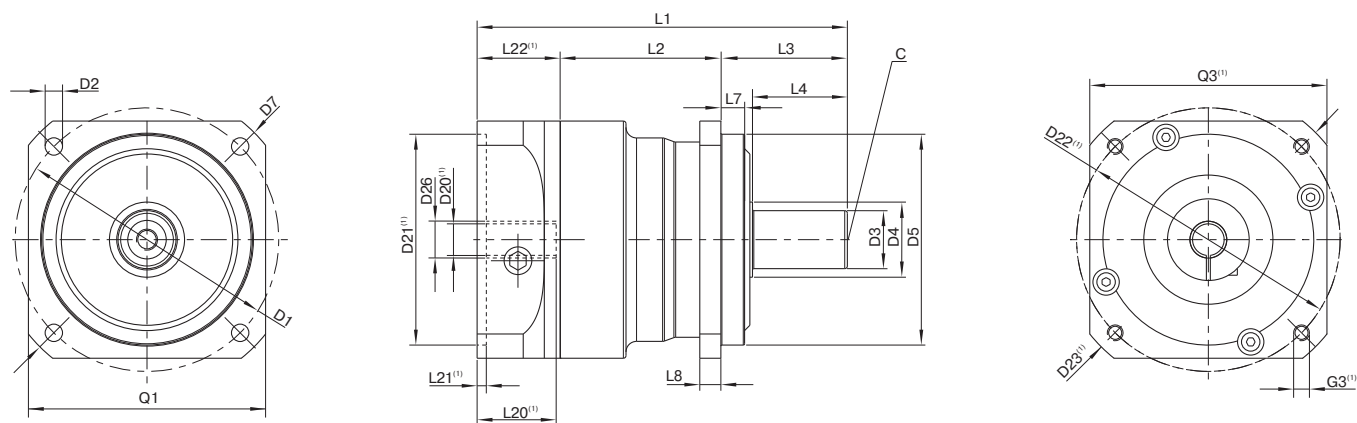

图示为带平键的 PSBN090 / 1 级 / 光滑输出轴 / 14 mm 锁紧系统 / 适配电机法兰 - 2 件式 - 圆形通用法兰 / B5 电机法兰类型
 Drawing corresponds to a PSBN090 / 1-stage / smooth output shaft / 14 mm clamping system / motor adaptation - 2-part - round universal flange / B5 flange type motor

⁽¹⁾ 具体尺寸视电机/减速机法兰而定。可以在 www.neugart.com 下 Tec Data Finder 中针对每个电机适配电机特有的输入法兰几何尺寸。
⁽²⁾ The dimensions vary with the motor/gearbox flange. The input flange dimensions can be retrieved for each specific motor in Tec Data Finder at www.neugart.com

Geometrie ⁽¹⁾	Geometry ⁽¹⁾			PSBN055	PSBN070	PSBN090	PSBN115	PSBN142	p ⁽²⁾	Code
输出端安装孔节圆直径	Pitch circle diameter output	D1		63	70	100	130	165		
输出端安装孔直径	Mounting bore output	D2	4x	5,5	5,5	6,6	9,0	11,0		
输出轴直径	Shaft diameter output	D3	j6	13	16	22	32	40		
输出轴轴肩直径	Shaft collar output	D4		17	25	28,5	38,5	48,5		
输出端定位凸台直径	Centering Ø output	D5	g6	50	50	80	110	130		
输出法兰对角线尺寸	Diagonal dimension output	D7		74	80	115	148	185		
输出端法兰外方	Flange cross section output	Q1	■	55	60	90	115	140		
最小总长	Min. total length	L1		93,5	116,5	140,5	182,5	247,5	1	
				117	145	162,5	204	279	2	
箱体长度	Housing length	L2		43	54	61	74	100,5	1	
				56,5	82,5	89	107,5	138,5	2	
输出轴轴长	Shaft length output	L3		26	37	48	65	97		
输出端定位凸台深度	Centering depth output	L7		6	6	9	4	12		
输出端法兰厚度	Flange thickness output	L8		6	6	8	10	12		
中心孔 (DIN 332, DR 形)	Center hole (DIN 332, type DR)	C		M4x10	M5x12,5	M8x19	M12x28	M16x36		
电机轴直径j6/k6	Motor shaft diameter j6/k6	D20		更多信息见第 163/164 页 More information on page 163/164						
输入端锁紧系统直径	Clamping system diameter input	D26		更多信息见第 163/164 页 More information on page 163/164						
带平键的输出轴 (DIN 6885-1)	Output shaft with feather key (DIN 6885-1)			A 5x5x16	A 5x5x25	A 6x6x28	A 10x8x50	A 12x8x65		
平键宽度 (DIN 6885-1)	Feather key width (DIN 6885-1)	B1		5	5	6	10	12		A
含平键在内的轴高 (DIN 6885-1)	Shaft height including feather key (DIN 6885-1)	H1		15	18	24,5	35	43		
到轴肩的距离	Shaft length from shoulder	L4		19	28	36	58	82		
平键长度	Feather key length	L5		16	25	28	50	65		
到轴端的距离	Distance from shaft end	L6		2	2	4	4	8		
光滑输出轴	Smooth output shaft									
到轴肩的距离	Shaft length from shoulder	L4		19	28	36	58	82		B

⁽¹⁾ 所有的尺寸单位为mm
⁽²⁾ 减速机级数

⁽¹⁾ Dimensions in mm
⁽²⁾ Number of stages

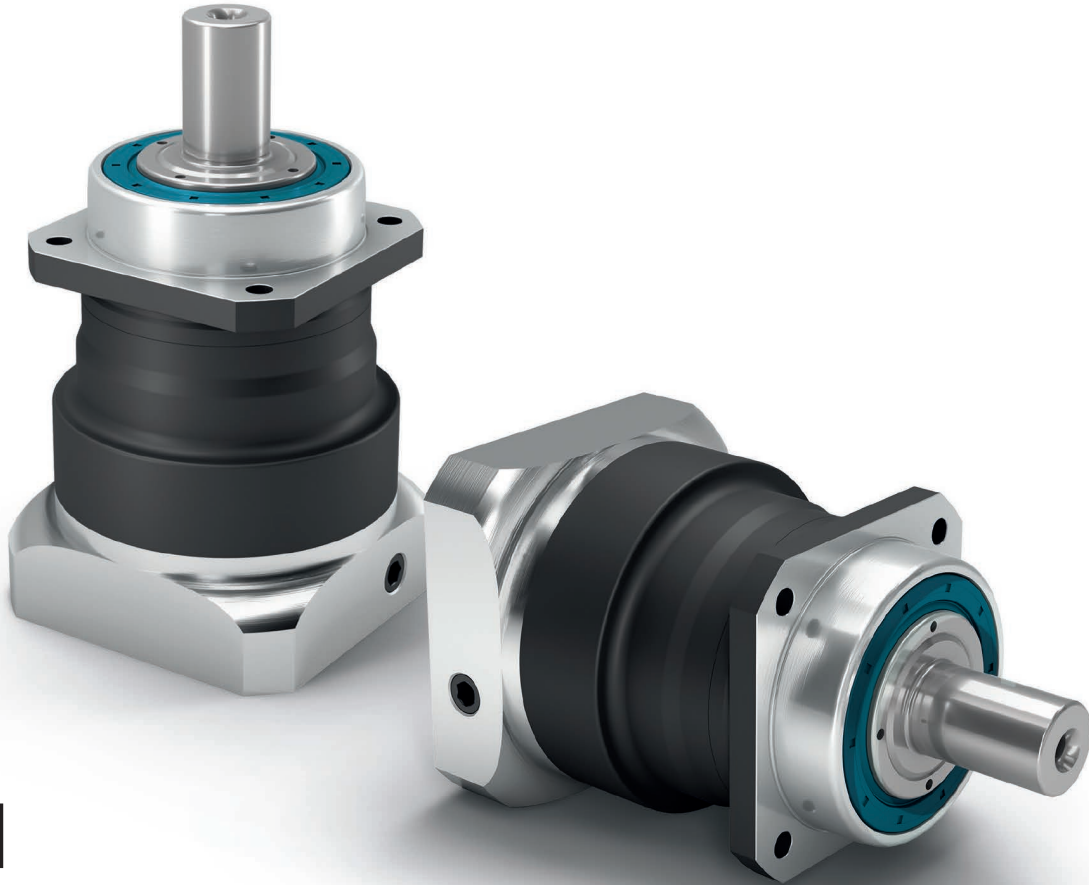

PSN

斜齿高精度减速机能够实现噪音极低的同步运行，轴承负载能力强

我们的 **PSN** 是纯粹的进步：它的斜齿确保了低噪音级别的同步。高精度行星减速机将振动降低至最小。**PSN** 在承受极高负荷的情况下仍然保持高精度，这使其成为全世界性能最强大的减速机之一。

The helical precision planetary gearbox for low-noise operation and high bearing loads

Our **PSN** is pure progress: Its helical gearing ensures low-noise synchronization. With this precision planetary gearbox, vibrations are reduced to a minimum. Precision even under very high loads makes the **PSN** one of the most high-performance gearboxes in the world.

额定扭矩
Nominal output torque **11 - 950 Nm**

径向力
Radial force **950 - 20000 N**

轴向力
Axial force **2200 - 19000 N**

回程间隙
Torsional backlash **1 - 8 arcmin**

防护等级
Protection class **IP65**

结构尺寸
Frame sizes

- 55
- 70
- 90
- 115
- 142
- 190

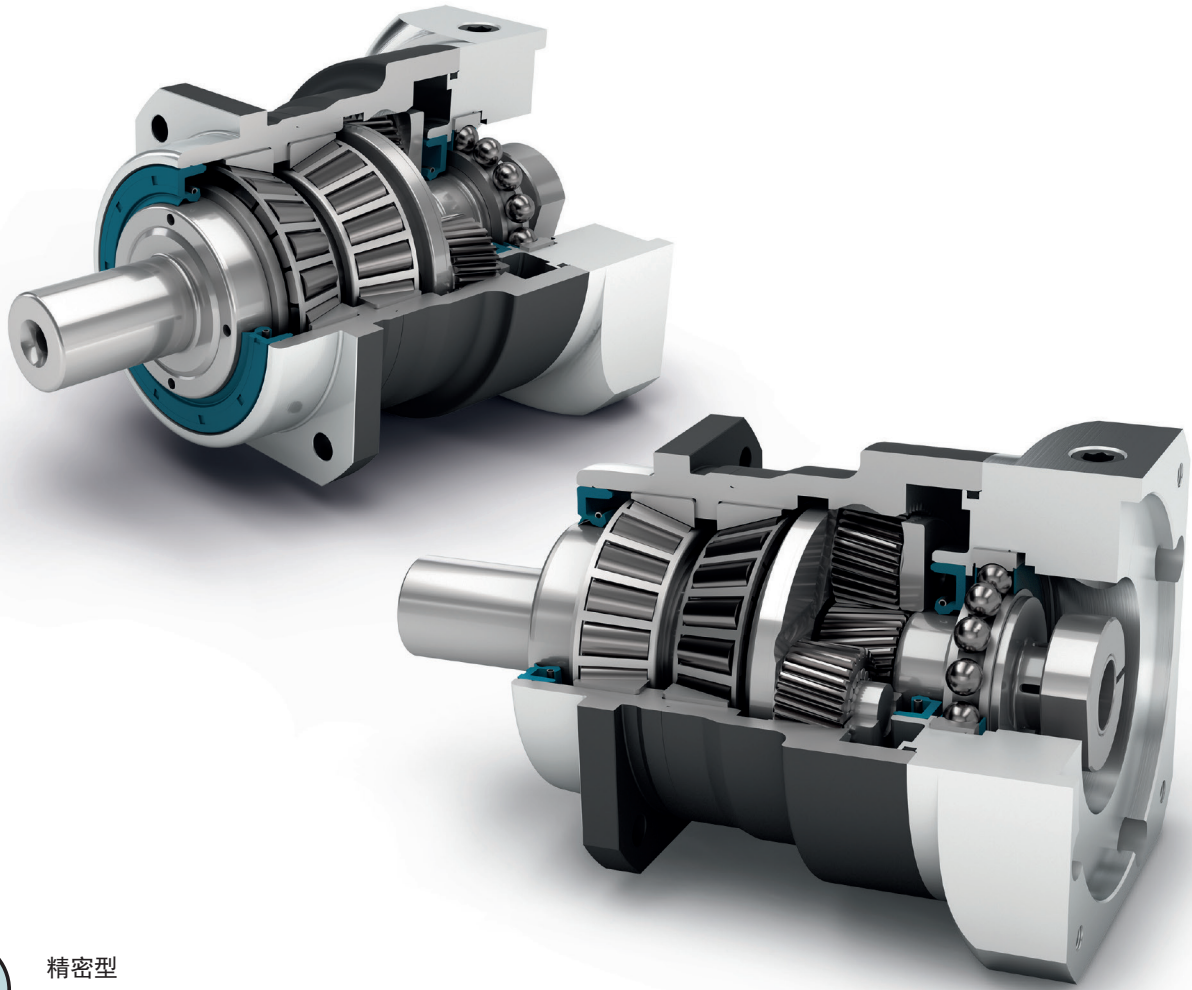

精密型
Precision Line



同轴减速机
Coaxial gearbox



斜齿
Helical gear



配有预紧的圆锥滚子轴承
Preloaded tapered roller bearings



输出端带有超长定心环
Extra long centering collar



可选: 降低回程间隙
Option: Reduced backlash



可选: 装有小齿轮的高精度减速机
132页
Option: Planetary gearbox with
mounted pinion on page 132



旋转方向 同方向
Equidirectional rotation



正方形输出法兰
Square type output flange



径向轴密封
Rotary shaft seal



行星齿轮架 (笼状结构)
Planet carrier in cage design



可选: 花键输出轴 (DIN 5480)
Option: Splined output shaft (DIN 5480)



可选: 喷漆表面
——RAL 9005 黑色
Option: Painted surface
– RAL 9005 Jet black

技术特点的详细解释, 请从第173页读起。
Detailed explanations of the technical features starting on page 173.

Code	减速机参数	Gearbox characteristics			PSN055	PSN070	PSN090	PSN115	PSN142	PSN190	p ⁽¹⁾	
	使用寿命 (L _{10h})	Service life (L _{10h})	t _L	h	20.000							
	T _{2N} × 0,88 时的使用寿命	Service life at T _{2N} × 0,88			30.000							
	满载时效率 ⁽²⁾	Efficiency at full load ⁽²⁾	η	%	98						1	
	最低工作温度	Min. operating temperature	T _{min}	°C	-25							
	最高工作温度	Max. operating temperature	T _{max}		90							
	防护等级	Protection class	IP65									
S	标准润滑	Standard lubrication	润滑油(终生润滑) / Oil (lifetime lubrication)									
F	食品级润滑	Food grade lubrication	润滑油(终生润滑) / Oil (lifetime lubrication)									
L	低温润滑 ⁽³⁾	Low temperature lubrication ⁽³⁾	润滑油(终生润滑) / Oil (lifetime lubrication)									
	安装位置	Installation position	任意 / Any									
S	标准回程间隙	Standard backlash	j _t	arcmin	< 6	< 3	< 3	< 3	< 3	< 3	1	
					< 8	< 5	< 5	< 5	< 5	< 5	< 5	2
R	降低回程间隙	Reduced backlash			< 4	< 2	< 1	< 1	< 1	< 1	< 1	1
					< 6	< 2	< 1	< 1	< 1	< 1	< 1	2
	抗扭刚度 ⁽²⁾	Torsional stiffness ⁽²⁾	c _g	Nm / arcmin	1,3 - 1,9	3,6 - 4,8	9,2	22,0	62,0	181,0	1	
					13,0	34,5	88,0	246,0				
					1,3 - 1,9	3,6 - 5,0	10,2	28,0	61,0	179,0	2	
					13,8	39,5	85,0	255,0				
	减速机重量 ⁽²⁾	Gearbox weight ⁽²⁾	m _G	kg	0,8	1,9 - 2,0	3,4 - 3,5	6,7	15,1	34,5	1	
					7,0	15,5	36,3					
					1,1	2,6	3,9 - 4,0	7,8	16,5	38,6	2	
					8,0	17,0	40,5					
S	标准的箱体表面	Standard surface	箱体: 钢 - 热处理后氧化 (黑色) Housing: Steel - heat-treated and post-oxidized (black)									
B	喷漆表面	Painted surface	RAL 9005 黑色 RAL 9005 Jet black									
	运行噪音 ⁽⁴⁾	Running noise ⁽⁴⁾	Q _G	dB(A)	56	57	58	63	66	68		
	基于减速机输入法兰的最大弯矩 ⁽⁵⁾	Max. bending moment based on the gearbox input flange ⁽⁵⁾	M _b	Nm	10	18	38	80	180	300	1	
					10	18	18	38	80	180	180	2

输出轴载荷	Output shaft loads			PSN055	PSN070	PSN090	PSN115	PSN142	PSN190	p ⁽¹⁾
20,000 h 径向力 ⁽⁶⁾⁽⁷⁾	Radial force for 20,000 h ⁽⁶⁾⁽⁷⁾	F _{r20.000h}	N	950	3200	5500	6000	13000	20000	
20,000 h 轴向力 ⁽⁶⁾⁽⁷⁾	Axial force for 20,000 h ⁽⁶⁾⁽⁷⁾	F _{a20.000h}		2200	4400	6400	8000	15000	19000	
30,000 h 径向力 ⁽⁶⁾⁽⁷⁾	Radial force for 30,000 h ⁽⁶⁾⁽⁷⁾	F _{r30.000h}		830	3200	4800	5400	11500	17500	
30,000 h 轴向力 ⁽⁶⁾⁽⁷⁾	Axial force for 30,000 h ⁽⁶⁾⁽⁷⁾	F _{a30.000h}		2200	3900	5700	7000	13500	18500	
最大径向力 ⁽⁷⁾⁽⁸⁾	Maximum radial force ⁽⁷⁾⁽⁸⁾	F _{r Stat}		950	3200	5500	6000	13000	20000	
最大轴向力 ⁽⁷⁾⁽⁸⁾	Maximum axial force ⁽⁷⁾⁽⁸⁾	F _{a Stat}		2200	4400	6400	8000	15000	19000	
20,000 h 倾斜力矩 ⁽⁶⁾⁽⁸⁾	Tilting moment for 20,000 h ⁽⁶⁾⁽⁸⁾	M _{K20.000h}	Nm	40	203	419	562	1566	2887	
30,000 h 倾斜力矩 ⁽⁶⁾⁽⁸⁾	Tilting moment for 30,000 h ⁽⁶⁾⁽⁸⁾	M _{K30.000h}		35	203	366	506	1385	2526	

转动惯量	Moment of inertia			PSN055	PSN070	PSN090	PSN115	PSN142	PSN190	p ⁽¹⁾
转动惯量 ⁽²⁾	Mass moment of inertia ⁽²⁾	J	kgcm ²	0,096	0,128	0,330	0,857	6,475	21,695	1
				0,126	0,272	0,811	2,484	13,112	53,182	
				0,095	0,123	0,124	0,321	0,840	6,360	2
				0,109	0,177	0,204	0,600	1,962	10,654	

(1) 减速机级数
 (2) 传动比相关的数值可在 Tec Data Finder 中检索 - www.neugart.com
 (3) T_{min} = -40°C. 理想运行温度最高为 50°C
 (4) 距离减速机 1 m 时; 在输入转速为 n₁=3000 min⁻¹ 且无负荷时测得; i=5
 (5) 最大电机重量* (单位: kg) = 0.2 × M_b / 电机长度 (单位: m)
 * 电机重量对称分布
 * 水平和固定的安装位置
 (6) 数据以 n₂=100 min⁻¹ 的输出轴转速为准。
 (7) 以输出轴中心为准
 (8) 更改 T_{2N}, F_r, F_a 以及周期和轴承使用寿命时, 数值存在偏差(部分较高)。利用 NCP 针对应用进行专门设计 - www.neugart.com

(1) Number of stages
 (2) The ratio-dependent values can be retrieved in Tec Data Finder - www.neugart.com
 (3) T_{min} = -40°C. Optimal operating temperature max. 50°C
 (4) Sound pressure level from 1 m, measured on input running at n₁=3000 rpm no load; i=5
 (5) Max. motor weight* in kg = 0.2 × M_b / motor length in m
 * with symmetrically distributed motor weight
 * with horizontal and stationary mounting
 (6) These values are based on an output shaft speed of n₂=100 rpm
 (7) Based on center of output shaft
 (8) Other (sometimes higher) values following changes to T_{2N}, F_r, F_a, cycle, and service life of bearing. Application specific configuration with NCP - www.neugart.com

输出扭矩	Output torques			PSN055	PSN070	PSN090	PSN115	PSN142	PSN190	i ⁽¹⁾	p ⁽²⁾
额定输出扭矩 ⁽³⁾⁽⁴⁾	Nominal output torque ⁽³⁾⁽⁴⁾	T _{2N}	Nm	11	29	54	135	380	845	3	1
				18	39	80	180	470	950	4	
				18	40	80	175	405	950	5	
				18	37	78	175	355	900	7	
				18	39	75	155	350	-	8	
				13,5	28	59	140	305	750	10	2
				16	29	54	135	380	845	12	
				18	29	54	135	380	845	15	
				18	39	80	180	450	950	16	
				18	39	80	180	450	950	20	
				18	40	80	175	405	950	25	
				18	40	80	175	405	950	35	
				18	39	80	180	470	950	40	
				18	40	80	175	405	950	50	
18	37	78	175	355	900	70					
13,5	28	59	140	305	750	100					
最大输出扭矩 ⁽⁴⁾⁽⁵⁾	Max. output torque ⁽⁴⁾⁽⁵⁾	T _{2max}	Nm	18	46	86	216	608	1352	3	1
				29	62	128	288	752	1520	4	
				29	64	128	280	648	1520	5	
				29	59	125	280	568	1440	7	
				29	62	120	248	560	-	8	
				22	45	94	224	488	1200	10	2
				26	46	86	216	608	1352	12	
				29	46	86	216	608	1352	15	
				29	62	128	288	720	1520	16	
				29	62	128	288	720	1520	20	
				29	64	128	280	648	1520	25	
				29	64	128	280	648	1520	35	
				29	62	128	288	752	1520	40	
				29	64	128	280	648	1520	50	
29	59	125	280	568	1440	70					
22	45	94	224	488	1200	100					

PSN

⁽¹⁾ 传动比 (i=n₁/n₂)

⁽²⁾ 减速机级数

⁽³⁾ 利用 NCP 针对应用进行专门设计 – www.neugart.com

⁽⁴⁾ 平键 (代码 „A”)时的数值: 针对交变载荷

⁽⁵⁾ 允许输出轴转动30.000转; 参见第 166 页

⁽¹⁾ Ratios (i=n₁/n₂)

⁽²⁾ Number of stages

⁽³⁾ Application specific configuration with NCP – www.neugart.com

⁽⁴⁾ Values for feather key (code "A"): for repeated load

⁽⁵⁾ 30,000 rotations of the output shaft permitted; see page 167

输出扭矩	Output torques			PSN055	PSN070	PSN090	PSN115	PSN142	PSN190	i ⁽¹⁾	p ⁽²⁾
急停扭矩 ⁽³⁾	Emergency stop torque ⁽³⁾	T _{2Stop}	Nm	48	90	210	490	1250	2400	3	1
				48	120	280	650	1650	3200	4	
				48	130	280	650	1650	3200	5	
				48	80	175	340	1300	3200	7	
				48	90	200	380	1100	-	8	
				24	90	200	480	600	1700	10	
				48	135	220	500	1250	2400	12	
				48	135	220	500	1250	2400	15	
			2	48	150	300	650	1650	3200	16	
				48	150	300	650	1650	3200	20	
				48	150	300	650	1650	3200	25	
				48	150	300	650	1650	3200	35	
				48	150	300	650	1650	3200	40	
				48	150	300	650	1650	3200	50	
				48	80	175	340	1300	3200	70	
				24	80	200	480	600	1700	100	

输入转速	Input speeds			PSN055	PSN070	PSN090	PSN115	PSN142	PSN190	i ⁽¹⁾	p ⁽²⁾
T _{2N} 和 S1 时的平均热输入转速 ⁽⁴⁾⁽⁵⁾	Average thermal input speed at T _{2N} and S1 ⁽⁴⁾⁽⁵⁾	n _{1N}	min ⁻¹	4700 ⁽⁶⁾	3000 ⁽⁶⁾	2700 ⁽⁶⁾	2000 ⁽⁶⁾	1000 ⁽⁶⁾	750 ⁽⁶⁾	3	1
				5000 ⁽⁶⁾	3700 ⁽⁶⁾	3050 ⁽⁶⁾	2250 ⁽⁶⁾	1250 ⁽⁶⁾	900 ⁽⁶⁾	4	
				5000 ⁽⁶⁾	4400 ⁽⁶⁾	3700 ⁽⁶⁾	2750 ⁽⁶⁾	1550 ⁽⁶⁾	1100 ⁽⁶⁾	5	
				5000	4500	4000	3500 ⁽⁶⁾	2000 ⁽⁶⁾	1450 ⁽⁶⁾	7	
				5000	4500	4000	3500	2200 ⁽⁶⁾	-	8	
				5000	4500	4000	3500	2500 ⁽⁶⁾	1900 ⁽⁶⁾	10	
				2	4600 ⁽⁶⁾	4500	4500	4000 ⁽⁶⁾	2400 ⁽⁶⁾	1550 ⁽⁶⁾	12
					5000 ⁽⁶⁾	4500	4500	4000	3000 ⁽⁶⁾	1900 ⁽⁶⁾	15
					4650 ⁽⁶⁾	4500	4500	4000 ⁽⁶⁾	2600 ⁽⁶⁾	1650 ⁽⁶⁾	16
					5000 ⁽⁶⁾	4500	4500	4000	3250 ⁽⁶⁾	2050 ⁽⁶⁾	20
					5000 ⁽⁶⁾	4500	4500	4000	3500 ⁽⁶⁾	2200 ⁽⁶⁾	25
					5000	4500	4500	4000	3500	2800 ⁽⁶⁾	35
					5000	4500	4500	4000	3500	3000 ⁽⁶⁾	40
					5000	4500	4500	4000	3500	3000	50
					5000	4500	4500	4000	3500	3000	70
					5000	4500	4500	4000	3500	3000	100
最高机械输入转速 ⁽⁴⁾	Max. mechanical input speed ⁽⁴⁾	n _{1Limit}	min ⁻¹	10000	14000	10000	8500	6500	6000		1
				10000	14000	14000	10000	8500	6500		2

⁽¹⁾ 传动比 (i=n₁/n₂)

⁽²⁾ 减速级数

⁽³⁾ 允许 1000 次

⁽⁴⁾ 利用 NCP 针对应用设计转速 - www.neugart.com

⁽⁵⁾ 定义请参见第 166 页

⁽⁶⁾ 在 50% T_{2N} 输出和 S1 模式下的平均热输入转速

⁽¹⁾ Ratios (i=n₁/n₂)

⁽²⁾ Number of stages

⁽³⁾ Permitted 1000 times

⁽⁴⁾ Application-specific speed configurations with NCP - www.neugart.com

⁽⁵⁾ See page 167 for the definition

⁽⁶⁾ Average thermal input speed at 50% T_{2N} and S1

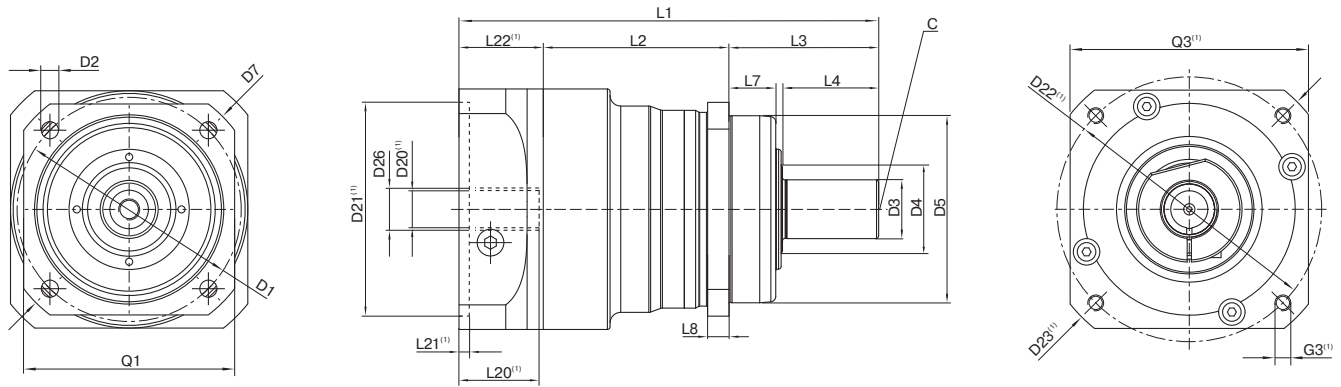

图示为带平键的 PSN090 / 1 级 / 光滑输出轴 / 14 mm 锁紧系统 / 适配电机法兰 – 2 件式 – 圆形通用法兰 / B5 电机法兰类型
 Drawing corresponds to a PSN090 / 1-stage / smooth output shaft / 14 mm clamping system / motor adaptation – 2-part – round universal flange / B5 flange type motor

(1) 具体尺寸视电机/减速机法兰而定。可以在 www.neugart.com 下 Tec Data Finder。中针对每个电机适配电机特有的输入法兰几何尺寸。
 (1) The dimensions vary with the motor/gearbox flange. The input flange dimensions can be retrieved for each specific motor in Tec Data Finder at www.neugart.com

几何尺寸 ⁽¹⁾	Geometry ⁽¹⁾			PSN055	PSN070	PSN090	PSN115	PSN142	PSN190	p ⁽²⁾	Code
输出端安装孔节圆直径	Pitch circle diameter output	D1		63	68 - 75	85	120	165	215		
输出端安装孔直径	Mounting bore output	D2	4x	5,5	5,5	6,5	9,0	11,0	13,5		
输出轴直径	Shaft diameter output	D3	k6	12	16	22	32	40	55		
输出轴轴肩直径	Shaft collar output	D4		16	21,5	31,5	41,5	57,5	76,5		
输出端定位凸台直径	Centering diameter output	D5	g7	50	60	70	90	130	160		
输出法兰对角线尺寸	Diagonal dimension output	D7		74	92	100	140	185	240		
输出端法兰外方	Flange cross section output	Q1	■	55	70	80	110	142	190		
最小总长	Min. total length	L1		103,5	134	157	202,5	261,5	310,5	1	
				127	162,5	179	224,5	292,5	355,5	2	
箱体长度	Housing length	L2		43	60,5	69,5	71	101,5	130,5	1	
				66,5	89	98	104,5	139	194	2	
输出端定位凸台深度	Centering depth output	L7		12	19	17,5	28	28	28		
输出端法兰厚度	Flange thickness output	L8		6	7	8	10	12	15		
中心孔 (DIN 332, DR 形)	Center hole (DIN 332, type DR)	C		M4x10	M5x12,5	M8x19	M12x28	M16x36	M20x42		
电机轴直径j6/k6	Motor shaft diameter j6/k6	D20		更多信息见第 163/164 页 More information on page 163/164							
输入端锁紧系统直径	Clamping system Ø input	D26		更多信息见第 163/164 页 More information on page 163/164							
带平键的输出轴 (DIN 6885-1)	Output shaft with feather key (DIN 6885-1)			A 4x 4x18	A 5x 5x25	A 6x 6x28	A 10x 8x50	A 12x 8x65	A 16x 10x70		A
平键宽度 (DIN 6885-1)	Feather key width (DIN 6885-1)	B1		4	5	6	10	12	16		
含平键在内的轴高 (DIN 6885-1)	Shaft height including feather key (DIN 6885-1)	H1		13,5	18	24,5	35	43	59		
输出轴轴长	Shaft length output	L3		36	48	56	88	110	112		
到轴肩的距离	Shaft length from shoulder	L4		23	28	36	58	80	82		
平键长度	Feather key length	L5		18	25	28	50	65	70		
到轴端的距离	Distance from shaft end	L6		2	2	4	4	8	6		
光滑输出轴	Smooth output shaft										B
输出轴轴长	Shaft length output	L3		36	48	56	88	110	112		
到轴肩的距离	Shaft length from shoulder	L4		23	28	36	58	80	82		
花键输出轴 (DIN 5480)	Splined output shaft (DIN 5480)			-	W16x0,8 x18x6m	W22x1,25 x16x6m	W32x1,25 x24x6m	W40x2,0 x18x6m	W55x2,0 x26x6m		C
花键或键槽的长度	Width of gearing	L _v		-	15	15	15	20	22		
输出轴轴长	Shaft length output	L3		-	46	46	56	70	71,5		
到轴肩的距离	Shaft length from shoulder	L4		-	26	26	26	40	41,5		

⁽¹⁾ 所有的尺寸单位为mm
⁽²⁾ 减速机级数

⁽¹⁾ Dimensions in mm
⁽²⁾ Number of stages

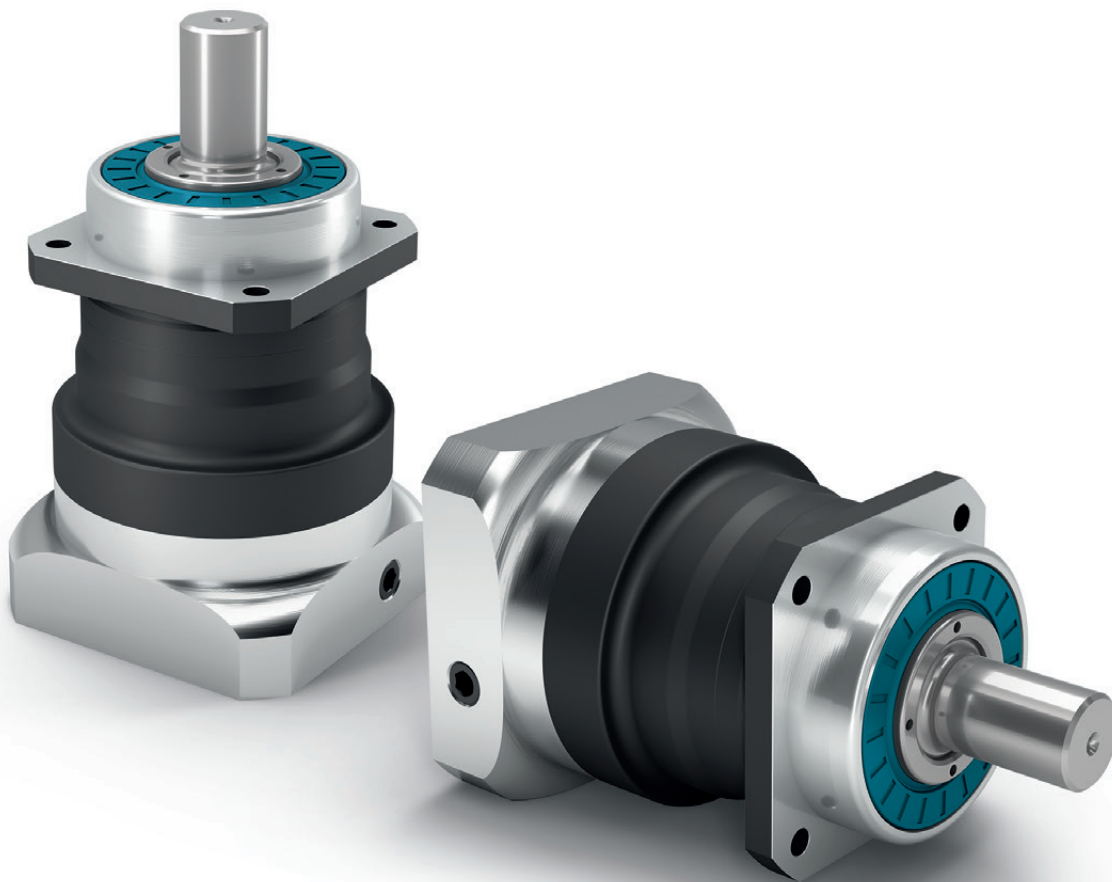

PLN

这款完全密封的直齿行星减速机能够提供极高的效能，且不会损失必要的刚性

我们的直齿高精度行星减速机是针对最高的性能和扭矩设计的。**PLN** 的预胀紧的圆锥滚子轴承和专门调整过的密封确保了在有灰尘和喷淋水的条件下仍然达到最佳性能。

The perfectly sealed planetary gearbox with straight gearing delivers the maximum performance without ever losing the required stiffness

Our precision straight-toothed planetary gearbox is designed for maximum power and torque. The preloaded tapered roller bearings in the **PLN** and the specially matched seal guarantee optimum performance even in applications where dust and water spray are encountered.

额定扭矩
Nominal output torque **27 - 1800 Nm**

径向力
Radial force **3200 - 21000 N**

轴向力
Axial force **4400 - 21000 N**

回程间隙
Torsional backlash **1 - 5 arcmin**

防护等级
Protection class **IP65**

结构尺寸
Frame sizes

- 70
- 90
- 115
- 142
- 190

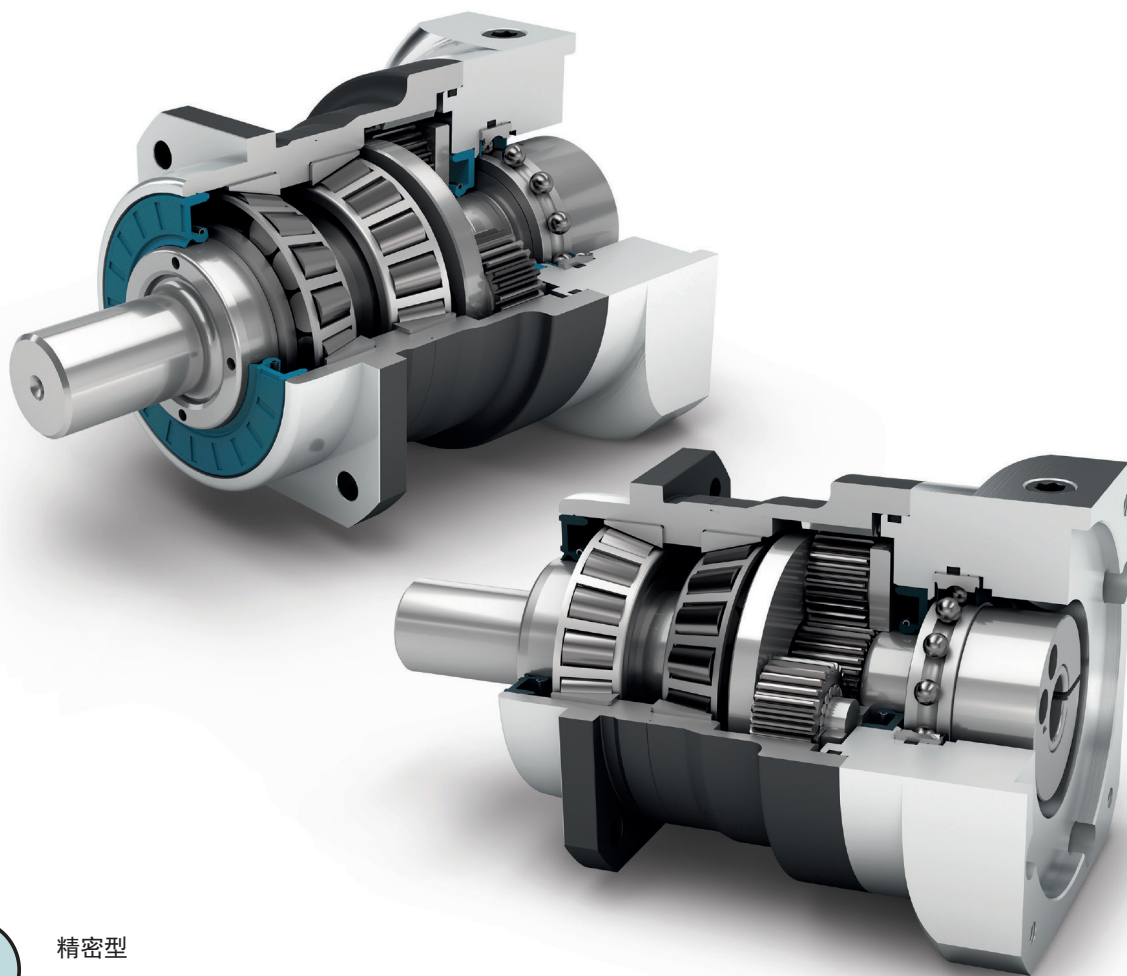

精密型
Precision Line

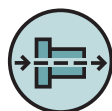

同轴减速机
Coaxial gearbox



直齿
Spur gear



配有预紧的圆锥滚子轴承
Preloaded tapered roller bearings



输出端带有超长定心环
Extra long centering collar



可选: 降低回程间隙
Option: Reduced backlash



可选: 装有小齿轮的高精度减速机
132页
Option: Planetary gearbox with
mounted pinion on page 132



旋转方向 同方向
Equidirectional rotation

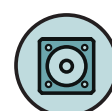

正方形输出法兰
Square type output flange



径向轴密封
Rotary shaft seal



行星齿轮架 (笼状结构)
Planet carrier in cage design



可选: 花键输出轴 (DIN 5480)
Option: Splined output shaft (DIN 5480)



可选: 喷漆表面
——RAL 9005 黑色
Option: Painted surface
– RAL 9005 Jet black

技术特点的详细解释, 请从第173页读起。
Detailed explanations of the technical features starting on page 173.

Code	减速机参数	Gearbox characteristics			PLN070	PLN090	PLN115	PLN142	PLN190	p ⁽¹⁾
	使用寿命 (L _{10h})	Service life (L _{10h})	t _L	h	20.000					
	T _{2N} × 0,88 时的使用寿命	Service life at T _{2N} × 0,88			30.000					
	满载时效率 ⁽²⁾	Efficiency at full load ⁽²⁾	η	%	98					1
					95					2
	最低工作温度	Min. operating temperature	T _{min}	°C	-25					
	最高工作温度	Max. operating temperature	T _{max}		90					
	防护等级	Protection class	IP65							
S	标准润滑	Standard lubrication	润滑油(终生润滑) / Oil (lifetime lubrication)							
F	食品级润滑	Food grade lubrication	润滑油(终生润滑) / Oil (lifetime lubrication)							
L	低温润滑 ⁽³⁾	Low temperature lubrication ⁽³⁾	润滑油(终生润滑) / Oil (lifetime lubrication)							
	安装位置	Installation position	任意 / Any							
S	标准回程间隙	Standard backlash	j _t	arcmin	< 3					1
R	降低回程间隙	Reduced backlash			< 5					2
	抗扭刚度 ⁽²⁾	Torsional stiffness ⁽²⁾	c _g	Nm / arcmin	3,4 - 5,0	9,4 - 12,4	22,0 - 29,0	61,0 - 76,0	155,0 - 218,0	1
					3,4 - 5,0	9,0 - 12,4	22,5 - 29,5	61,0 - 78,0	169,0 - 224,0	2
	减速机重量 ⁽²⁾	Gearbox weight ⁽²⁾	m _G	kg	1,9 - 2,0	3,3 - 3,5	6,4 - 7,2	15,8 - 17,3	32,9 - 41,5	1
					2,4 - 2,5	4,0 - 4,2	8,0 - 8,8	20,8 - 21,5	44,3 - 48,5	2
S	标准的箱体表面	Standard surface	箱体:钢 - 热处理后氧化 (黑色) Housing: Steel - heat-treated and post-oxidized (black)							
B	喷漆表面	Painted surface	RAL 9005 黑色 RAL 9005 Jet black							
	运行噪音 ⁽⁴⁾	Running noise ⁽⁴⁾	Q _G	dB(A)	60	62	65	70	74	
	基于减速机输入法兰的最大弯矩 ⁽⁵⁾	Max. bending moment based on the gearbox input flange ⁽⁵⁾	M _b	Nm	18	38	80	180	300	

输出轴载荷	Output shaft loads			PLN070	PLN090	PLN115	PLN142	PLN190	p ⁽¹⁾
20,000 h 径向力 ⁽⁶⁾⁽⁷⁾	Radial force for 20,000 h ⁽⁶⁾⁽⁷⁾	F _{r20.000h}	N	3200	5500	6000	12500	21000	
20,000 h 轴向力 ⁽⁶⁾⁽⁷⁾	Axial force for 20,000 h ⁽⁶⁾⁽⁷⁾	F _{a20.000h}		4400	6400	8000	15000	21000	
30,000 h 径向力 ⁽⁶⁾⁽⁷⁾	Radial force for 30,000 h ⁽⁶⁾⁽⁷⁾	F _{r30.000h}		3200	4800	5400	11400	18000	
30,000 h 轴向力 ⁽⁶⁾⁽⁷⁾	Axial force for 30,000 h ⁽⁶⁾⁽⁷⁾	F _{a30.000h}		3900	5700	7000	13200	18500	
最大径向力 ⁽⁷⁾⁽⁸⁾	Maximum radial force ⁽⁷⁾⁽⁸⁾	F _{r Stat}		3200	5500	6000	12500	21000	
最大轴向力 ⁽⁷⁾⁽⁸⁾	Maximum axial force ⁽⁷⁾⁽⁸⁾	F _{a Stat}		4400	6400	8000	15000	21000	
20,000 h 倾斜力矩 ⁽⁶⁾⁽⁸⁾	Tilting moment for 20,000 h ⁽⁶⁾⁽⁸⁾	M _{K20.000h}	Nm	191	383	488	1420	2535	
30,000 h 倾斜力矩 ⁽⁶⁾⁽⁸⁾	Tilting moment for 30,000 h ⁽⁶⁾⁽⁸⁾	M _{K30.000h}		191	335	439	1295	2173	

转动惯量	Moment of inertia			PLN070	PLN090	PLN115	PLN142	PLN190	p ⁽¹⁾
转动惯量 ⁽²⁾	Mass moment of inertia ⁽²⁾	J	kgcm ²	0,216	0,560	1,942	7,008	22,876	1
				-	-	-	-	-	
				0,365	1,028	3,256	15,270	63,815	2
				0,209	0,544	1,933	6,811	22,430	
				0,249	-0,699	2,373	9,813	36,003	

(1) 减速机级数
 (2) 传动比相关的数值可在 Tec Data Finder 中检索 - www.neugart.com
 (3) T_{min} = -40°C. 理想运行温度最高为 50°C
 (4) 距离减速机 1 m 时; 在输入转速为 n₁=3000 min⁻¹ 且无负荷时测得; i=5
 (5) 最大电机重量* (单位: kg) = 0.2 × M_b / 电机长度 (单位: m)
 * 电机重量对称分布
 * 水平和固定的安装位置
 (6) 数据以 n₂=100 min⁻¹ 的输出轴转速为准。
 (7) 以输出轴中心为准
 (8) 更改 T_{2N}, F_r, F_a 以及周期和轴承使用寿命时, 数值存在偏差(部分较高)。利用 NCP 针对应用进行专门设计 - www.neugart.com

(1) Number of stages
 (2) The ratio-dependent values can be retrieved in Tec Data Finder - www.neugart.com
 (3) T_{min} = -40°C. Optimal operating temperature max. 50°C
 (4) Sound pressure level from 1 m, measured on input running at n₁=3000 rpm no load; i=5
 (5) Max. motor weight* in kg = 0.2 × M_b / motor length in m
 * with symmetrically distributed motor weight
 * with horizontal and stationary mounting
 (6) These values are based on an output shaft speed of n₂=100 rpm
 (7) Based on center of output shaft
 (8) Other (sometimes higher) values following changes to T_{2N}, F_r, F_a, cycle, and service life of bearing. Application specific configuration with NCP - www.neugart.com

输出扭矩	Output torques			PLN070	PLN090	PLN115	PLN142	PLN190	i ⁽¹⁾	p ⁽²⁾									
额定输出扭矩 ⁽³⁾⁽⁴⁾	Nominal output torque ⁽³⁾⁽⁴⁾	T _{2N}	Nm	45	100	230	450	1000	3	1									
				60	140	300	600	1300	4										
				65	140	260	750	1600	5										
				45	90	180	530	1300	7										
				40	80	150	450	1000	8										
				27	60	125	305	630	10										
				68	110	250	780	1500	12										
				68	110	250	780	1500	15										
		77	150	300	1000	1800	20	2											
									77	150	300	1000	1800	25					
									77	150	300	1000	1800	32					
									65	140	260	900	1800	40					
									40	80	150	450	1000	64					
									27	60	125	305	630	100					
									最大输出扭矩 ⁽⁴⁾⁽⁵⁾	Max. output torque ⁽⁴⁾⁽⁵⁾	T _{2max}	Nm	72	160	368	720	1600	3	1
													96	224	480	960	2080	4	
104	224	416	1200	2560	5														
72	144	288	848	2080	7														
64	128	240	720	1600	8														
43	96	200	488	1008	10														
109	176	400	1248	2400	12														
109	176	400	1248	2400	15														
123	240	480	1600	2880	20	2													
							123	240			480	1600	2880	25					
							123	240			480	1600	2880	32					
							104	224			416	1440	2880	40					
							64	128			240	720	1600	64					
							43	96			200	488	1008	100					

⁽¹⁾ 传动比 (i=n₁/n₂)

⁽²⁾ 减速机级数

⁽³⁾ 利用 NCP 针对应用进行专门设计 - www.neugart.com

⁽⁴⁾ 平键 (代码 "A")时的数值: 针对交变载荷

⁽⁵⁾ 允许输出轴转动30.000转; 参见第 166 页

⁽¹⁾ Ratios (i=n₁/n₂)

⁽²⁾ Number of stages

⁽³⁾ Application specific configuration with NCP - www.neugart.com

⁽⁴⁾ Values for feather key (code "A"): for repeated load

⁽⁵⁾ 30,000 rotations of the output shaft permitted; see page 167

输出扭矩	Output torques			PLN070	PLN090	PLN115	PLN142	PLN190	i ⁽¹⁾	p ⁽²⁾
急停扭矩 ⁽³⁾	Emergency stop torque ⁽³⁾	T _{2Stop}	Nm	90	210	490	975	2000	3	1
				120	280	650	1300	2700	4	
				130	280	650	1500	3200	5	
				80	175	340	1300	2600	7	
				90	200	380	1000	2600	8	
				90	200	480	750	1350	10	
				135	220	500	1500	3000	12	2
				135	220	500	1500	3000	15	
				150	300	650	2000	3600	16	
				150	300	650	2000	3600	20	
				150	300	650	1800	3600	25	
				150	300	650	2000	3600	32	
				150	300	650	1800	3600	40	
				80	200	380	1000	2600	64	
				80	200	480	750	1350	100	

输入转速	Input speeds			PLN070	PLN090	PLN115	PLN142	PLN190	i ⁽¹⁾	p ⁽²⁾
T _{2N} 和 S1 时的平均热输入转速 ⁽⁴⁾⁽⁵⁾	Average thermal input speed at T _{2N} and S1 ⁽⁴⁾⁽⁵⁾	n _{1N}	min ⁻¹	2050 ⁽⁶⁾	1950 ⁽⁶⁾	1500 ⁽⁶⁾	850 ⁽⁶⁾	700 ⁽⁶⁾	3	1
				2300 ⁽⁶⁾	2100 ⁽⁶⁾	1600 ⁽⁶⁾	950 ⁽⁶⁾	750 ⁽⁶⁾	4	
				2650 ⁽⁶⁾	2500 ⁽⁶⁾	2000 ⁽⁶⁾	1050 ⁽⁶⁾	850 ⁽⁶⁾	5	
				3450 ⁽⁶⁾	3550 ⁽⁶⁾	2800 ⁽⁶⁾	1550 ⁽⁶⁾	1200 ⁽⁶⁾	7	
				3800 ⁽⁶⁾	3950 ⁽⁶⁾	3200 ⁽⁶⁾	1800 ⁽⁶⁾	1450 ⁽⁶⁾	8	
				4400 ⁽⁶⁾	4000	3500 ⁽⁶⁾	2250 ⁽⁶⁾	1900 ⁽⁶⁾	10	
				3550 ⁽⁶⁾	3400 ⁽⁶⁾	2450 ⁽⁶⁾	1300 ⁽⁶⁾	1000 ⁽⁶⁾	12	2
				4000 ⁽⁶⁾	4000 ⁽⁶⁾	3000 ⁽⁶⁾	1600 ⁽⁶⁾	1250 ⁽⁶⁾	15	
				3800 ⁽⁶⁾	3550 ⁽⁶⁾	2550 ⁽⁶⁾	1350 ⁽⁶⁾	1050 ⁽⁶⁾	16	
				4300 ⁽⁶⁾	4000 ⁽⁶⁾	3050 ⁽⁶⁾	1600 ⁽⁶⁾	1300 ⁽⁶⁾	20	
				4500 ⁽⁶⁾	4000 ⁽⁶⁾	3400 ⁽⁶⁾	1850 ⁽⁶⁾	1400 ⁽⁶⁾	25	
				4500	4000	3500 ⁽⁶⁾	2300 ⁽⁶⁾	1900 ⁽⁶⁾	32	
				4500	4000	3500	2550 ⁽⁶⁾	2100 ⁽⁶⁾	40	
				4500	4000	3500	3000 ⁽⁶⁾	2500 ⁽⁶⁾	64	
				4500	4000	3500	3000	2500	100	

最高机械输入转速 ⁽⁴⁾	Max. mechanical input speed ⁽⁴⁾	n _{1Limit}	min ⁻¹	14000	10000	8500	6500	6000		
-------------------------	--	---------------------	-------------------	-------	-------	------	------	------	--	--

(1) 传动比 (i=n₁/n₂)
 (2) 减速机级数
 (3) 允许 1000 次
 (4) 利用 NCP 针对应用设计转速 – www.neugart.com
 (5) 定义请参见第 166 页
 (6) 在 50% T_{2N} 输出和 S1 模式下的平均热输入转速

(1) Ratios (i=n₁/n₂)
 (2) Number of stages
 (3) Permitted 1000 times
 (4) Application-specific speed configurations with NCP – www.neugart.com
 (5) See page 167 for the definition
 (6) Average thermal input speed at 50% T_{2N} and S1

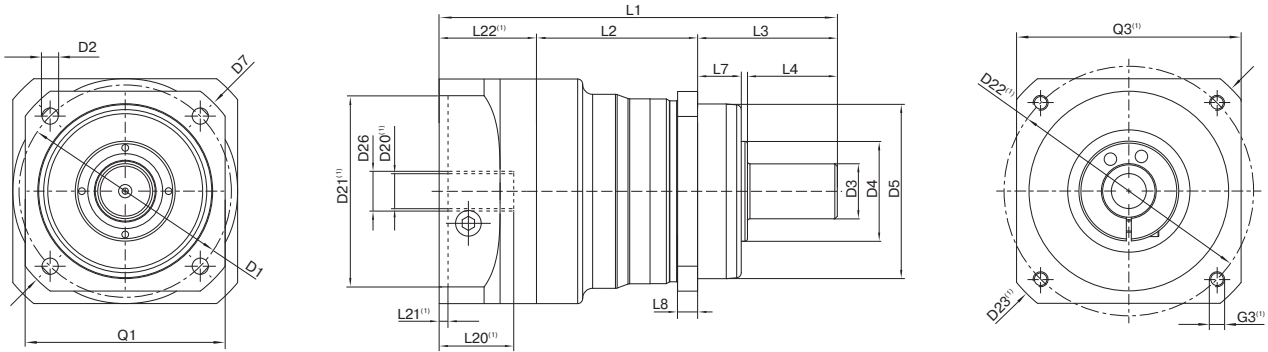

图示为带平键的 PLN090 / 1 级 / 光滑输出轴 / 19 mm 锁紧系统 / 适配电机法兰 - 2 件式 - 圆形通用法兰 / B5 电机法兰类型
 Drawing corresponds to a PLN090 / 1-stage / smooth output shaft / 19 mm clamping system / motor adaptation - 2-part - round universal flange / B5 flange type motor

⁽¹⁾ 具体尺寸视电机/减速机法兰而定。可以在 www.neugart.com 下 Tec Data Finder 中针对每个电机适配电机特有的输入法兰几何尺寸。
⁽¹⁾ The dimensions vary with the motor/gearbox flange. The input flange dimensions can be retrieved for each specific motor in Tec Data Finder at www.neugart.com

几何尺寸 ⁽²⁾	Geometry ⁽²⁾			PLN070	PLN090	PLN115	PLN142	PLN190	p ⁽³⁾	Code
输出端安装孔节圆直径	Pitch circle diameter output	D1		68 - 75	85	120	165	215		
输出端安装孔直径	Mounting bore output	D2	4x	5,5	6,5	9,0	11,0	13,5		
输出轴直径	Shaft diameter output	D3	k6	16	22	32	40	55		
输出轴轴肩直径	Shaft collar output	D4		35	40	45	70	80		
输出端定位凸台直径	Centering diameter output	D5	g7	60	70	90	130	160		
输出法兰对角线尺寸	Diagonal dimension output	D7		92	100	140	185	240		
输出端法兰外方	Flange cross section output	Q1	■	70	80	110	142	190		
最小总长	Min. total length	L1		137,5	159,5	201	276	310,5	1	
				166,5	191,5	241	335	382,5	2	
箱体长度	Housing length	L2		58,5	64,5	61	91,5	116	1	
				88	96,5	101,5	150,5	188	2	
输出端定位凸台深度	Centering depth output	L7		19	17,5	28	28	28		
输出端法兰厚度	Flange thickness output	L8		7	8	10	12	15		
电机轴直径 j6/k6	Motor shaft diameter j6/k6	D20		更多信息见第 163/164 页						
输入端锁紧系统直径	Clamping system diameter input	D26		More information on page 163/164						
带平键的输出轴 (DIN 6885-1)	Output shaft with feather key (DIN 6885-1)			A 5x5x25	A 6x6x28	A 10x8x50	A 12x8x65	A 16x10x70		A
平键宽度 (DIN 6885-1)	Feather key width (DIN 6885-1)	B1		5	6	10	12	16		
含平键在内的轴高 (DIN 6885-1)	Shaft height including feather key (DIN 6885-1)	H1		18	24,5	35	43	59		
输出轴轴长	Shaft length output	L3		48	56	88	110	112		
到轴肩的距离	Shaft length from shoulder	L4		28	36	58	80	82		
平键长度	Feather key length	L5		25	28	50	65	70		
到轴端的距离	Distance from shaft end	L6		2	4	4	8	6		
中心孔 (DIN 332, DR 形)	Center hole (DIN 332, type DR)	C		M5x12,5	M8x19	M12x28	M16x36	M20x42		
光滑输出轴	Smooth output shaft									B
输出轴轴长	Shaft length output	L3		48	56	88	110	112		
到轴肩的距离	Shaft length from shoulder	L4		28	36	58	80	82		
花键输出轴 (DIN 5480)	Splined output shaft (DIN 5480)			W16x0,8 x18x6m	W22x1,25 x16x6m	W32x1,25 x24x6m	W40x2,0 x18x6m	W55x2,0 x26x6m		C
花键或键槽的长度	Width of gearing	L _v		15	15	15	20	22		
输出轴轴长	Shaft length output	L3		46	46	56	70	71,5		
到轴肩的距离	Shaft length from shoulder	L4		26	26	26	40	41,5		
中心孔 (DIN 332, DR 形)	Center hole (DIN 332, type DR)	C		M5x12,5	M8x19	M12x28	M16x36	M20x42		

⁽²⁾ 所有的尺寸单位为mm
⁽³⁾ 减速机级数

⁽²⁾ Dimensions in mm
⁽³⁾ Number of stages



PSFN

负载量最高的精密型减速机 运行十分安静 采用法兰输出轴

我们的 **PSFN** 装有标准法兰接口以及笼状结构的行星齿轮架，因此抗扭刚度极高。专门研发的斜齿把振动降至最低程度。这种高精度行星减速机凭借它的高倾斜力矩，可以满足您的众多要求。

The precision planetary gearbox for maximum loads with particularly quiet drive and flange output shaft

Thanks to its standardized flange interface and a planet carrier in a cage design, our **PSFN** is extremely torsionally rigid. The specially developed helical gearing reduces vibrations to a minimum. With its high tilting moment, you can demand a lot from this precision planetary gearbox.

额定扭矩
Nominal output torque **14 - 950 Nm**

径向力
Radial force **1600 - 23000 N**

轴向力
Axial force **3550 - 16000 N**

回程间隙
Torsional backlash **1 - 8 arcmin**

防护等级
Protection class **IP65**

结构尺寸
Frame sizes

- 55
- 64
- 90
- 110
- 140
- 200

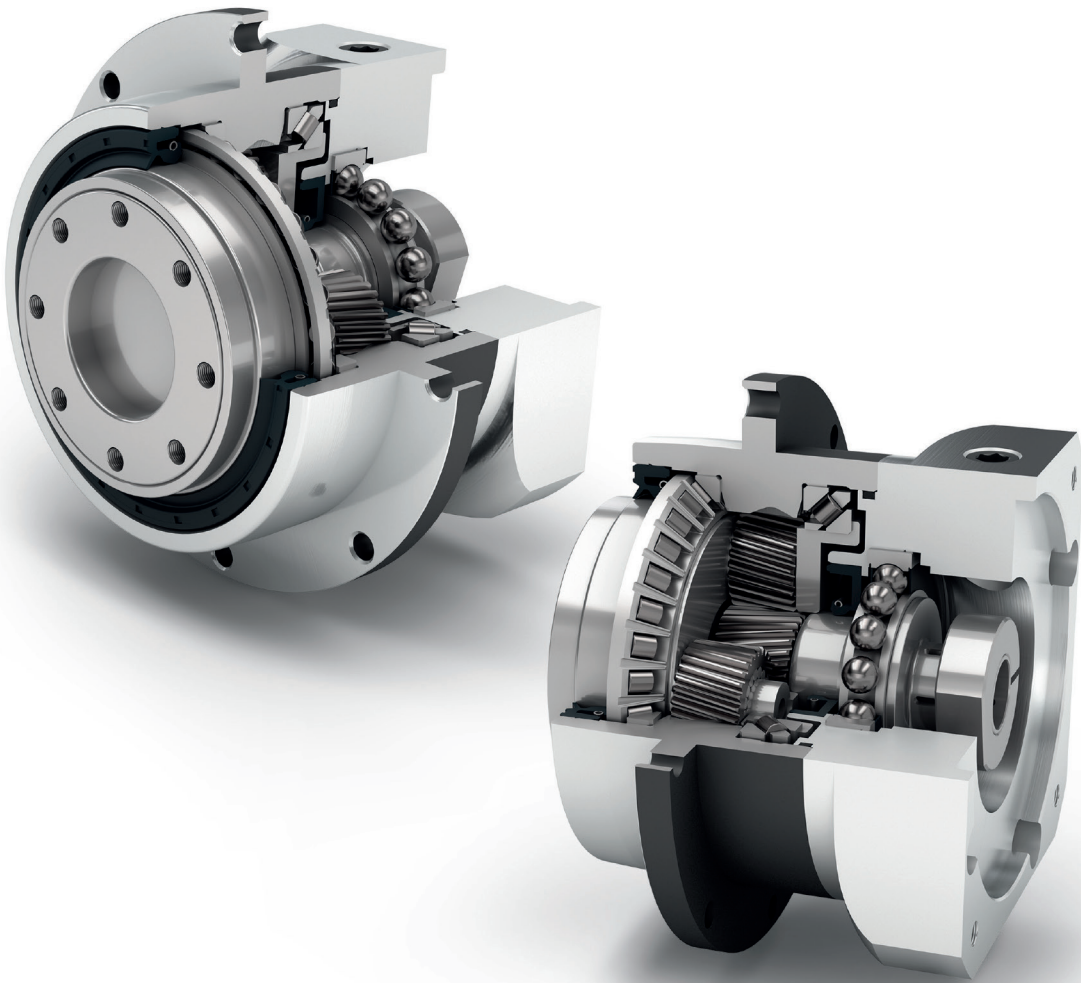

精密型
Precision Line



旋转方向 同方向
Equidirectional rotation

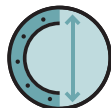

圆形特大号输出法兰
Extra large round type output flange



径向轴密封
Rotary shaft seal



行星齿轮架 (笼状结构)
Planet carrier in cage design



可选: 装有小齿轮的高精度减速机
132页
Option: Planetary gearbox with
mounted pinion on page 132

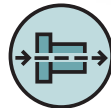

同轴减速机
Coaxial gearbox



斜齿
Helical gear



配有预紧的角接触滚子轴承
Preloaded angular contact roller bearings



法兰输出轴 (按 ISO 9409-1 标准)
Flange output shaft (ISO 9409-1)



可选: 降低回程间隙
Option: Reduced backlash



可选: 喷漆表面
——RAL 9005 黑色
Option: Painted surface
– RAL 9005 Jet black

技术特点的详细解释, 请从第173页读起。
Detailed explanations of the technical features starting on page 173.

Code	减速机参数	Gearbox characteristics			PSFN055	PSFN064	PSFN090	PSFN110	PSFN140	PSFN200	p ⁽¹⁾
	使用寿命 (L _{10h})	Service life (L _{10h})	t _L	h	20.000						
	T _{2N} × 0,88 时的使用寿命	Service life at T _{2N} × 0,88			30.000						
	满载时效率 ⁽²⁾	Efficiency at full load ⁽²⁾	η	%	97						1
					96						2
	最低工作温度	Min. operating temperature	T _{min}	°C	-25						
	最高工作温度	Max. operating temperature	T _{max}		90						
	防护等级	Protection class	IP65								
S	标准润滑	Standard lubrication	润滑油(终生润滑) / Oil (lifetime lubrication)								
F	食品级润滑	Food grade lubrication	润滑油(终生润滑) / Oil (lifetime lubrication)								
L	低温润滑 ⁽³⁾	Low temperature lubrication ⁽³⁾	润滑油(终生润滑) / Oil (lifetime lubrication)								
	安装位置	Installation position	任意 / Any								
S	标准回程间隙	Standard backlash	j _k	arcmin	< 6	< 3	< 3	< 3	< 3	< 3	1
					< 8	< 5	< 5	< 5	< 5	< 5	2
					< 4	< 2	< 1	< 1	< 1	< 1	1
					< 6	< 2	< 1	< 1	< 1	< 1	2
R	降低回程间隙	Reduced backlash									
	抗扭刚度 ⁽²⁾	Torsional stiffness ⁽²⁾	c _g	Nm / arcmin	2,8 - 6,2	8,2	21,0	55,0	129,0	374,0	1
					2,8 - 6,5	8,2	21,0	64,0	127,0	365,0	2
	减速机重量 ⁽²⁾	Gearbox weight ⁽²⁾	m _G	kg	0,7	1,3	2,9	4,9	11,5	28,1	1
					1,1	1,4	3,0	5,1	11,7	29,1	2
S	标准的箱体表面	Standard surface	箱体: 钢 - 热处理后氧化 (黑色) Housing: Steel - heat-treated and post-oxidized (black)								
B	喷漆表面	Painted surface	RAL 9005 黑色 RAL 9005 Jet black								
	运行噪音 ⁽⁴⁾	Running noise ⁽⁴⁾	Q _g	dB(A)	56	57	58	63	66	68	
	基于减速机输入法兰的最大弯矩 ⁽⁵⁾	Max. bending moment based on the gearbox input flange ⁽⁵⁾	M _b	Nm	10	18	38	80	180	300	1
					10	18	18	38	80	180	2

输出轴载荷	Output shaft loads			PSFN055	PSFN064	PSFN090	PSFN110	PSFN140	PSFN200	p ⁽¹⁾
20,000 h 径向力 ⁽⁶⁾⁽⁷⁾	Radial force for 20,000 h ⁽⁶⁾⁽⁷⁾	F _{r20.000h}	N	1450	2150	3950	4900	12000	23000	
20,000 h 轴向力 ⁽⁶⁾⁽⁷⁾	Axial force for 20,000 h ⁽⁶⁾⁽⁷⁾	F _{a20.000h}		2350	4300	8200	9500	8500	16000	
30,000 h 径向力 ⁽⁶⁾⁽⁷⁾	Radial force for 30,000 h ⁽⁶⁾⁽⁷⁾	F _{r30.000h}		1400	1900	3500	4350	11000	21000	
30,000 h 轴向力 ⁽⁶⁾⁽⁷⁾	Axial force for 30,000 h ⁽⁶⁾⁽⁷⁾	F _{a30.000h}		2350	3800	7200	8400	7500	14000	
最大径向力 ⁽⁷⁾⁽⁸⁾	Maximum radial force ⁽⁷⁾⁽⁸⁾	F _{r Stat}		1450	2150	3950	4900	12000	23000	
最大轴向力 ⁽⁷⁾⁽⁸⁾	Maximum axial force ⁽⁷⁾⁽⁸⁾	F _{a Stat}		2350	4300	8200	9500	8500	16000	
20,000 h 倾斜力矩 ⁽⁶⁾⁽⁸⁾	Tilting moment for 20,000 h ⁽⁶⁾⁽⁸⁾	M _{K20.000h}	Nm	75	132	326	475	1030	2445	
30,000 h 倾斜力矩 ⁽⁶⁾⁽⁸⁾	Tilting moment for 30,000 h ⁽⁶⁾⁽⁸⁾	M _{K30.000h}		73	117	289	422	944	2232	

转动惯量	Moment of inertia			PSFN055	PSFN064	PSFN090	PSFN110	PSFN140	PSFN200	p ⁽¹⁾
转动惯量 ⁽²⁾	Mass moment of inertia ⁽²⁾	J	kgcm ²	0,097	0,128	0,342	0,892	6,526	22,520	1
				0,117	0,188	0,611	1,741	9,670	40,642	
				0,095	0,124	0,125	0,325	0,853	6,434	2
				0,109	0,180	0,197	0,587	1,836	10,410	

(1) 减速机级数 (2) Number of stages
 (2) 传动比相关的数值可在 Tec Data Finder 中检索 - www.neugart.com (2) The ratio-dependent values can be retrieved in Tec Data Finder - www.neugart.com
 (3) T_{min} = -40°C. 理想运行温度最高为 50°C (3) T_{min} = -40°C. Optimal operating temperature max. 50°C
 (4) 距离减速机 1 m 时; 在输入转速为 n₁=3000 min⁻¹ 且无负荷时测得; i=5 (4) Sound pressure level from 1 m, measured on input running at n₁=3000 rpm no load; i=5
 (5) 最大电机重量* (单位: kg) = 0.2 × M_b / 电机长度 (单位: m) (5) Max. motor weight* in kg = 0.2 × M_b / motor length in m
 * 电机重量对称分布 * with symmetrically distributed motor weight
 * 水平和固定的安装位置 * with horizontal and stationary mounting
 (6) 数据以 n₂=100 min⁻¹ 的输出轴转速为准 (6) These values are based on an output shaft speed of n₂=100 rpm
 (7) 以输出轴中心为准 (7) Based on the end of the output shaft
 (8) 更改 T_{2N}, F_r, F_a 以及周期和轴承使用寿命时, 数值存在偏差(部分较高)。利用 NCP 针对应用进行专门设计 - www.neugart.com (8) Other (sometimes higher) values following changes to T_{2N}, F_r, F_a, cycle, and service life of bearing. Application specific configuration with NCP - www.neugart.com

输出扭矩	Output torques			PSFN055	PSFN064	PSFN090	PSFN110	PSFN140	PSFN200	i ⁽¹⁾	p ⁽²⁾
额定输出扭矩 ⁽³⁾	Nominal output torque ⁽³⁾	T _{2N}	Nm	18	39	80	180	470	950	4	1
				18	40	80	175	405	950	5	
				18	37	78	175	355	900	7	
				18	39	75	155	350	-	8	
				13,5	28	59	140	305	750	10	2
				18	39	80	180	450	950	16	
				18	39	80	180	450	950	20	
				18	40	80	175	405	950	25	
				18	40	80	175	405	950	35	
				18	39	80	180	470	950	40	
				18	40	80	175	405	950	50	
				18	37	78	175	355	900	70	
				13,5	28	59	140	305	750	100	
				最大输出扭矩 ⁽⁴⁾	Max. output torque ⁽⁴⁾	T _{2max}	Nm	29	62	128	
29	64	128	280					648	1520	5	
29	59	125	280					568	1440	7	
29	62	120	248					560	-	8	
22	45	94	224					488	1200	10	2
29	62	128	288					720	1520	16	
29	62	128	288					720	1520	20	
29	64	128	280					648	1520	25	
29	64	128	280					648	1520	35	
29	62	128	288					752	1520	40	
29	64	128	280					648	1520	50	
29	59	125	280					568	1440	70	
22	45	94	224					488	1200	100	

⁽¹⁾ 传动比 (i=n₁/n₂)

⁽²⁾ 减速机级数

⁽³⁾ 利用 NCP 针对应用进行专门设计 – www.neugart.com

⁽⁴⁾ 允许输出轴转动30.000转；参见第 166 页

⁽¹⁾ Ratios (i=n₁/n₂)

⁽²⁾ Number of stages

⁽³⁾ Application specific configuration with NCP – www.neugart.com

⁽⁴⁾ 30,000 rotations of the output shaft permitted; see page 167

输出扭矩	Output torques			PSFN055	PSFN064	PSFN090	PSFN 110	PSFN 140	PSFN200	i ⁽¹⁾	p ⁽²⁾
急停扭矩 ⁽³⁾	Emergency stop torque ⁽³⁾	T _{2Stop}	Nm	90	120	280	650	1650	3200	4	1
				90	130	280	650	1650	3200	5	
				70	80	175	340	1300	3200	7	
				50	90	200	380	1100	-	8	
				24	90	200	480	600	1700	10	
				90	150	300	650	1650	3200	16	2
				90	150	300	650	1650	3200	20	
				90	150	300	650	1650	3200	25	
				90	150	300	650	1650	3200	35	
				90	150	300	650	1650	3200	40	
				90	150	300	650	1650	3200	50	
				70	80	175	340	1300	3200	70	
				24	90	200	480	600	1700	100	

输入转速	Input speeds			PSFN055	PSFN064	PSFN090	PSFN 110	PSFN 140	PSFN200	i ⁽¹⁾	p ⁽²⁾
T _{2N} 和 S1 时的平均热输入转速 ⁽⁴⁾⁽⁵⁾	Average thermal input speed at T _{2N} and S1 ⁽⁴⁾⁽⁵⁾	n _{1N}	min ⁻¹	4800 ⁽⁶⁾	3200 ⁽⁶⁾	2400 ⁽⁶⁾	1800 ⁽⁶⁾	1100 ⁽⁶⁾	750 ⁽⁶⁾	4	1
				5000 ⁽⁶⁾	3800 ⁽⁶⁾	2950 ⁽⁶⁾	2250 ⁽⁶⁾	1350 ⁽⁶⁾	950 ⁽⁶⁾	5	
				5000	4500	3800 ⁽⁶⁾	2950 ⁽⁶⁾	1800 ⁽⁶⁾	1250 ⁽⁶⁾	7	
				5000	4500	4000 ⁽⁶⁾	3300 ⁽⁶⁾	1950 ⁽⁶⁾	-	8	
				5000	4500	4000	3500	2300 ⁽⁶⁾	1700 ⁽⁶⁾	10	
				5000 ⁽⁶⁾	4500	4500	3800 ⁽⁶⁾	2450 ⁽⁶⁾	1550 ⁽⁶⁾	16	2
				5000	4500	4500	4000	3050 ⁽⁶⁾	1900 ⁽⁶⁾	20	
				5000	4500	4500	4000	3350 ⁽⁶⁾	2050 ⁽⁶⁾	25	
				5000	4500	4500	4000	3500	2650 ⁽⁶⁾	35	
				5000	4500	4500	4000	3500	3000 ⁽⁶⁾	40	
				5000	4500	4500	4000	3500	3000	50	
				5000	4500	4500	4000	3500	3000	70	
				5000	4500	4500	4000	3500	3000	100	
				最高机械输入转速 ⁽⁴⁾	Max. mechanical input speed ⁽⁴⁾	n _{1Limit}	min ⁻¹	10000	14000	10000	
10000	14000	14000	10000					8500	6500		2

⁽¹⁾ 传动比 (i=n₁/n₂)

⁽²⁾ 减速级数

⁽³⁾ 允许 1000 次

⁽⁴⁾ 利用 NCP 针对应用设计转速 – www.neugart.com

⁽⁵⁾ 定义请参见第 166 页

⁽⁶⁾ 在 50% T_{2N} 输出和 S1 模式下的平均热输入转速

⁽¹⁾ Ratios (i=n₁/n₂)

⁽²⁾ Number of stages

⁽³⁾ Permitted 1000 times

⁽⁴⁾ Application-specific speed configurations with NCP – www.neugart.com

⁽⁵⁾ See page 167 for the definition

⁽⁶⁾ Average thermal input speed at 50% T_{2N} and S1

PSFN055
PSFN064
PSFN090

PSFN110

PSFN140
PSFN200

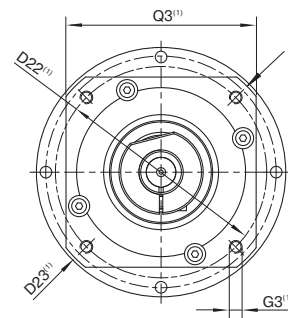
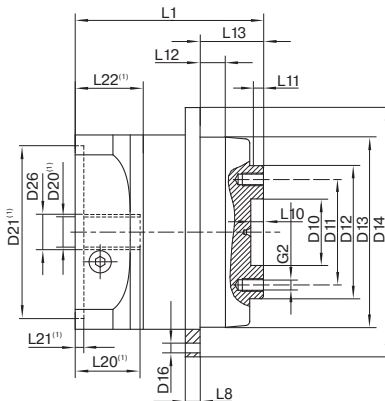
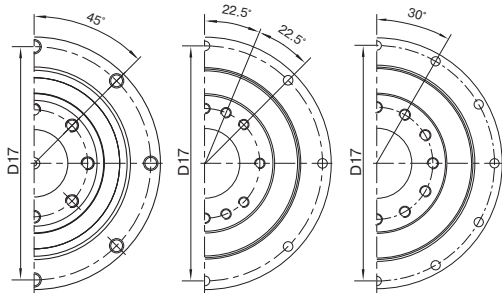

图示为带平键的 PSFN090 / 1 级 / 法兰输出轴 / 14 mm 锁紧系统 / 适配电机法兰 - 2 件式 - 圆形通用法兰 / B5 电机法兰类型

Drawing corresponds to a PSFN090 / 1-stage / flange output shaft / 14 mm clamping system / motor adaptation - 2-part - round universal flange / B5 flange type motor

(1) 具体尺寸视电机/减速机法兰而定。可以在 www.neugart.com 下 Tec Data Finder。中针对每个电机适配电机特有的输入法兰几何尺寸。

(1) The dimensions vary with the motor/gearbox flange. The input flange dimensions can be retrieved for each specific motor in Tec Data Finder at www.neugart.com

几何尺寸 ⁽¹⁾	Geometry ⁽¹⁾			PSFN055	PSFN064	PSFN090	PSFN110	PSFN140	PSFN200	p ⁽²⁾	Code
输出端定位凹槽直径	Centering Ø output shaft	D10	H7	16	20	31,5	40	50	80		
输出端安装孔节圆直径	Pitch circle Ø output shaft	D11		25	31,5	50	63	80	125		
输出轴定位凸台直径	Centering Ø output shaft	D12	h7	34	40	63	80	100	160		
输出法兰定位凸台直径	Centering Ø output flange	D13		55	64	90	110	140	200		
输出法兰直径	Flange diameter output	D14		72	86	118	145	179	247		
输出端安装孔直径	Mounting bore output	D16		3,4 8x45°	4,5 8x45°	5,5 8x45°	5,5 8x45°	6,6 12x30°	9 12x30°		
输出法兰安装孔节圆直径	Pitch circle Ø output flange	D17		67	79	109	135	168	233		
最小总长	Min. total length	L1		66	71	89,5	108	142	172	1	
				89,5	99,5	111,5	130	173	217	2	
输出端法兰厚度	Flange thickness output	L8		4	4	7	8	10	12		
输出轴定位凸台深度	Centering depth output shaft	L10		4,1	4,5	6,5	6,5	6,5	10		
		L11		3	3	6	6	6	7		
输出法兰定位凸台深度	Centering depth output flange	L12		8	10	12	12	14	17,5		
输出法兰长度	Output flange length	L13		19,0	19,5	30,0	29,0	38,0	50,0		
电机轴直径j6/k6	Motor shaft diameter j6/k6	D20		更多信息见第 163/164 页							
输入端锁紧系统直径	Clamping system Ø input	D26		More information on page 163/164							
法兰输出轴 (相似的 ISO 9409-1)	Flange output shaft (similar ISO 9409-1)										
数量 x 螺纹 x 深度	Number x thread x depth	G2		8 x M4x6	8 x M5x7	8 x M6x10	12 x M6x12	12 x M8x15	12 x M10x20		D
带有配合销孔的法兰输出轴 (ISO 9409-1)	Flange output shaft with dowel hole (ISO 9409-1)										
配合销孔 x 深度	Dowel hole x depth	D15	H7	4x5	5x5	6x6	6x6	8x8	10x10		E
数量 x 螺纹 x 深度	Number x thread x depth	G2		7 x M4x6	7 x M5x7	7 x M6x10	11 x M6x12	11 x M8x15	11 x M10x20		

(1) 所有的尺寸单位为mm

(2) 减速机级数

(1) Dimensions in mm

(2) Number of stages



PLFN

负载极大的精密减速机
且性能极高
安装便捷

我们的 **PLFN** 具有标准的法兰接口，因此可以实现简便的安装。直齿高精度行星减速机是针对最高的性能和扭矩设计的。它具有较高的倾斜力矩，即使在承受极高的径向力和轴向力时仍然保持最佳性能。

The precision planetary gearbox for maximum loads and the highest performance – fast and easy to install

Our **PLFN** has a standardized flange interface, which allows easy mounting. The straight-toothed precision planetary gearbox is designed for high performance and torque. Its high tilting moment allows the best performance even with the highest radial and axial forces.

额定扭矩 Nominal output torque	27 - 1800 Nm
径向力 Radial force	2150 - 33000 N
轴向力 Axial force	4300 - 15000 N
回程间隙 Torsional backlash	1 - 5 arcmin
防护等级 Protection class	IP65

结构尺寸
Frame sizes

- 64
- 90
- 110
- 140
- 200

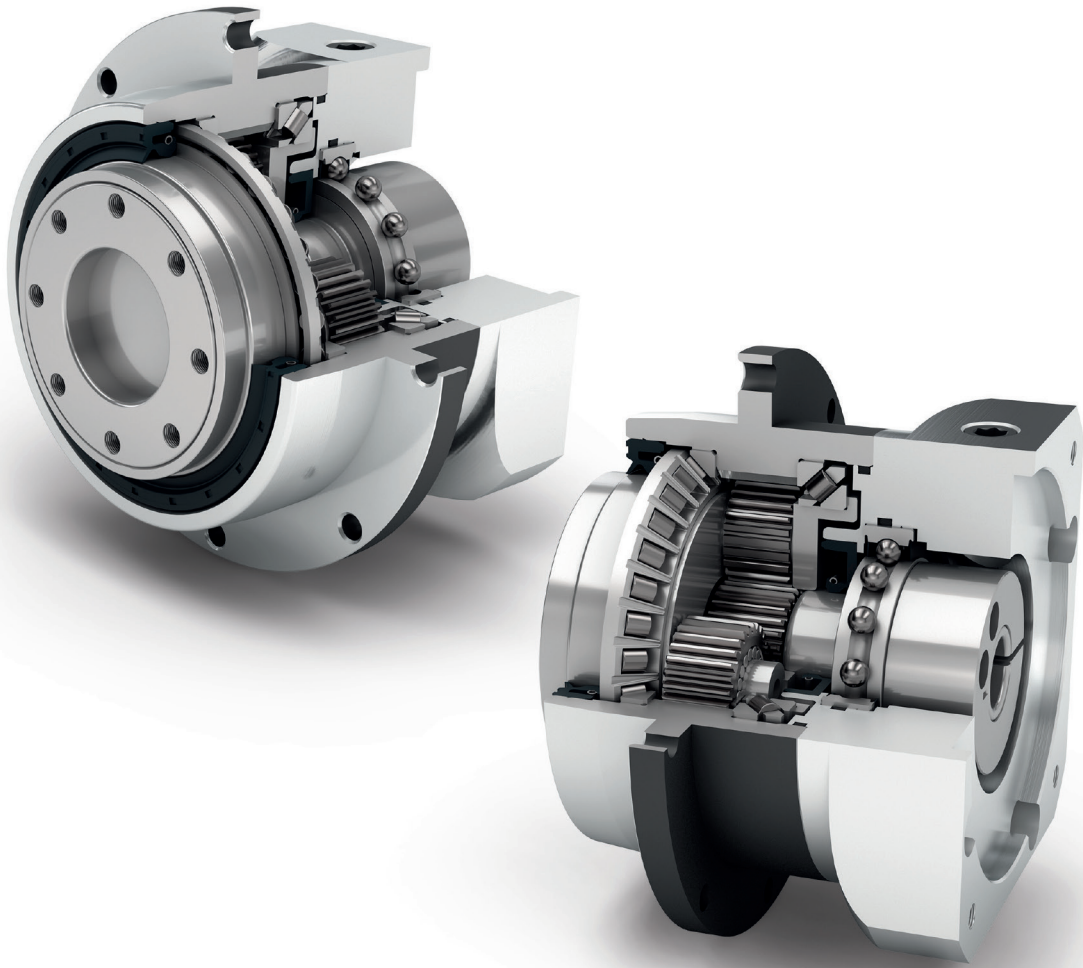

精密型
Precision Line



旋转方向 同方向
Equidirectional rotation



圆形特大号输出法兰
Extra large round type output flange



径向轴密封
Rotary shaft seal



行星齿轮架 (笼状结构)
Planet carrier in cage design



可选: 装有小齿轮的高精度减速机
132页
Option: Planetary gearbox with
mounted pinion on page 132

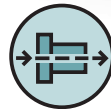

同轴减速机
Coaxial gearbox



直齿
Spur gear



配有预紧的角接触滚子轴承
Preloaded angular contact roller bearings



法兰输出轴 (按 ISO 9409-1 标准)
Flange output shaft (ISO 9409-1)



可选: 降低回程间隙
Option: Reduced backlash



可选: 喷漆表面
——RAL 9005 黑色
Option: Painted surface
– RAL 9005 Jet black

技术特点的详细解释, 请从第173页读起。
Detailed explanations of the technical features starting on page 173.

Code	减速机参数	Gearbox characteristics			PLFN064	PLFN090	PLFN110	PLFN140	PLFN200	p ⁽¹⁾	
	使用寿命 (L _{10h})	Service life (L _{10h})	t _L	h	20.000						
	T _{2N} × 0,88 时的使用寿命	Service life at T _{2N} × 0,88			30.000						
	满载时效率 ⁽²⁾	Efficiency at full load ⁽²⁾	η	%	97					1	
	最低工作温度	Min. operating temperature	T _{min}	°C	-25						
	最高工作温度	Max. operating temperature	T _{max}		90						
	防护等级	Protection class	IP65								
S	标准润滑	Standard lubrication	润滑油(终生润滑) / Oil (lifetime lubrication)								
F	食品级润滑	Food grade lubrication	润滑油(终生润滑) / Oil (lifetime lubrication)								
L	低温润滑 ⁽³⁾	Low temperature lubrication ⁽³⁾	润滑油(终生润滑) / Oil (lifetime lubrication)								
	安装位置	Installation position	任意 / Any								
S	标准回程间隙	Standard backlash	j _t	arcmin	< 3					1	
R	降低回程间隙	Reduced backlash			< 5					2	
	抗扭刚度 ⁽²⁾	Torsional stiffness ⁽²⁾	C _G	Nm / arcmin	7,7 - 14,8	22,0 - 40,5	59,0 - 92,0	156,0 - 255,0	330,0 - 636,0	1	
					7,6 - 14,7	18,5 - 38,0	58,0 - 91,0	177,0 - 264,0	391,0 - 656,0	2	
	减速机重量 ⁽²⁾	Gearbox weight ⁽²⁾	m _G	kg	1,3	2,9	4,9 - 5,2	12,6 - 13,2	36,6 - 38,8	1	
					1,8 - 1,9	3,3 - 3,4	5,8 - 6,1	14,4 - 15,0	42,3 - 44,7	2	
S	标准的箱体表面	Standard surface	箱体: 钢 - 热处理后氧化 (黑色)								
B	喷漆表面	Painted surface	RAL 9005 黑色								
			RAL 9005 Jet black								
	运行噪音 ⁽⁴⁾	Running noise ⁽⁴⁾	Q _G	dB(A)	60	62	65	70	74		
	基于减速机输入法兰的最大弯矩 ⁽⁵⁾	Max. bending moment based on the gearbox input flange ⁽⁵⁾	M _b	Nm	18	38	80	180	300	1	
					18	18	38	80	180	2	

输出轴载荷	Output shaft loads			PLFN064	PLFN090	PLFN110	PLFN140	PLFN200	p ⁽¹⁾
20,000 h 径向力 ⁽⁶⁾⁽⁷⁾	Radial force for 20,000 h ⁽⁶⁾⁽⁷⁾	F _{r20.000h}	N	2150	3950	4900	12000	33000	
20,000 h 轴向力 ⁽⁶⁾⁽⁷⁾	Axial force for 20,000 h ⁽⁶⁾⁽⁷⁾	F _{a20.000h}		4300	8200	9500	8500	15000	
30,000 h 径向力 ⁽⁶⁾⁽⁷⁾	Radial force for 30,000 h ⁽⁶⁾⁽⁷⁾	F _{r30.000h}		1900	3500	4350	11000	29500	
30,000 h 轴向力 ⁽⁶⁾⁽⁷⁾	Axial force for 30,000 h ⁽⁶⁾⁽⁷⁾	F _{a30.000h}		3800	7200	8400	7500	13500	
最大径向力 ⁽⁷⁾⁽⁸⁾	Maximum radial force ⁽⁷⁾⁽⁸⁾	F _{r Stat}		2150	3950	4900	12000	33000	
最大轴向力 ⁽⁷⁾⁽⁸⁾	Maximum axial force ⁽⁷⁾⁽⁸⁾	F _{a Stat}		4300	8200	9500	8500	15000	
20,000 h 倾斜力矩 ⁽⁶⁾⁽⁸⁾	Tilting moment for 20,000 h ⁽⁶⁾⁽⁸⁾	M _{K20.000h}	Nm	132	326	475	1219	4957	
30,000 h 倾斜力矩 ⁽⁶⁾⁽⁸⁾	Tilting moment for 30,000 h ⁽⁶⁾⁽⁸⁾	M _{K30.000h}		117	289	422	1117	4431	

转动惯量	Moment of inertia			PLFN064	PLFN090	PLFN110	PLFN140	PLFN200	p ⁽¹⁾
转动惯量 ⁽²⁾	Mass moment of inertia ⁽²⁾	J	kgcm ²	0,217	0,580	2,036	7,313	26,880	1
				0,288	0,920	2,942	12,365	61,170	
				0,209	0,211	0,546	1,951	6,911	2
				0,243	0,269	0,737	2,784	11,813	

(1) 减速机级数
 (2) 传动比相关的数值可在 Tec Data Finder 中检索 - www.neugart.com
 (3) T_{min} = -40°C. 理想运行温度最高为 50°C
 (4) 距离减速机 1 m 时; 在输入转速为 n₁=3000 min⁻¹ 且无负荷时测得; i=5
 (5) 最大电机重量* (单位: kg) = 0.2 × M_b / 电机长度 (单位: m)
 * 电机重量对称分布
 * 水平和固定的安装位置
 (6) 数据以 n₂=100 min⁻¹ 的输出轴转速为准。
 (7) 以输出轴中心为准
 (8) 更改 T_{2N}, F_r, F_a 以及周期和轴承使用寿命时, 数值存在偏差(部分较高)。利用 NCP 针对应用进行专门设计 - www.neugart.com

(1) Number of stages
 (2) The ratio-dependent values can be retrieved in Tec Data Finder - www.neugart.com
 (3) T_{min} = -40°C. Optimal operating temperature max. 50°C
 (4) Sound pressure level from 1 m, measured on input running at n₁=3000 rpm no load; i=5
 (5) Max. motor weight* in kg = 0.2 × M_b / motor length in m
 * with symmetrically distributed motor weight
 * with horizontal and stationary mounting
 (6) These values are based on an output shaft speed of n₂=100 rpm
 (7) Based on the end of the output shaft
 (8) Other (sometimes higher) values following changes to T_{2N}, F_r, F_a, cycle, and service life of bearing. Application specific configuration with NCP - www.neugart.com

输出扭矩	Output torques			PLFN064	PLFN090	PLFN110	PLFN140	PLFN200	i ⁽¹⁾	p ⁽²⁾
额定输出扭矩 ⁽³⁾	Nominal output torque ⁽³⁾	T _{2N}	Nm	60	140	300	600	1300	4	1
				65	140	260	750	1600	5	
				45	90	180	530	1300	7	
				40	80	150	450	1000	8	
				27	60	125	305	630	10	
				77	150	300	1000	1800	16	2
				77	150	300	1000	1800	20	
				65	140	260	900	1800	25	
				77	150	300	600	1800	32	
				65	140	260	750	1800	40	
				65	130	260	620	1525	50	
				40	80	150	450	1000	64	
				27	60	125	305	630	100	
				96	224	480	960	2080	4	
104	224	416	1200	2560	5					
72	144	288	848	2080	7					
64	128	240	720	1600	8					
43	96	200	488	1008	10					
最大输出扭矩 ⁽⁴⁾	Max. output torque ⁽⁴⁾	T _{2max}	Nm	123	240	480	1600	2880	16	2
				123	240	480	1600	2880	20	
				104	224	416	1440	2880	25	
				123	240	480	960	2880	32	
				104	224	416	1200	2880	40	
				104	208	416	992	2440	50	
				64	128	240	720	1600	64	
				43	96	200	488	1008	100	

⁽¹⁾ 传动比 (i=n₁/n₂)

⁽²⁾ 减速机级数

⁽³⁾ 利用 NCP 针对应用进行专门设计 – www.neugart.com

⁽⁴⁾ 允许输出轴转动30.000转; 参见第 166 页

⁽¹⁾ Ratios (i=n₁/n₂)

⁽²⁾ Number of stages

⁽³⁾ Application specific configuration with NCP – www.neugart.com

⁽⁴⁾ 30,000 rotations of the output shaft permitted; see page 167

输出扭矩	Output torques			PLFN064	PLFN090	PLFN110	PLFN140	PLFN200	i ⁽¹⁾	p ⁽²⁾
急停扭矩 ⁽³⁾	Emergency stop torque ⁽³⁾	T _{2Stop}	Nm	120	280	650	1300	2700	4	1
				130	280	650	1500	3200	5	
				90	175	340	1300	2600	7	
				90	200	380	1000	2600	8	
				90	200	480	750	1350	10	
				150	300	650	2000	3600	16	2
				150	300	650	2000	3600	20	
				150	300	650	1800	3600	25	
				150	300	650	1500	3600	32	
				150	300	650	1500	3600	40	
				150	300	650	1500	3600	50	
				80	200	380	1000	2600	64	
				80	200	480	750	1350	100	

输入转速	Input speeds			PLFN064	PLFN090	PLFN110	PLFN140	PLFN200	i ⁽¹⁾	p ⁽²⁾
T _{2N} 和 S1 时的平均热输入转速 ⁽⁴⁾⁽⁵⁾	Average thermal input speed at T _{2N} and S1 ⁽⁴⁾⁽⁵⁾	n _{1N}	min ⁻¹	2100 ⁽⁶⁾	1750 ⁽⁶⁾	1300 ⁽⁶⁾	850 ⁽⁶⁾	500 ⁽⁶⁾	4	1
				2450 ⁽⁶⁾	2100 ⁽⁶⁾	1650 ⁽⁶⁾	950 ⁽⁶⁾	600 ⁽⁶⁾	5	
				3200 ⁽⁶⁾	3000 ⁽⁶⁾	2350 ⁽⁶⁾	1400 ⁽⁶⁾	850 ⁽⁶⁾	7	
				3550 ⁽⁶⁾	3350 ⁽⁶⁾	2650 ⁽⁶⁾	1650 ⁽⁶⁾	1000 ⁽⁶⁾	8	
				4100 ⁽⁶⁾	4000 ⁽⁶⁾	3150 ⁽⁶⁾	2050 ⁽⁶⁾	1300 ⁽⁶⁾	10	
				3700 ⁽⁶⁾	3850 ⁽⁶⁾	3150 ⁽⁶⁾	1700 ⁽⁶⁾	1100 ⁽⁶⁾	16	2
				4200 ⁽⁶⁾	4450 ⁽⁶⁾	3750 ⁽⁶⁾	2100 ⁽⁶⁾	1350 ⁽⁶⁾	20	
				4500 ⁽⁶⁾	4500 ⁽⁶⁾	4000 ⁽⁶⁾	2500 ⁽⁶⁾	1550 ⁽⁶⁾	25	
				4500 ⁽⁶⁾	4500	4000	3500 ⁽⁶⁾	2000 ⁽⁶⁾	32	
				4500	4500	4000	3500 ⁽⁶⁾	2250 ⁽⁶⁾	40	
				4500	4500	4000	3500	2750 ⁽⁶⁾	50	
				4500	4500	4000	3500	3000 ⁽⁶⁾	64	
				4500	4500	4000	3500	3000	100	
				最高机械输入转速 ⁽⁴⁾	Max. mechanical input speed ⁽⁴⁾	n _{1Limit}	min ⁻¹	14000	10000	
14000	14000	10000	8500					6500		2

⁽¹⁾ 传动比 (i=n₁/n₂)

⁽²⁾ 减速机级数

⁽³⁾ 允许 1000 次

⁽⁴⁾ 利用 NCP 针对应用设计转速 – www.neugart.com

⁽⁵⁾ 定义请参见第 166 页

⁽⁶⁾ 在 50% T_{2N} 输出和 S1 模式下的平均热输入转速

⁽¹⁾ Ratios (i=n₁/n₂)

⁽²⁾ Number of stages

⁽³⁾ Permitted 1000 times

⁽⁴⁾ Application-specific speed configurations with NCP – www.neugart.com

⁽⁵⁾ See page 167 for the definition

⁽⁶⁾ Average thermal input speed at 50% T_{2N} and S1

PLFN064
PLFN090

PLFN110

PLFN140
PLFN200

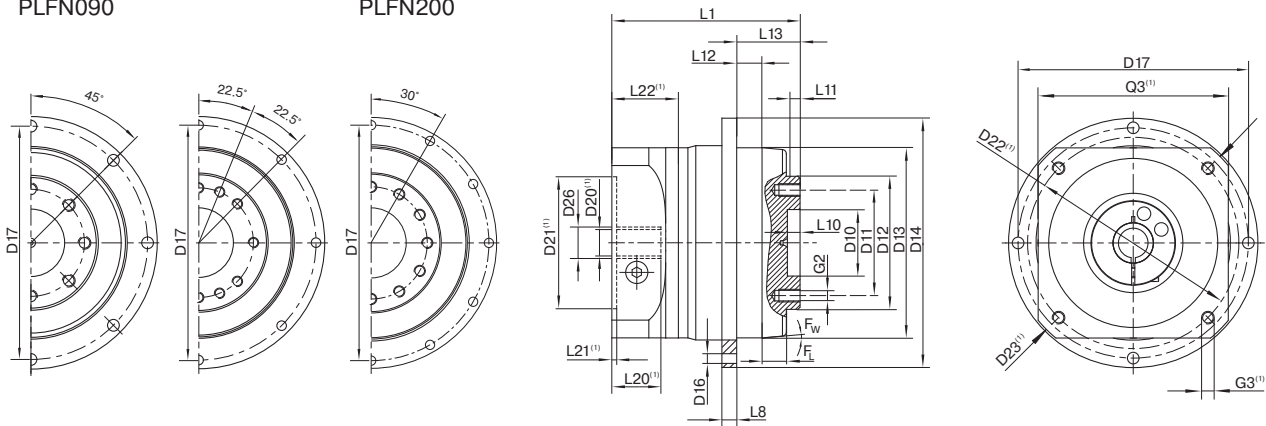

图示为带平键的 PLFN090 / 1 级 / 法兰输出轴 / 19 mm 锁紧系统 / 适配电机法兰 - 2 件式 - 圆形通用法兰 / B5 电机法兰类型
Drawing corresponds to a PLFN090 / 1-stage / flange output shaft / 19 mm clamping system / motor adaptation - 2-part - round universal flange / B5 flange type motor

(1) 具体尺寸视电机/减速机法兰而定。可以在 www.neugart.com 下 Tec Data Finder 中针对每个电机适配电机特有的输入法兰几何尺寸。
(1) The dimensions vary with the motor/gearbox flange. The input flange dimensions can be retrieved for each specific motor in Tec Data Finder at www.neugart.com

几何尺寸 ⁽²⁾	Geometry ⁽²⁾			PLFN064	PLFN090	PLFN110	PLFN140	PLFN200	p ⁽³⁾	Code
输出端定位凹槽直径	Centering diameter output shaft	D10	H7	20	31,5	40	50	80		
输出端安装孔节圆直径	Pitch circle diameter output shaft	D11		31,5	50	63	80	125		
法兰输出轴的直径	Flange output shaft diameter	D12	h7	40	63	80	100	160		
输出法兰定位凸台直径	Centering diameter output flange	D13		64	90	110	140	200		
输出法兰直径	Flange diameter output	D14		86	118	145	179	247		
输出端安装孔直径	Mounting bore output	D16		4,5 8x45°	5,5 8x45°	5,5 8x45°	6,6 12x30°	9 12x30°		
输出法兰安装孔节圆直径	Pitch circle diameter output flange	D17		79	109	135	168	233		
最小总长	Min. total length	L1		71	89	108	157	212,5	1	
				99,5	111	130	187,5	264	2	
输出端法兰厚度	Flange thickness output	L8		4	7	8	10	12		
输出轴定位凸台深度	Centering depth output shaft	L10		4,5	6,5	6,5	6,5	10		
		L11		3	6	6	6	8		
输出法兰定位凸台深度	Centering depth output flange	L12		10	12	12	14	17,5		
输出法兰长度	Output flange length	L13		19,5	30,0	29,0	38,0	50,0		
电机轴直径j6/k6	Motor shaft diameter j6/k6	D20		更多信息见第 163/164 页 More information on page 163/164						
输入端锁紧系统直径	Clamping system diameter input	D26								
法兰输出轴 (相似的 ISO 9409-1)	Flange output shaft (similar ISO 9409-1)									
数量 x 螺纹 x 深度	Number x thread x depth	G2		8 x M5x7	8 x M6x10	12 x M6x12	12 x M8x15	12 x M10x20		D
带有配合销孔的法兰输出轴 (ISO 9409-1)	Flange output shaft with dowel hole (ISO 9409-1)									
配合销孔 x 深度	Dowel hole x depth	D15	H7	5x5	6x6	6x6	8x8	10x10		E
数量 x 螺纹 x 深度	Number x thread x depth	G2		7 x M5x7	7 x M6x10	11 x M6x12	11 x M8x15	11 x M10x20		

(2) 所有的尺寸单位为mm
(3) 减速机级数

(2) Dimensions in mm
(3) Number of stages



WPLN

用途广泛、带有准双曲面齿轮的直角行星减速机，令驱动装置安静运行

我们的 **WPLN** 凭借其准双曲面齿轮达到最优同步。由于振动被降至最低程度，它可以均匀、精确且安静地运行。直角高精度减速机经过终身润滑，可以用多种方式安装。

The versatile right-angle gearbox with hypoid gearing for a quiet drive

Due to its hypoid gearing, our **WPLN** achieves optimal synchronization. Because vibrations are reduced to a minimum, it operates smoothly, precisely and quietly. The right-angle precision gearbox is lubricated for life and can be mounted in a variety of ways.

额定扭矩

Nominal output torque **22 - 800 Nm**

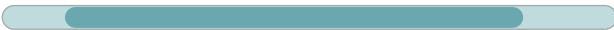

径向力

Radial force **3200 - 12500 N**



轴向力

Axial force **4300 - 15000 N**



回程间隙

Torsional backlash **3 - 5 arcmin**



防护等级

Protection class **IP65**



结构尺寸

Frame sizes

70

90

115

142

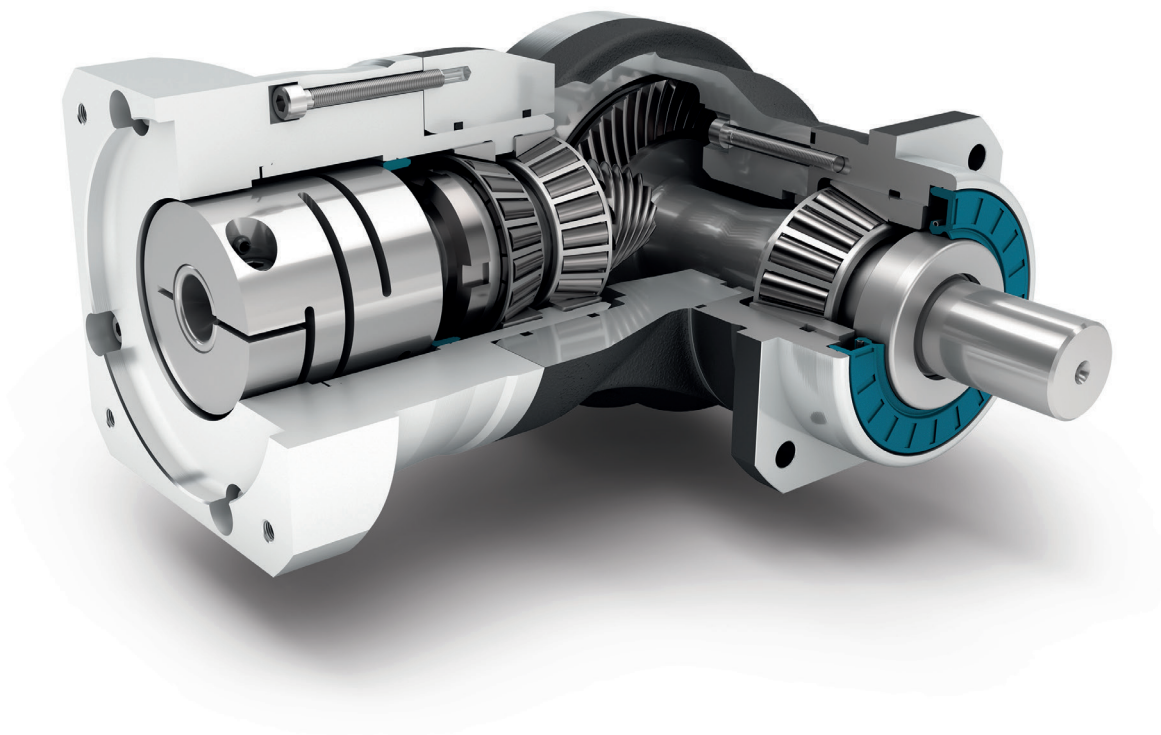

精密型
Precision Line



直角型减速机
Right angle gearbox



准双曲面齿轮 直角箱
Hypoid gear right angle stage



配有预紧的圆锥滚子轴承
Preloaded tapered roller bearings



输出端带有超长定心环
Extra long centering collar



0可选：装有小齿轮的高精度减速机
132页
Option: Planetary gearbox with
mounted pinion on page 132



旋转方向 反方向
Counterdirectional rotation



正方形输出法兰
Square type output flange



径向轴密封
Rotary shaft seal



可选：降低回程间隙 (2级)
Option: Reduced backlash (2-stage)



可选：喷漆表面
——RAL 9005 黑色
Option: Painted surface
- RAL 9005 Jet black

技术特点的详细解释，请从第173页读起。
Detailed explanations of the technical features starting on page 173.

Code	减速机参数	Gearbox characteristics			WPLN070	WPLN090	WPLN115	WPLN142	p ⁽¹⁾		
	使用寿命 (L _{10h})	Service life (L _{10h})	t _L	h	20.000						
	T _{2N} × 0,88 时的使用寿命	Service life at T _{2N} × 0,88			30.000						
	满载时效率 ⁽²⁾	Efficiency at full load ⁽²⁾	η	%	95				1		
	最低工作温度	Min. operating temperature	T _{min}	°C	-25						
	最高工作温度	Max. operating temperature	T _{max}		90						
	防护等级	Protection class					IP65				
S	标准润滑	Standard lubrication					润滑油(终生润滑) / Oil (lifetime lubrication)				
F	食品级润滑	Food grade lubrication					润滑油(终生润滑) / Oil (lifetime lubrication)				
	安装位置	Installation position					任意 / Any				
S	标准回程间隙	Standard backlash					< 5				
R	降低回程间隙	Reduced backlash	j _t	arcmin	-				1		
							< 3				2
	抗扭刚度 ⁽²⁾	Torsional stiffness ⁽²⁾	c _G	Nm / arcmin	1,8 - 3,1	4,6 - 7,0	8,6 - 13,5	24,5 - 34,0	1		
							2,3 - 3,6	5,9 - 8,6	11,3 - 16,9	31,5 - 42,5	2
	减速机重量 ⁽²⁾	Gearbox weight ⁽²⁾	m _G	kg	3,3 - 3,4	5,3 - 5,8	11,0 - 11,1	25,3 - 25,9	1		
							4,3 - 4,4	5,6 - 5,7	10,0 - 10,3	23,7 - 24,3	2
S	标准的箱体表面	Standard surface					直角箱体: 铝 - 阳极氧化处理 (黑色) Right angle housing: Aluminum - anodized (black)				
B	喷漆表面	Painted surface					RAL 9005 黑色 RAL 9005 Jet black				
	运行噪音 ⁽³⁾	Running noise ⁽³⁾	Q _G	dB(A)	66	67	68	70			
	基于减速机输入法兰的最大弯矩 ⁽⁴⁾	Max. bending moment based on the gearbox input flange ⁽⁴⁾	M _b	Nm	12	25,5	53	120	1		
							12	12	25,5	53	2

输出轴载荷	Output shaft loads			WPLN070	WPLN090	WPLN115	WPLN142	p ⁽¹⁾
20,000 h 径向力 ⁽⁵⁾⁽⁶⁾	Radial force for 20,000 h ⁽⁵⁾⁽⁶⁾	F _{r20.000h}	N	3200	5200	6000	12500	1
				3200	5500	6000	12500	2
20,000 h 轴向力 ⁽⁵⁾⁽⁶⁾	Axial force for 20,000 h ⁽⁵⁾⁽⁶⁾	F _{a20.000h}		4300	5900	7000	14500	1
				4400	6400	8000	15000	2
30,000 h 径向力 ⁽⁵⁾⁽⁶⁾	Radial force for 30,000 h ⁽⁵⁾⁽⁶⁾	F _{r30.000h}		3200	5200	6000	10900	1
				3200	4800	5400	11400	2
30,000 h 轴向力 ⁽⁵⁾⁽⁶⁾	Axial force for 30,000 h ⁽⁵⁾⁽⁶⁾	F _{a30.000h}		3700	5200	6100	12000	1
				3900	5700	7000	13200	2
最大径向力 ⁽⁶⁾⁽⁷⁾	Maximum radial force ⁽⁶⁾⁽⁷⁾	F _{r Stat}		3200	5200	6000	12500	1
				3200	5500	6000	12500	2
最大轴向力 ⁽⁶⁾⁽⁷⁾	Maximum axial force ⁽⁶⁾⁽⁷⁾	F _{a Stat}		4300	5900	7000	14500	1
				4400	6400	8000	15000	2
20,000 h 倾斜力矩 ⁽⁵⁾⁽⁷⁾	Tilting moment for 20,000 h ⁽⁵⁾⁽⁷⁾	M _{K20.000h}	Nm	322	624	1010	2225	1
				191	383	488	1420	2
30,000 h 倾斜力矩 ⁽⁵⁾⁽⁷⁾	Tilting moment for 30,000 h ⁽⁵⁾⁽⁷⁾	M _{K30.000h}		322	624	1010	1940	1
				191	335	439	1295	2

转动惯量	Moment of inertia			WPLN070	WPLN090	WPLN115	WPLN142	p ⁽¹⁾
转动惯量 ⁽²⁾	Mass moment of inertia ⁽²⁾	J	kgcm ²	0,500 - 0,658	1,013 - 1,387	4,767 - 5,875	15,090 - 20,883	1
				0,498 - 0,642	0,497 - 0,649	1,014 - 1,419	4,807 - 6,387	2

(1) 减速机级数
 (2) 传动比相关的数值可在 Tec Data Finder 中检索 - www.neugart.com
 (3) 距离减速机 1 m 时; 在输入转速为 n₁=3000 min⁻¹ 且无负荷时测得; i=5
 (4) 最大电机重量* (单位: kg) = 0.2 × M_b / 电机长度 (单位: m)
 * 电机重量对称分布
 * 水平和固定的安装位置
 (5) 数据以 n₂=100 min⁻¹ 的输出轴转速为准。
 (6) 以输出轴中心为准
 (7) 更改 T_{2N}, F_r, F_a 以及周期和轴承使用寿命时, 数值存在偏差(部分较高)。利用 NCP 针对应用进行专门设计 - www.neugart.com

(1) Number of stages
 (2) The ratio-dependent values can be retrieved in Tec Data Finder - www.neugart.com
 (3) Sound pressure level from 1 m, measured on input running at n₁=3000 rpm no load; i=5
 (4) Max. motor weight* in kg = 0.2 × M_b / motor length in m
 * with symmetrically distributed motor weight
 * with horizontal and stationary mounting
 (5) These values are based on an output shaft speed of n₂=100 rpm
 (6) Based on center of output shaft
 (7) Other (sometimes higher) values following changes to T_{2N}, F_r, F_a, cycle, and service life of bearing. Application specific configuration with NCP - www.neugart.com

输出扭矩	Output torques			WPLN070	WPLN090	WPLN115	WPLN142	i ⁽¹⁾	p ⁽²⁾
额定输出扭矩 ⁽³⁾⁽⁴⁾	Nominal output torque ⁽³⁾⁽⁴⁾	T _{2N}	Nm	45	90	160	320	4	1
				42	75	140	280	5	
				28	51	91	189	7	
				27	50	90	180	8	
				22	40	75	160	10	
				77	150	300	640	16	2
				77	150	300	800	20	
				65	140	260	700	25	
				60	112	204	364	28	
				77	108	200	360	32	
				65	140	255	455	35	
				65	135	250	450	40	
				65	110	200	375	50	
				40	80	150	450	64	
27	60	125	305	100					
最大输出扭矩 ⁽⁴⁾⁽⁵⁾	Max. output torque ⁽⁴⁾⁽⁵⁾	T _{2max}	Nm	72	144	256	512	4	1
				67	120	224	448	5	
				45	82	145	302	7	
				43	80	144	288	8	
				35	64	120	256	10	
				123	240	480	1024	16	2
				123	240	480	1280	20	
				104	224	416	1120	25	
				96	180	328	580	28	
				123	172	320	576	32	
				104	224	410	725	35	
				104	216	400	720	40	
				104	176	320	600	50	
				64	128	240	720	64	
43	96	200	488	100					

⁽¹⁾ 传动比 (i=n₁/n₂)

⁽²⁾ 减速机级数

⁽³⁾ 利用 NCP 针对应用进行专门设计 – www.neugart.com

⁽⁴⁾ 平键 (代码 "A")时的数值: 针对交变载荷

⁽⁵⁾ 允许输出轴转动30.000转; 参见第 166 页

⁽¹⁾ Ratios (i=n₁/n₂)

⁽²⁾ Number of stages

⁽³⁾ Application specific configuration with NCP – www.neugart.com

⁽⁴⁾ Values for feather key (code "A"): for repeated load

⁽⁵⁾ 30,000 rotations of the output shaft permitted; see page 167

输出扭矩	Output torques			WPLN070	WPLN090	WPLN115	WPLN142	$i^{(1)}$	$p^{(2)}$
急停扭矩 ⁽³⁾	Emergency stop torque ⁽³⁾	T_{2Stop}	Nm	100	200	400	800	4	1
				100	200	400	800	5	
				75	150	300	700	7	
				75	150	300	700	8	
				75	150	300	700	10	2
				150	300	650	1600	16	
				150	300	650	1600	20	
				150	300	650	1600	25	
				120	280	600	1200	28	
				150	300	600	1200	32	
				130	280	650	1500	35	
				150	300	650	1500	40	
				150	300	600	1200	50	
				80	200	380	1000	64	
				80	200	480	750	100	

输入转速	Input speeds			WPLN070	WPLN090	WPLN115	WPLN142	$i^{(1)}$	$p^{(2)}$
T_{2N} 和 S1 时的平均热输入转速 ⁽⁴⁾⁽⁵⁾	Average thermal input speed at T_{2N} and S1 ⁽⁴⁾⁽⁵⁾	n_{1N}	min^{-1}	1800 ⁽⁶⁾	1650 ⁽⁶⁾	1150 ⁽⁶⁾	950 ⁽⁶⁾	4	1
				2000 ⁽⁶⁾	1900 ⁽⁶⁾	1250 ⁽⁶⁾	1000 ⁽⁶⁾	5	
				2350 ⁽⁶⁾	2250 ⁽⁶⁾	1400 ⁽⁶⁾	1200 ⁽⁶⁾	7	
				2350 ⁽⁶⁾	2250 ⁽⁶⁾	1450 ⁽⁶⁾	1200 ⁽⁶⁾	8	
				2500 ⁽⁶⁾	2400 ⁽⁶⁾	1500 ⁽⁶⁾	1300 ⁽⁶⁾	10	2
				1850 ⁽⁶⁾	1800 ⁽⁶⁾	1650 ⁽⁶⁾	1000 ⁽⁶⁾	16	
				2000 ⁽⁶⁾	2100 ⁽⁶⁾	1950 ⁽⁶⁾	1050 ⁽⁶⁾	20	
				2150 ⁽⁶⁾	2250 ⁽⁶⁾	2150 ⁽⁶⁾	1150 ⁽⁶⁾	25	
				2200 ⁽⁶⁾	2250 ⁽⁶⁾	2150 ⁽⁶⁾	1400 ⁽⁶⁾	28	
				2300 ⁽⁶⁾	2300 ⁽⁶⁾	2200 ⁽⁶⁾	1400 ⁽⁶⁾	32	
				2350 ⁽⁶⁾	2300 ⁽⁶⁾	2200 ⁽⁶⁾	1400 ⁽⁶⁾	35	
				2400 ⁽⁶⁾	2300 ⁽⁶⁾	2250 ⁽⁶⁾	1450 ⁽⁶⁾	40	
				2500 ⁽⁶⁾	2450 ⁽⁶⁾	2400 ⁽⁶⁾	1550 ⁽⁶⁾	50	
				2600 ⁽⁶⁾	2950 ⁽⁶⁾	2850 ⁽⁶⁾	1750 ⁽⁶⁾	64	
2700 ⁽⁶⁾	3100 ⁽⁶⁾	3050 ⁽⁶⁾	1900 ⁽⁶⁾	100					
最高机械输入转速 ⁽⁴⁾	Max. mechanical input speed ⁽⁴⁾	n_{1Limit}	min^{-1}	16000	14000	9500	8000		1
				16000	16000	14000	9500		2

⁽¹⁾ 传动比 ($i=n_1/n_2$)

⁽²⁾ 减速机级数

⁽³⁾ 允许 1000 次

⁽⁴⁾ 利用 NCP 针对应用设计转速 – www.neugart.com

⁽⁵⁾ 定义请参见第 166 页

⁽⁶⁾ 在 50% T_{2N} 输出和 S1 模式下的平均热输入转速

⁽¹⁾ Ratios ($i=n_1/n_2$)

⁽²⁾ Number of stages

⁽³⁾ Permitted 1000 times

⁽⁴⁾ Application-specific speed configurations with NCP – www.neugart.com

⁽⁵⁾ See page 167 for the definition

⁽⁶⁾ Average thermal input speed at 50% T_{2N} and S1

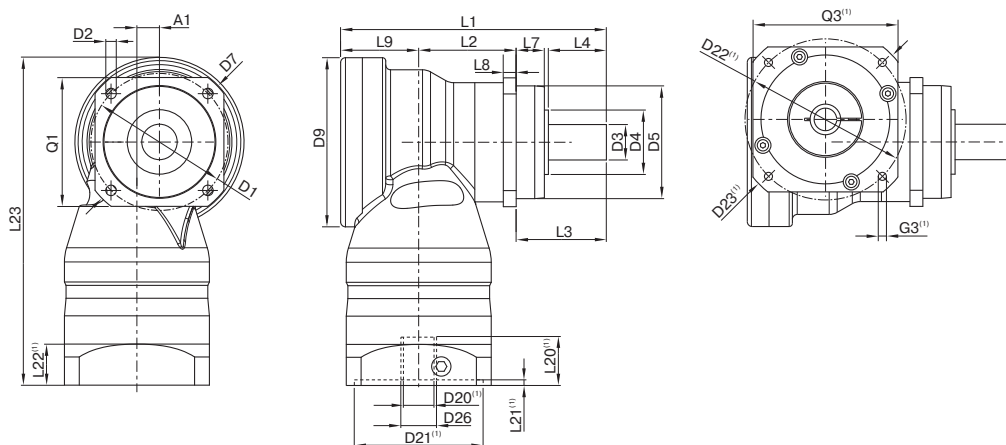

图示为带平键的 WPLN090 / 1 级 / 光滑输出轴 / 19 mm 锁紧系统 / 适配电机法兰 - 2 件式 - 圆形通用法兰 / B5 电机法兰类型
 Drawing corresponds to a WPLN090 / 1-stage / smooth output shaft / 19 mm clamping system / motor adaptation - 2-part - round universal flange / B5 flange type motor

(1) 具体尺寸视电机/减速机法兰而定。可以在 www.neugart.com 下 Tec Data Finder 中针对每个电机适配电机特有的输入法兰几何尺寸。
 (1) The dimensions vary with the motor/gearbox flange. The input flange dimensions can be retrieved for each specific motor in Tec Data Finder at www.neugart.com

几何尺寸 ⁽²⁾	Geometry ⁽²⁾			WPLN070	WPLN090	WPLN115	WPLN142	p ⁽³⁾	Code
轴向偏差	Axis offset	A1		10	14	20	26	1	
				10	10	14	20	2	
输出端安装孔节圆直径	Pitch circle diameter output	D1		68 - 75	85	120	165		
输出端安装孔直径	Mounting bore output	D2	4x	5,5	6,5	9,0	11,0		
输出轴直径	Shaft diameter output	D3	k6	16	22	32	40		
输出轴轴肩直径	Shaft collar output	D4		30	40	45	70	1	
				35	40	45	70	2	
输出端定位凸台直径	Centering diameter output	D5	g7	60	70	90	130		
输出法兰对角线尺寸	Diagonal dimension output	D7		92	100	140	185		
最大直径	Max. diameter	D9		86	105	120	170	1	
				86	86	105	120	2	
输出端法兰外方	Flange cross section output	Q1	■	70	80	110	142		
总长	Total length	L1		137,5	165	218	273	1	
				185	207	248,5	342,5	2	
箱体长度	Housing length	L2		46,5	60,5	73,5	76	1	
				94	108	112	176	2	
输出轴轴长	Shaft length output	L3		48	56	88	110		
输出端定位凸台深度	Centering depth output	L7		18	17,5	28	28	1	
				19	17,5	28	28	2	
输出端法兰厚度	Flange thickness output	L8		7	8	10	12		
偏差距离	Offset length	L9		43	48,5	56,5	87	1	
				43	43	48,5	56,5	2	
最小总高度	Min. overall height	L23		179,0	203,5	247,5	318,0	1	
				179,0	182,5	210,0	258,5	2	
电机轴直径j6/k6	Motor shaft diameter j6/k6	D20		更多信息见第 163/164 页 More information on page 163/164					
输入端锁紧系统直径	Clamping system diameter input	D26							
带平键的输出轴 (DIN 6885-1)	Output shaft with feather key (DIN 6885-1)			A 5x5x25	A 6x6x28	A 10x8x50	A 12x8x65		A
平键宽度 (DIN 6885-1)	Feather key width (DIN 6885-1)	B1		5	6	10	12		
含平键在内的轴高 (DIN 6885-1)	Shaft height including feather key (DIN 6885-1)	H1		18	24,5	35	43		
到轴肩的距离	Shaft length from shoulder	L4		28	36	58	80		
平键长度	Feather key length	L5		25	28	50	65		
到轴端的距离	Distance from shaft end	L6		2	4	4	8		
中心孔 (DIN 332, DR 形)	Center hole (DIN 332, type DR)	C		M5x12,5	M8x19	M12x28	M16x36		
光滑输出轴	Smooth output shaft								B
到轴肩的距离	Shaft length from shoulder	L4		28	36	58	80		
花键输出轴 (DIN 5480)	Splined output shaft (DIN 5480)			W16x0,8 x18x6m	W22x1,25 x16x6m	W32x1,25 x24x6m	W40x2,0 x18x6m		C
花键或键槽的长度	Width of gearing	L _v		15	15	15	20		
输出轴轴肩直径	Shaft collar output	L3		48	56	88	110		
到轴肩的距离	Shaft length from shoulder	L4		26	26	26	40		
中心孔 (DIN 332, DR 形)	Center hole (DIN 332, type DR)	C		M5x12,5	M8x19	M12x28	M16x36		

(2) 所有的尺寸单位为mm
 (3) 减速机级数

(2) Dimensions in mm
 (3) Number of stages



1级
1-stage

2级
2-stage

WPSFN

最短的准双曲面齿轮直角行星减速机，带有法兰输出轴和空心轴

我们的 **WPSFN** 凭借其标准法兰接口，可以特别轻松迅速地集成到系统里，而且具备很高的抗扭刚度。它凭借准双曲面齿轮、斜齿行星级、以及优化的同步，达到最佳的表面质量。最短的直角高精度行星减速机，集成了空心轴的1级设计，为您提供了新的设计解决方案。

The shortest hypoid-toothed right angle gearbox with flange output shaft and hollow shaft

Our **WPSFN** is particularly easy and quick to integrate thanks to its standardized flange interface and offers high torsional rigidity. With its hypoid gearing, as well as the helical-toothed planetary stage, it achieves optimal synchronization for best surface qualities. The shortest right-angle precision gearbox, in a single-stage design with integrated hollow shaft, offers you new design solutions.

额定扭矩 Nominal output torque	22 - 625 Nm
径向力 Radial force	2150 - 12000 N
轴向力 Axial force	4200 - 9500 N
回程间隙 Torsional backlash	3 - 5 arcmin
防护等级 Protection class	IP65

结构尺寸 Frame sizes



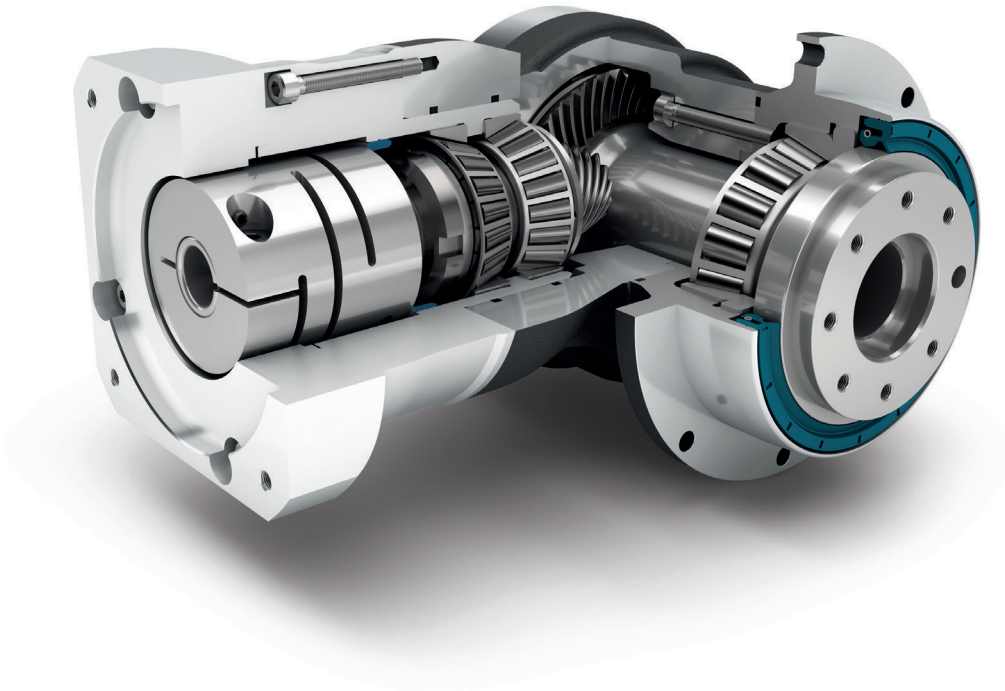

精密型
Precision Line



旋转方向 反方向
Counterdirectional rotation

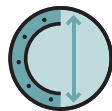

圆形特大号输出法兰
Extra large round type output flange



径向轴密封
Rotary shaft seal



空心轴 (1级)
Hollow shaft (1-stage)



可选: 装有小齿轮的高精度减速机
132页
Option: Planetary gearbox with
mounted pinion on page 132



直角型减速机
Right angle gearbox



准双曲面齿轮 直角箱
Hypoid gear right angle stage



配有预紧的角接触滚子轴承
Preloaded angular contact roller bearings



法兰输出轴 (按 ISO 9409-1 标准)
Flange output shaft (ISO 9409-1)



可选: 降低回程间隙 (2级)
Option: Reduced backlash (2-stage)



可选: 喷漆表面
—RAL 9005 黑色
Option: Painted surface
—RAL 9005 Jet black

技术特点的详细解释, 请从第173页读起。
Detailed explanations of the technical features starting on page 173.

Code	减速机参数	Gearbox characteristics			WPSFN064	WPSFN090	WPSFN110	WPSFN140	p ⁽¹⁾		
	使用寿命 (L _{10h})	Service life (L _{10h})	t _L	h	20.000						
	T _{2N} × 0,88 时的使用寿命	Service life at T _{2N} × 0,88			30.000						
	满载时效率 ⁽²⁾	Efficiency at full load ⁽²⁾	η	%	94				1		
	最低工作温度	Min. operating temperature	T _{min}	°C	-25						
	最高工作温度	Max. operating temperature	T _{max}		90						
	防护等级	Protection class					IP65				
S	标准润滑	Standard lubrication					润滑油(终生润滑) / Oil (lifetime lubrication)				
F	食品级润滑	Food grade lubrication					润滑油(终生润滑) / Oil (lifetime lubrication)				
	安装位置	Installation position					任意 / Any				
S	标准回程间隙	Standard backlash					< 5				
R	降低回程间隙	Reduced backlash	j _t	arcmin	-				1		
							< 3				2
	抗扭刚度 ⁽²⁾	Torsional stiffness ⁽²⁾	c _G	Nm / arcmin	1,9 - 2,6	4,0 - 5,5	10,1 - 13,5	26,0 - 34,5	1		
							5,3 - 6,9	15,3 - 20,5	33,5 - 44,0	85,0 - 111,0	2
	减速机重量 ⁽²⁾	Gearbox weight ⁽²⁾	m _G	kg	3,4 - 3,5	6,5 - 6,9	11,4 - 11,5	24,8 - 25,3	1		
							3,8 - 3,9	5,4 - 5,6	8,7 - 9,0	18,3 - 18,8	2
S	标准的箱体表面	Standard surface					直角箱体: 铝 - 阳极氧化处理 (黑色) Right angle housing: Aluminum - anodized (black)				
B	喷漆表面	Painted surface					RAL 9005 黑色 RAL 9005 Jet black				
	运行噪音 ⁽³⁾	Running noise ⁽³⁾	Q _G	dB(A)	66	67	68	70			
	基于减速机输入法兰的最大弯矩 ⁽⁴⁾	Max. bending moment based on the gearbox input flange ⁽⁴⁾	M _b	Nm	12	25,5	53	120	1		
							12	12	25,5	53	2

输出轴载荷	Output shaft loads			WPSFN064	WPSFN090	WPSFN110	WPSFN140	p ⁽¹⁾
20,000 h 径向力 ⁽⁵⁾⁽⁶⁾	Radial force for 20,000 h ⁽⁵⁾⁽⁶⁾	F _{r20.000h}	N	2400	4400	5500	12000	1
				2150	3950	4900	12000	2
20,000 h 轴向力 ⁽⁵⁾⁽⁶⁾	Axial force for 20,000 h ⁽⁵⁾⁽⁶⁾	F _{a20.000h}		4200	7200	9500	8500	1
				4300	8200	9500	8500	2
30,000 h 径向力 ⁽⁵⁾⁽⁶⁾	Radial force for 30,000 h ⁽⁵⁾⁽⁶⁾	F _{r30.000h}		2100	3900	4800	11000	1
				1900	3500	4350	11000	2
30,000 h 轴向力 ⁽⁵⁾⁽⁶⁾	Axial force for 30,000 h ⁽⁵⁾⁽⁶⁾	F _{a30.000h}		3700	6300	8400	7500	1
				3800	7200	8400	7500	2
最大径向力 ⁽⁶⁾⁽⁷⁾	Maximum radial force ⁽⁶⁾⁽⁷⁾	F _{r Stat}		2400	4400	5500	12000	1
				2150	3950	4900	12000	2
最大轴向力 ⁽⁶⁾⁽⁷⁾	Maximum axial force ⁽⁶⁾⁽⁷⁾	F _{a Stat}		4200	7200	9500	8500	1
				4300	8200	9500	8500	2
20,000 h 倾斜力矩 ⁽⁵⁾⁽⁷⁾	Tilting moment for 20,000 h ⁽⁵⁾⁽⁷⁾	M _{K20.000h}	Nm	200	484	689	1989	1
				132	326	475	1030	2
30,000 h 倾斜力矩 ⁽⁵⁾⁽⁷⁾	Tilting moment for 30,000 h ⁽⁵⁾⁽⁷⁾	M _{K30.000h}		175	429	601	1823	1
				117	289	422	944	2

转动惯量	Moment of inertia			WPSFN064	WPSFN090	WPSFN110	WPSFN140	p ⁽¹⁾
转动惯量 ⁽²⁾	Mass moment of inertia ⁽²⁾	J	kgcm ²	0,502 - 0,672	1,046 - 1,591	4,857 - 6,435	15,220 - 21,693	1
				0,497 - 0,642	0,497 - 0,659	1,015 - 1,452	4,810 - 6,449	2

(1) 减速机级数
 (2) 传动比相关的数值可在 Tec Data Finder 中检索 - www.neugart.com
 (3) 距离减速机 1 m 时; 在输入转速为 n₁=3000 min⁻¹ 且无负荷时测得; i=5
 (4) 最大电机重量* (单位: kg) = 0.2 × M_b / 电机长度 (单位: m)
 * 电机重量对称分布
 * 水平和固定的安装位置
 (5) 数据以 n₂=100 min⁻¹ 的输出轴转速为准。
 (6) 以输出轴中心为准
 (7) 更改 T_{2N}, F_r, F_a 以及周期和轴承使用寿命时, 数值存在偏差(部分较高)。利用 NCP 针对应用进行专门设计 - www.neugart.com

(1) Number of stages
 (2) The ratio-dependent values can be retrieved in Tec Data Finder - www.neugart.com
 (3) Sound pressure level from 1 m, measured on input running at n₁=3000 rpm no load; i=5
 (4) Max. motor weight* in kg = 0.2 × M_b / motor length in m
 * with symmetrically distributed motor weight
 * with horizontal and stationary mounting
 (5) These values are based on an output shaft speed of n₂=100 rpm
 (6) Based on the end of the output shaft
 (7) Other (sometimes higher) values following changes to T_{2N}, F_r, F_a, cycle, and service life of bearing. Application specific configuration with NCP - www.neugart.com

输出扭矩	Output torques			WPSFN064	WPSFN090	WPSFN110	WPSFN140	i ⁽¹⁾	p ⁽²⁾
额定输出扭矩 ⁽³⁾	Nominal output torque ⁽³⁾	T _{2N}	Nm	45	90	160	320	4	1
				42	75	140	280	5	
				28	51	91	189	7	
				27	50	90	180	8	
				22	40	75	160	10	
				62	130	310	625	16	2
				62	130	300	560	20	
				60	120	255	540	25	
				62	112	204	364	28	
				62	108	200	360	32	
				60	123	255	455	35	
				60	123	250	450	40	
				60	110	200	375	50	
				37	78	175	355	70	
28	59	140	305	100					
最大输出扭矩 ⁽⁴⁾	Max. output torque ⁽⁴⁾	T _{2max}	Nm	72	144	256	512	4	1
				67	120	224	448	5	
				45	82	145	302	7	
				43	80	144	288	8	
				35	64	120	256	10	
				99	210	502	1003	16	2
				99	210	480	896	20	
				96	197	408	864	25	
				99	180	328	580	28	
				99	172	320	576	32	
				96	197	410	725	35	
				96	197	400	720	40	
				96	175	320	600	50	
				59	125	280	568	70	
45	94	224	488	100					

⁽¹⁾ 传动比 (i=n₁/n₂)

⁽²⁾ 减速机级数

⁽³⁾ 利用 NCP 针对应用进行专门设计 – www.neugart.com

⁽⁴⁾ 允许输出轴转动30.000转; 参见第 166 页

⁽¹⁾ Ratios (i=n₁/n₂)

⁽²⁾ Number of stages

⁽³⁾ Application specific configuration with NCP – www.neugart.com

⁽⁴⁾ 30,000 rotations of the output shaft permitted; see page 167

输出扭矩	Output torques			WPSFN064	WPSFN090	WPSFN110	WPSFN140	i ⁽¹⁾	p ⁽²⁾
急停扭矩 ⁽³⁾	Emergency stop torque ⁽³⁾	T _{2Stop}	Nm	100	200	400	800	4	1
				100	200	400	800	5	
				75	150	300	700	7	
				75	150	300	700	8	
				75	150	300	700	10	2
				150	300	650	1600	16	
				150	300	650	1600	20	
				150	300	650	1650	25	
				150	300	600	1200	28	
				150	300	600	1200	32	
				150	300	650	1500	35	
				150	300	650	1500	40	
				150	300	650	1500	50	
				80	175	340	1300	70	
				90	200	480	600	100	

输入转速	Input speeds			WPSFN064	WPSFN090	WPSFN110	WPSFN140	i ⁽¹⁾	p ⁽²⁾
T _{2N} 和 S1 时的平均热输入转速 ⁽⁴⁾⁽⁵⁾	Average thermal input speed at T _{2N} and S1 ⁽⁴⁾⁽⁵⁾	n _{1N}	min ⁻¹	1850 ⁽⁶⁾	1650 ⁽⁶⁾	1100 ⁽⁶⁾	1000 ⁽⁶⁾	4	1
				2050 ⁽⁶⁾	1900 ⁽⁶⁾	1200 ⁽⁶⁾	1100 ⁽⁶⁾	5	
				2450 ⁽⁶⁾	2350 ⁽⁶⁾	1450 ⁽⁶⁾	1300 ⁽⁶⁾	7	
				2500 ⁽⁶⁾	2400 ⁽⁶⁾	1450 ⁽⁶⁾	1300 ⁽⁶⁾	8	
				2650 ⁽⁶⁾	2550 ⁽⁶⁾	1500 ⁽⁶⁾	1400 ⁽⁶⁾	10	2
				2250 ⁽⁶⁾	2100 ⁽⁶⁾	1750 ⁽⁶⁾	1400 ⁽⁶⁾	16	
				2400 ⁽⁶⁾	2300 ⁽⁶⁾	2000 ⁽⁶⁾	1350 ⁽⁶⁾	20	
				2500 ⁽⁶⁾	2600 ⁽⁶⁾	2300 ⁽⁶⁾	1450 ⁽⁶⁾	25	
				2550 ⁽⁶⁾	2650 ⁽⁶⁾	2400 ⁽⁶⁾	1650 ⁽⁶⁾	28	
				2550 ⁽⁶⁾	2700 ⁽⁶⁾	2450 ⁽⁶⁾	1650 ⁽⁶⁾	32	
				2750 ⁽⁶⁾	2850 ⁽⁶⁾	2450 ⁽⁶⁾	1650 ⁽⁶⁾	35	
				2800 ⁽⁶⁾	2750 ⁽⁶⁾	2500 ⁽⁶⁾	1650 ⁽⁶⁾	40	
				2750 ⁽⁶⁾	2900 ⁽⁶⁾	2650 ⁽⁶⁾	1750 ⁽⁶⁾	50	
				3000 ⁽⁶⁾	3300 ⁽⁶⁾	3000 ⁽⁶⁾	1950 ⁽⁶⁾	70	
				3050 ⁽⁶⁾	3600 ⁽⁶⁾	3300 ⁽⁶⁾	2150 ⁽⁶⁾	100	
				最高机械输入转速 ⁽⁴⁾	Max. mechanical input speed ⁽⁴⁾	n _{1Limit}	min ⁻¹	16000	14000
16000	16000	14000	9500						2

⁽¹⁾ 传动比 (i=n₁/n₂)

⁽²⁾ 减速级数

⁽³⁾ 允许 1000 次

⁽⁴⁾ 利用 NCP 针对应用设计转速 – www.neugart.com

⁽⁵⁾ 定义请参见第 166 页

⁽⁶⁾ 在 50% T_{2N} 输出和 S1 模式下的平均热输入转速

⁽¹⁾ Ratios (i=n₁/n₂)

⁽²⁾ Number of stages

⁽³⁾ Permitted 1000 times

⁽⁴⁾ Application-specific speed configurations with NCP – www.neugart.com

⁽⁵⁾ See page 167 for the definition

⁽⁶⁾ Average thermal input speed at 50% T_{2N} and S1

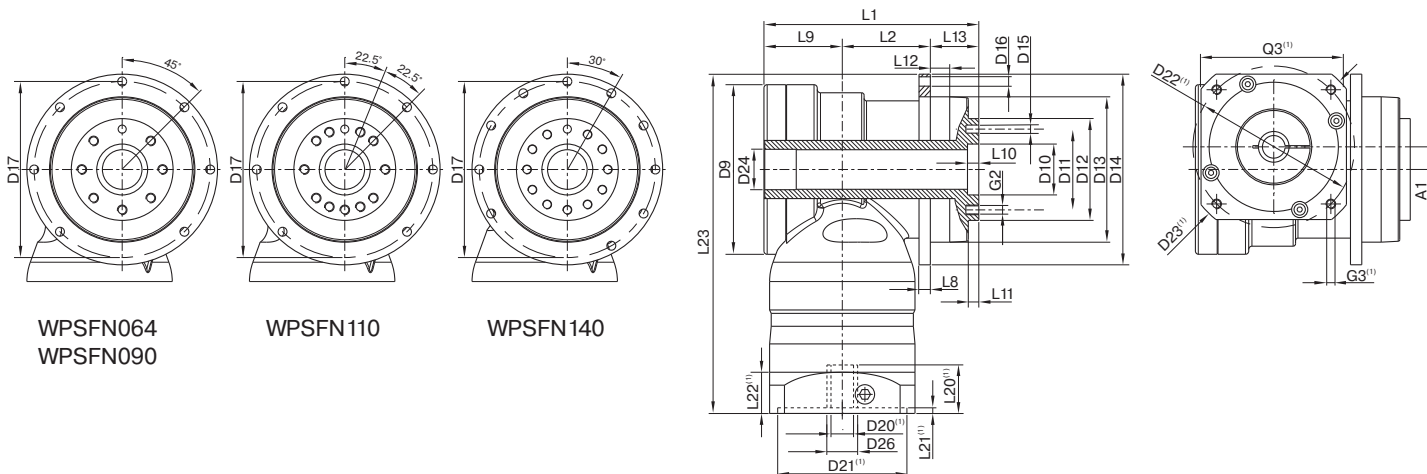

WPSFN064
WPSFN090

WPSFN110

WPSFN140

图示为带平键的 WPLN090 / 1 级 / 光滑输出轴 / 19 mm 锁紧系统 / 适配电机法兰 - 2 件式 - 圆形通用法兰 / B5 电机法兰类型
Drawing corresponds to a WPSFN090 / 1-stage / flange hollow output shaft / 19 mm clamping system / motor adaptation - 2-part - round universal flange / B5 flange type motor

(1) 具体尺寸视电机/减速机法兰而定。可以在 www.neugart.com 下 Tec Data Finder 中针对每个电机适配电机特有的输入法兰几何尺寸。
(1) The dimensions vary with the motor/gearbox flange. The input flange dimensions can be retrieved for each specific motor in Tec Data Finder at www.neugart.com

几何尺寸 ⁽²⁾	Geometry ⁽²⁾			WPSFN064	WPSFN090	WPSFN110	WPSFN140	p ⁽³⁾	Code
轴向偏差	Axis offset	A1		10	14	20	26	1	
				10	10	14	20	2	
最大直径	Max. diameter	D9		86	105	120	170	1	
				86	86	105	120	2	
输出端定位凹槽直径	Centering diameter output shaft	D10	H7	20	31,5	40	50		
输出端安装孔节圆直径	Pitch circle diameter output shaft	D11		31,5	50	63	80		
输出轴定位凸台直径	Centering diameter output shaft	D12	h7	40	63	80	100		
法兰输出轴的直径	Flange output shaft diameter	D13		64	90	110	140		
输出法兰直径	Flange diameter output	D14		86	118	145	179		
输出端安装孔直径	Mounting bore output	D16		4,5 7x45°	5,5 7x45°	5,5 7x45°	6,6 10x30°	1	
				4,5 8x45°	5,5 8x45°	5,5 8x45°	6,6 12x30°	2	
输出法兰安装孔节圆直径	Pitch circle diameter output flange	D17		79	109	135	168		
最小总长	Min. total length	L1		104,5	132	153,5	201,5	1	
				122,5	139,5	154	224	2	
箱体长度	Housing length	L2		42	53,5	68	76,5	1	
				59,5	66,5	76,5	129,5	2	
输出端法兰厚度	Flange thickness output	L8		4	7	8	10		
偏差距离	Offset length	L9		43	48,5	56,5	87	1	
				43	43	48,5	56,5	2	
输出轴定位凸台深度	Centering depth output shaft	L10		4,5	6,5	6,5	6,5		
				L11	3	6	6	6	
输出法兰定位凸台深度	Centering depth output flange	L12		10	12	12	14		
输出法兰长度	Output flange length	L13		19,5	30,0	29,0	38,0		
最小总高度	Min. overall height	L23		179	210	260	323	1	
				179	195	223,5	277	2	
电机轴直径j6/k6	Motor shaft diameter j6/k6	D20		更多信息见第 163/164 页					
输入端锁紧系统直径	Clamping system diameter input	D26		More information on page 163/164					
带有定位销孔的法兰输出轴 (ISO 9409-1)	Flange output hollow shaft with dowel hole (ISO 9409-1)								
配合销孔 x 深度	Dowel hole x depth	D15	H7	5x5	6x6	6x6	8x8	1	H
空心轴直径	Hollow shaft diameter	D24		17	25	35	50		
数量 x 螺纹 x 深度	Number x thread x depth	G2		7 x M5x7	7 x M6x10	11 x M6x12	11 x M8x15		
法兰输出轴 (相似的 ISO 9409-1)	Flange output shaft (similar ISO 9409-1)							2	D
数量 x 螺纹 x 深度	Number x thread x depth	G2		8 x M5x7	8 x M6x10	12 x M6x12	12 x M8x15		
带有配合销孔的法兰输出轴 (ISO 9409-1)	Flange output shaft with dowel hole (ISO 9409-1)							2	E
配合销孔 x 深度	Dowel hole x depth	D15	H7	5x5	6x6	6x6	8x8		
数量 x 螺纹 x 深度	Number x thread x depth	G2		7 x M5x7	7 x M6x10	11 x M6x12	11 x M8x15		

(2) 所有的尺寸单位为mm
(3) 减速级数

(2) Dimensions in mm
(3) Number of stages



WGN

带有空心轴的准双曲面齿轮直角行星减速机 —— 低噪音，压入式安装

我们的 **WGN** 是一种运行噪音特别轻的直角式空心轴减速机。与此同时，准双曲面齿轮提高了您的工件表面质量。借助胀紧套可以直接连接应用 —— 这样做简单、安全，而且为您的设计节省了更多空间。

The hypoid-toothed right-angle gearbo with hollow shaft – low-noise and force-fit mounting

Our **WGN** is the right-angle hollow shaft gearbox that operates particularly quietly. At the same time, the hypoid gearing increases the quality of the surface of your workpiece. With a shrink disc, it can be connected directly to the application - this is uncomplicated, safe and opens up new design possibilities.

额定扭矩

Nominal output torque **22 - 320 Nm**

径向力

Radial force **2700 - 10000 N**

轴向力

Axial force **4300 - 14500 N**

回程间隙

Torsional backlash **5 arcmin**

防护等级

Protection class **IP65**

结构尺寸

Frame sizes

70

90

115

142

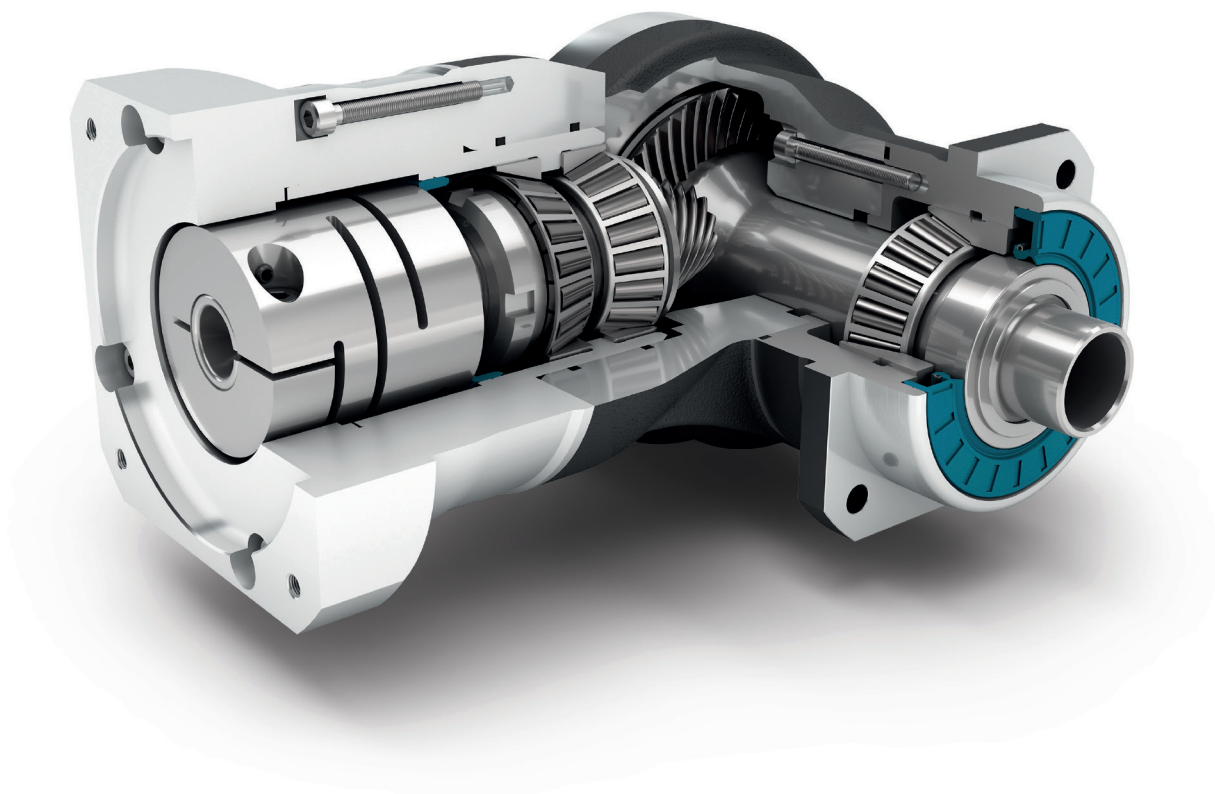

精密型
Precision Line



旋转方向 反方向
Counterdirectional rotation



正方形输出法兰
Square type output flange



径向轴密封
Rotary shaft seal



夹紧系统的空心轴，带有胀紧套
Hollow shaft for clamping system
with shrink disc



直角型减速机
Right angle gearbox



准双曲面齿轮 直角箱
Hypoid gear right angle stage



配有预紧的圆锥滚子轴承
Preloaded tapered roller bearings



输出端带有超长定心环
Extra long centering collar



可选：喷漆表面
——RAL 9005 黑色
Option: Painted surface
- RAL 9005 Jet black

技术特点的详细解释，请从第173页读起。
Detailed explanations of the technical features starting on page 173.

Code	减速机参数	Gearbox characteristics			WGN070	WGN090	WGN115	WGN142	p ⁽¹⁾
	使用寿命 (L _{10h})	Service life (L _{10h})	t _L	h	20.000				
	T _{2N} × 0,88 时的使用寿命	Service life at T _{2N} × 0,88			30.000				
	满载时效率 ⁽²⁾	Efficiency at full load ⁽²⁾	η	%	95				
	最低工作温度	Min. operating temperature	T _{min}	°C	-25				
	最高工作温度	Max. operating temperature	T _{max}		90				
	防护等级	Protection class			IP65				
S	标准润滑	Standard lubrication			润滑油(终生润滑) / Oil (lifetime lubrication)				
F	食品级润滑	Food grade lubrication			润滑油(终生润滑) / Oil (lifetime lubrication)				
	安装位置	Installation position			任意 / Any				
S	标准回程间隙	Standard backlash	j _t	arcmin	< 5				
R	降低回程间隙	Reduced backlash			-				
	抗扭刚度 ⁽²⁾	Torsional stiffness ⁽²⁾	c _g	Nm / arcmin	1,6 - 2,2	4,2 - 5,7	9,2 - 12,4	23,5 - 31,5	
	减速机重量 ⁽²⁾	Gearbox weight ⁽²⁾	m _G	kg	3,2	5,1 - 5,5	10,7 - 10,8	22,9 - 23,5	
S	标准的箱体表面	Standard surface			直角箱体: 铝 - 阳极氧化处理 (黑色) Right angle housing: Aluminum - anodized (black)				
B	喷漆表面	Painted surface			RAL 9005 黑色 RAL 9005 Jet black				
	运行噪音 ⁽³⁾	Running noise ⁽³⁾	Q _g	dB(A)	66	67	68	70	
	基于减速机输入法兰的最大弯矩 ⁽⁴⁾	Max. bending moment based on the gearbox input flange ⁽⁴⁾	M _b	Nm	12	25,5	53	120	

输出轴载荷	Output shaft loads				WGN070	WGN090	WGN115	WGN142	p ⁽¹⁾
20,000 h 径向力 ⁽⁵⁾⁽⁶⁾	Radial force for 20,000 h ⁽⁵⁾⁽⁶⁾	F _{r20.000h}	N		2700	4000	6500	10000	
20,000 h 轴向力 ⁽⁵⁾⁽⁶⁾	Axial force for 20,000 h ⁽⁵⁾⁽⁶⁾	F _{a20.000h}		4300	5900	7000	14500		
30,000 h 径向力 ⁽⁵⁾⁽⁶⁾	Radial force for 30,000 h ⁽⁵⁾⁽⁶⁾	F _{r30.000h}		2700	4000	6500	10000		
30,000 h 轴向力 ⁽⁵⁾⁽⁶⁾	Axial force for 30,000 h ⁽⁵⁾⁽⁶⁾	F _{a30.000h}		3700	5200	6100	12000		
最大径向力 ⁽⁶⁾⁽⁷⁾	Maximum radial force ⁽⁶⁾⁽⁷⁾	F _{r Stat}		2700	4000	6500	10000		
最大轴向力 ⁽⁶⁾⁽⁷⁾	Maximum axial force ⁽⁶⁾⁽⁷⁾	F _{a Stat}		4300	5900	7000	14500		
20,000 h 倾斜力矩 ⁽⁵⁾⁽⁷⁾	Tilting moment for 20,000 h ⁽⁵⁾⁽⁷⁾	M _{K20.000h}	Nm		253	442	970	1505	
30,000 h 倾斜力矩 ⁽⁵⁾⁽⁷⁾	Tilting moment for 30,000 h ⁽⁵⁾⁽⁷⁾	M _{K30.000h}		253	442	970	1505		

转动惯量	Moment of inertia				WGN070	WGN090	WGN115	WGN142	p ⁽¹⁾
转动惯量 ⁽²⁾	Mass moment of inertia ⁽²⁾	J	kgcm ²		0,502 - 0,834	1,018 - 1,417	4,805 - 6,111	12,934 - 18,905	

(1) 减速机级数
 (2) 传动比相关的数值可在 Tec Data Finder 中检索 - www.neugart.com
 (3) 距离减速机 1 m 时; 在输入转速为 n₁=3000 min⁻¹ 且无负荷时测得; i=5
 (4) 最大电机重量* (单位: kg) = 0.2 × M_b / 电机长度 (单位: m)
 * 电机重量对称分布
 * 水平和固定的安装位置
 (5) 数据以 n₂=100 min⁻¹ 的输出轴转速为准。
 (6) 以输出轴中心为准
 (7) 更改 T_{2N}, F_r, F_a 以及周期和轴承使用寿命时, 数值存在偏差(部分较高)。利用 NCP 针对应用进行专门设计 - www.neugart.com

(1) Number of stages
 (2) The ratio-dependent values can be retrieved in Tec Data Finder - www.neugart.com
 (3) Sound pressure level from 1 m, measured on input running at n₁=3000 rpm no load; i=5
 (4) Max. motor weight* in kg = 0.2 × M_b / motor length in m
 * with symmetrically distributed motor weight
 * with horizontal and stationary mounting
 (5) These values are based on an output shaft speed of n₂=100 rpm
 (6) Based on center of output shaft
 (7) Other (sometimes higher) values following changes to T_{2N}, F_r, F_a, cycle, and service life of bearing. Application specific configuration with NCP - www.neugart.com

输出扭矩	Output torques			WGN070	WGN090	WGN115	WGN142	i ⁽¹⁾	p ⁽²⁾
额定输出扭矩 ⁽³⁾	Nominal output torque ⁽³⁾	T _{2N}	Nm	45	70	140	320	4	1
				42	70	140	280	5	
				28	51	91	189	7	
				27	50	90	180	8	
				22	40	75	160	10	
最大输出扭矩 ⁽⁴⁾	Max. output torque ⁽⁴⁾	T _{2max}	Nm	72	112	224	512	4	
				67	112	224	448	5	
				45	82	145	302	7	
				43	80	144	288	8	
				35	64	120	256	10	
急停扭矩 ⁽⁵⁾	Emergency stop torque ⁽⁵⁾	T _{2Stop}	Nm	100	200	400	800	4	
				100	200	400	800	5	
				75	150	300	700	7	
				75	150	300	700	8	
				75	150	300	700	10	

输入转速	Input speeds			WGN070	WGN090	WGN115	WGN142	i ⁽¹⁾	p ⁽²⁾
T _{2N} 和 S1 时的平均热输入转速 ⁽⁴⁾⁽⁵⁾	Average thermal input speed at T _{2N} and S1 ⁽⁴⁾⁽⁵⁾	n _{1N}	min ⁻¹	1750 ⁽⁶⁾	1700 ⁽⁶⁾	1150 ⁽⁶⁾	950 ⁽⁶⁾	4	1
				1900 ⁽⁶⁾	1850 ⁽⁶⁾	1200 ⁽⁶⁾	1000 ⁽⁶⁾	5	
				2250 ⁽⁶⁾	2200 ⁽⁶⁾	1400 ⁽⁶⁾	1200 ⁽⁶⁾	7	
				2300 ⁽⁶⁾	2200 ⁽⁶⁾	1400 ⁽⁶⁾	1200 ⁽⁶⁾	8	
				2400 ⁽⁶⁾	2350 ⁽⁶⁾	1500 ⁽⁶⁾	1300 ⁽⁶⁾	10	
最高机械输入转速 ⁽⁴⁾	Max. mechanical input speed ⁽⁴⁾	n _{1Limit}	min ⁻¹	16000	14000	9500	8000		

(1) 传动比 (i=n₁/n₂)
 (2) 减速机级数
 (3) 利用 NCP 针对应用进行专门设计 – www.neugart.com
 (4) 允许输出轴转动30.000转; 参见第 166 页
 (5) 允许 1000 次
 (6) 利用 NCP 针对应用设计转速 – www.neugart.com
 (7) 定义请参见第 166 页
 (8) 在 50% T_{2N} 输出和 S1 模式下的平均热输入转速

(1) Ratios (i=n₁/n₂)
 (2) Number of stages
 (3) Application specific configuration with NCP – www.neugart.com
 (4) 30,000 rotations of the output shaft permitted; see page 167
 (5) Permitted 1000 times
 (6) Application-specific speed configurations with NCP – www.neugart.com
 (7) See page 167 for the definition
 (8) Average thermal input speed at 50% T_{2N} and S1

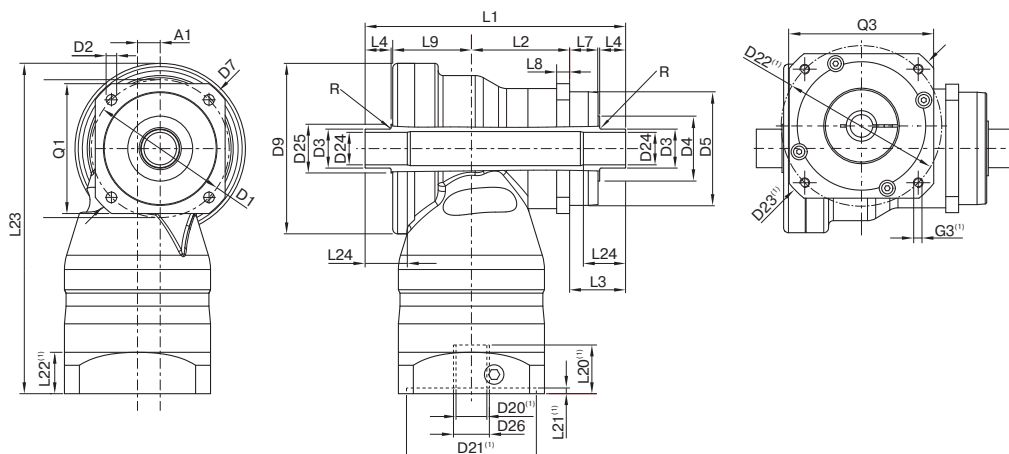

图示为带平键的 WGN090 / 1 级 / 双侧空心输出轴 / 19 mm 锁紧系统 / 适配电机法兰 - 2 件式 - 圆形通用法兰 / B5 电机法兰类型
 Drawing corresponds to a WGN090 / 1-stage / hollow output shaft on both sides / 19 mm clamping system / motor adaptation - 2-part - round universal flange / B5 flange type motor

(1) 具体尺寸视电机/减速机法兰而定。可以在 www.neugart.com 下 Tec Data Finder 中针对每个电机适配电机特有的输入法兰几何尺寸。
 (1) The dimensions vary with the motor/gearbox flange. The input flange dimensions can be retrieved for each specific motor in Tec Data Finder at www.neugart.com

几何尺寸 ⁽²⁾	Geometry ⁽²⁾			WGN070	WGN090	WGN115	WGN142	p ⁽³⁾	Code		
轴向偏差	Axis offset	A1		10	14	20	26	1			
输出端安装孔节圆直径	Pitch circle diameter output	D1		68 - 75	85	120	165				
输出端安装孔直径	Mounting bore output	D2	4x	5,5	6,5	9,0	11,0				
输出轴直径	Shaft diameter output	D3	h8	18	24	36	50				
输出轴轴肩直径	Shaft collar output	D4		30	34	45	70				
输出端定位凸台直径	Centering diameter output	D5	g7	60	70	90	130				
输出法兰对角线尺寸	Diagonal dimension output	D7		92	100	140	185				
最大直径	Max. diameter	D9		86	105	120	170				
输出端法兰外方	Flange cross section output	Q1	■	70	80	110	142				
箱体长度	Housing length	L2		46,5	60,5	73,5	76				
输出轴轴长	Shaft length output	L3		33	34,5	48	54				
输出端定位凸台深度	Centering depth output	L7		18	17,5	27	28				
输出端法兰厚度	Flange thickness output	L8		7	8	10	12				
偏差距离	Offset length	L9		43	48,5	56,5	87				
最小总高度	Min. overall height	L23		179	203,5	247,5	318				
最大半径	Max. radius	R		1,5							
电机轴直径j6/k6	Motor shaft diameter j6/k6	D20		更多信息见第 163/164 页 More information on page 163/164							
输入端锁紧系统直径	Clamping system diameter input	D26									
单侧空心输出轴	Hollow output shaft on one side									F	
空心轴直径	Hollow shaft diameter	D24	H6	15	20	30	40				
总长	Total length	L1		122,5	143,5	178	217				
到轴肩的距离	Shaft length from shoulder	L4		14	16	20	25				
最小配合长度	Min. fit length	L24		20	25	30	35				
双侧空心输出轴	Hollow output shaft on both sides							G			
空心轴直径	Hollow shaft diameter	D24	H6	15	20	30	40				
轴肩	Shaft collar	D25		25	30	42	55				
总长	Total length	L1		137,5	160,5	199	243				
到轴肩的距离	Shaft length from shoulder	L4		14	16	20	25				
最小配合长度	Min. fit length	L24		20	25	30	35				

(2) 所有的尺寸单位为mm
 (3) 减速级数

(2) Dimensions in mm
 (3) Number of stages

WGN 胀紧套

WGN Shrink disc

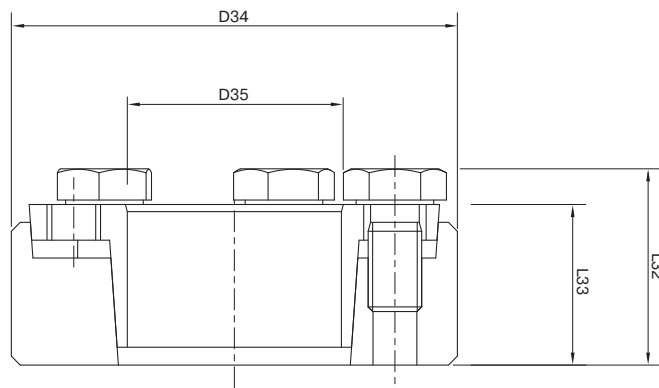

此胀紧套可以通过胀紧力锁紧的方式连接您的设备轴与WGN直角减速机中空输出轴。

This shrink disc can be used to make a force-fit connection between your machine shaft and the right angle hollow shaft gearbox WGN.

				WGN070	WGN090	WGN115	WGN142
产品编号	Art. No.			58365	58366	58367	58368
外径	Outside diameter	D34	mm	44	50	72	90
内径	Inner diameter	D35		18	24	36	50
总长 ⁽¹⁾	Overall length ⁽¹⁾	L32		19	22	27,3	31,3
夹紧长度 ⁽¹⁾	Clamp length ⁽¹⁾	L33		15	18	22	26
对边宽度	Width across flats	SW30		10	10	13	13
夹紧螺钉数量	Number of clamp screws	N30		4	5	5	8
转动惯量	Mass moment of inertia	J	kgcm ²	0,4251	0,7831	4,212	11,55

建议承载轴公差为 h6，表面粗糙度 Ra < 3,2 μm。CAD数据下载地址：www.neugart.com

For the load shaft, we recommend a tolerance of h6 and a surface roughness of Ra < 3.2 μm. CAD data can be accessed at www.neugart.com

关于胀紧套的安装步骤，请参考相应的安装说明(www.neugart.com)。

For correct installation of the shrink disc, please refer to the corresponding mounting instructions (www.neugart.com)

供货范围

1 x 胀紧套 (含螺钉)

Included parts

1 x Shrink disc (incl. screws)

⁽¹⁾ 未夹紧状态下的尺寸

⁽¹⁾ Dimensions in unclamped state



PK1 · PM1 · PM2

整合的减速机/齿轮组合：
为您的齿条应用提升价值。

齿轮是齿条驱动装置的核心元件。它将减速机的旋转运动转化为线性运动。Neugart 齿轮预先安装在减速机上，并用螺钉固定。这样，这个由减速机与齿轮构成的紧凑单元可以快速地组装在设备里，由此节省了额外的安装工作。

The integrated gearbox/pinion combination: Added value for your toothed rack applications

The pinion is the essential element of the rack and pinion drive for converting the rotatory movement of the gearbox into a linear movement. The Neugart pinion is pre-mounted on the gearbox and secured with screws. This means that the compact unit consisting of the gearbox and the pinion can be quickly installed in the application, and less installation work is required.

PK1 小齿轮
PK1 Pinion



模数
Module **1,5-5**

齿数
Number of teeth **15-27**

最大进给力
Maximum feed force **3-31 kN**

PM1 小齿轮
PM1 Pinion



模数
Module **2-4**

齿数
Number of teeth **26-45**

最大进给力
Maximum feed force **2-14 kN**

根据所选的减速机不同，可能具有以下特征：

Depending on the gearbox selected, the following features are available:

- 

E 经济型
Economy Line



增强深沟球轴承
Reinforced deep groove ball bearings
- 

P 精密型
Precision Line



输出端带有超长定心环
Extra long centering collar
- 

同轴减速机
Coaxial gearbox



圆形特大号输出法兰
Extra large round type output flange
- 

直角型减速机
Right angle gearbox



正方形输出法兰
Square type output flange
- 

直齿齿轮
Pinion with straight teeth



圆形输出法兰
Round type output flange
- 

斜齿齿轮
Pinion with helical teeth



径向轴密封
Rotary shaft seal
- 

配有预紧的圆锥滚子轴承
Preloaded tapered roller bearings



可选：降低回程间隙
Option: Reduced backlash
- 

配有预紧的角接触滚子轴承
Preloaded angular contact roller bearings

技术特点的详细解释，请从第173页读起。

Detailed explanations of the technical features starting on page 173.

PM2 小齿轮
PM2 Pinion



模数
Module **2-5**

齿数
Number of teeth **14-22**

最大进给力
Maximum feed force **6-30 kN**

斜齿齿轮

螺旋角 $\beta = -19,5283^\circ$ (左旋)
经过硬化和磨削, 精度等级 6 级

Pinion with helical teeth

Helix angle $\beta = -19,5283^\circ$ (rising to the left)
hardened and ground, Quality 6



小齿轮型号	模数	齿数	节圆直径	变位系数	进给常量	齿轮重量	最大扭矩	最大进给力	适用减速机 ⁽¹⁾⁽²⁾					
Pinion type	Module	Number of teeth	Pitch circle diameter	Profile modification factor	Feed constant	Pinion weight	Max. torque	Max. feed force	Suitable for gearbox ⁽¹⁾⁽²⁾					
	m	z	d_0	x	$d_0 \times \pi$	m_p	T_{vmax}	F_v	PSN	PLN	WPLN	PLHE	WPLHE	PLPE
	mm		mm		mm/U	kg	Nm	N						
PK1	1,5	19	30,239	0,30	95,00	0,11	68	4517	070	070	070	060	060	70
PK1	2	15	31,831	0,55	100,00	0,16	90	5650						
PK1	2	16	33,953	0,55	106,67	0,18	103	6060						
PK1	2	18	38,197	0,45	120,00	0,23	108	5540						
PK1	2	18	38,197	0,45	120,00	0,21	141	7380	090	090	090	080	080	90
PK1	2	20	42,441	0,45	133,33	0,27	183	8620						
PK1	2	22	46,686	0,45	146,67	0,33	200	8559						
PK1	2	23	48,808	0,45	153,33	0,32	229	9380						
PK1	2	25	53,052	0,45	166,67	0,39	250	9420	115	115	115	120	120	120
PK1	2	26	55,174	0,40	173,33	0,42	263	9534						
PK1	2	27	57,296	0,35	180,00	0,46	275	9590						
PK1	3	20	63,662	0,45	200,00	0,69	436	13701						
PK1	3	20	63,662	0,45	200,00	0,77	534	16770	142	142	142	-	-	155
PK1	3	22	70,028	0,45	220,00	0,94	602	17190						
PK1	3	24	76,394	0,45	240,00	1,12	660	17270						
PK1	4	20	84,883	0,40	266,67	1,64	1295	30510						

直齿齿轮

螺旋角 $\beta = 0^\circ$
经过硬化和磨削, 精度等级 6 级

Pinion with straight teeth

Helix angle $\beta = 0^\circ$
hardened and ground, Quality 6



小齿轮型号	模数	齿数	节圆直径	变位系数	进给常量	齿轮重量	最大扭矩	最大进给力	适用减速机 ⁽¹⁾⁽²⁾					
Pinion type	Module	Number of teeth	Pitch circle diameter	Profile modification factor	Feed constant	Pinion weight	Max. torque	Max. feed force	Suitable for gearbox ⁽¹⁾⁽²⁾					
	m	z	d_0	x	$d_0 \times \pi$	m_p	T_{vmax}	F_v	PSN	PLN	WPLN	PLHE	WPLHE	PLPE
	mm		mm		mm/U	kg	Nm	N						
PK1	1,5	20	30,00	0,30	94,25	0,11	43	2860	070	070	070	060	060	070
PK1	2	16	32,00	0,50	100,53	0,16	61	3810						
PK1	2	19	38,00	0,40	119,38	0,22	94	4947						
PK1	2	19	38,00	0,40	119,38	0,20	94	4940	090	090	090	080	080	090
PK1	2	22	44,00	0,30	138,23	0,28	133	6046						
PK1	3	17	51,00	0,40	160,22	0,40	225	8820	115	115	115	120	120	120
PK1	3	22	66,00	0,20	207,35	0,71	397	12030						
PK1	3	22	66,00	0,20	207,35	0,79	397	12030	142	142	142	-	-	155
PK1	3	25	75,00	0,20	235,62	1,04	525	14000						
PK1	4	19	76,00	0,30	238,76	1,32	712	18730						
PK1	4	22	88,00	0,20	276,46	1,71	986	22400	190	190	-	-	-	-
PK1	5	19	95,00	0,40	298,45	2,38	1481	31170						

⁽¹⁾ 利用 NCP 针对应用进行专门设计. 您可以查看产品页, 或者访问 www.neugart.com 网站, 进一步了解各种减速机。

⁽²⁾ 输出扭矩取决于减速机的传动比。

⁽¹⁾ Application specific configuration with NCP.

More information about the gearboxes can be found on the product pages or at www.neugart.com

⁽²⁾ The nominal output torque depends on the transmission ratio.

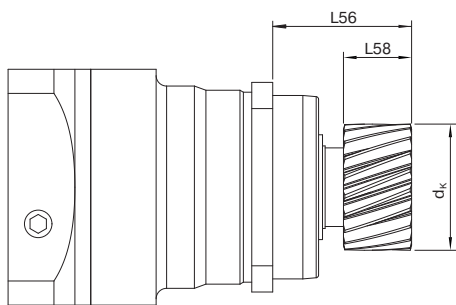

PSN/PLN 带小齿轮 (也适用于 WPLN, PLHE 和 WPLHE)
PSN/PLN with pinion (also applies to WPLN, PLHE and WPLHE)

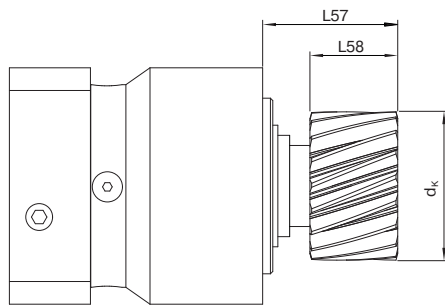

PLPE 带小齿轮
PLPE with pinion

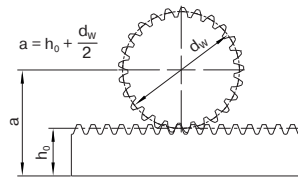

斜齿齿轮

Pinion with helical teeth

结构尺寸	小齿轮型号	模数	齿数	齿顶圆直径	齿轮节圆直径	齿轮宽度	中心距 ⁽¹⁾	输出轴的长度 (包含齿轮)	
Frame size	Pinion type	Module	Number of teeth	Tip diameter	Operating pitch circle diameter	Pinion width	Center distance ⁽¹⁾	Output shaft length with pinion	
		m	z	d_k	d_w	L58	a	L56	L57
		mm		mm	mm	mm	mm	mm	
060 / 070	PK1	1,5	19	34,06	31,14	21	33,10	51	39,1
	PK1	2	15	37,95	34,03	26	39,02	52	40,1
	PK1	2	16	40,07	36,15	26	40,08	52	40,1
	PK1	2	18	43,92	40,00	26	42,00	52	40,1
080 / 090	PK1	2	18	43,92	40,00	26	42,00	52	42,9
	PK1	2	20	48,16	44,24	26	44,12	53	42,9
	PK1	2	22	52,40	48,49	26	46,24	53	42,9
115 / 120	PK1	2	23	54,53	50,61	26	47,30	64	54
	PK1	2	25	58,74	54,85	26	49,43	64	54
	PK1	2	26	60,66	56,77	26	50,39	64	54
	PK1	2	27	62,59	58,70	26	51,35	64	54
	PK1	3	20	72,25	66,36	31	59,18	69,5	59,5
142 / 155	PK1	3	20	72,25	66,36	31	59,18	81	65,9
	PK1	3	22	76,62	72,73	31	62,36	81	65,9
	PK1	3	24	84,99	79,09	31	65,55	81	65,9
190	PK1	4	20	95,97	88,08	41	79,04	84	-

直齿齿轮

Pinion with straight teeth

结构尺寸	小齿轮型号	模数	齿数	齿顶圆直径	齿轮节圆直径	齿轮宽度	中心距 ⁽¹⁾	输出轴的长度 (包含齿轮)	
Frame size	Pinion type	Module	Number of teeth	Tip diameter	Operating pitch circle diameter	Pinion width	Center distance ⁽¹⁾	Output shaft length with pinion	
		m	z	d_k	d_w	L58	a	L56	L57
		mm		mm	mm	mm	mm	mm	
060 / 070	PK1	1,5	20	33,82	30,90	21	32,95	51	39,1
	PK1	2	16	37,92	34,00	26	39,00	52	40,1
	PK1	2	19	43,52	39,60	26	41,80	52	40,1
080 / 090	PK1	2	19	43,52	39,60	26	41,80	53	42,9
	PK1	2	22	49,12	45,20	26	44,60	53	42,9
115 / 120	PK1	3	17	59,29	53,40	31	52,70	69,5	59,5
	PK1	3	22	73,09	67,20	31	59,60	69,5	59,5
142 / 155	PK1	3	22	73,09	67,20	31	59,60	81	59,5
	PK1	3	25	82,09	76,20	31	64,12	81	65,9
	PK1	4	19	86,29	78,40	41	74,20	84	68,9
190	PK1	4	22	97,49	89,60	41	79,80	84	-
	PK1	5	19	108,89	99,00	51	83,50	84	-

⁽¹⁾ 适用于标准齿条高度 h_0 。模数 1,5 ($h_0=17,5$)，模数 2 ($h_0=22$ mm)，模数 3 ($h_0=26$ mm)，模数 4 ($h_0=35$ mm)，模数 5 ($h_0=34$ mm)。

⁽¹⁾ For standard toothed rack height h_0 . Module 1,5 ($h_0=17,5$), Module 2 ($h_0=22$ mm), Module 3 ($h_0=26$ mm), Module 4 ($h_0=35$ mm), Module 5 ($h_0=34$ mm).

PK1-PM1-PM2

斜齿齿轮

螺旋角 $\beta = -19,5283^\circ$ (左旋)
经过硬化和磨削, 精度等级 6 级

Pinion with helical teeth

Helix angle $\beta = -19,5283^\circ$ (rising to the left)
hardened and ground, Quality 6

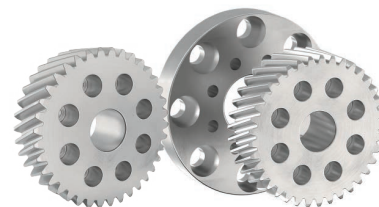

小齿轮型号	模数	齿数	转接法兰 (已包括) ^{2) 3)}	节圆直径	变位系数	进给常量	齿轮重量	最大进给力	适用减速机 ⁽¹⁾⁽²⁾				
Pinion type	Module	Number of teeth	Output flange (inclusive) ^{2) 3)}	Pitch circle diameter	Profile modification factor	Feed constant	Pinion weight	Max. feed force	Suitable for gearbox ⁽¹⁾⁽²⁾				
	m	z		d_0	x	$d_0 \times \pi$	m_p	F_v	PSFN	PLEN	WPSFN	PFHE	
	mm			mm		mm/U	kg	N					
PM1	2	26	-	55,174	0,40	173,33	0,43	2853	064	064	064	064	2)
PM1	2	27	-	57,296	0,35	180,00	0,47	2794					
PM1	2	26	064 → 090	55,174	0,40	173,33	0,60	2853	090	090	090	090	3)
PM1	2	27	064 → 090	57,296	0,35	180,00	0,64	2794					
PM1	2	35	064 → 090	74,272	0,35	233,33	1,00	2378	090	090	090	090	2)
PM1	2	37	-	78,517	0,35	246,67	0,89	4404					
PM1	2	26	064 → 110	55,174	0,40	173,33	0,76	2853	110	110	110	110	3)
PM1	2	27	064 → 110	57,296	0,35	180,00	0,79	2794					
PM1	2	35	064 → 110	74,272	0,35	233,33	1,16	2378	110	110	110	110	2)
PM1	2	40	-	84,883	0,35	266,67	0,94	7232					
PM1	2	45	-	95,493	0,30	300,00	1,25	6784	140	140	140	-	3)
PM1	2	37	090 → 140	78,517	0,35	246,67	1,54	4404					
PM1	3	31	090 → 140	98,676	0,35	310,00	2,40	3830	140	140	140	-	2)
PM1	3	35	-	111,409	0,35	350,00	2,18	13796					
PM1	3	40	-	127,324	0,35	400,00	2,92	12810	200	200	-	-	3)
PM1	4	30	-	127,324	0,20	400,00	3,67	12829					
PM1	3	35	140 → 200	111,409	0,35	350,00	4,20	13796	200	200	-	-	3)
PM1	3	40	140 → 200	127,324	0,35	400,00	4,93	12810					
PM1	4	30	140 → 200	127,324	0,20	400,00	5,68	12829					

⁽¹⁾ 利用 NCP 针对应用进行专门设计。您可以查看产品页, 或者访问 www.neugart.com 网站, 进一步了解各种减速机。

⁽²⁾ 输出扭矩取决于减速机的传动比。

⁽¹⁾ Application specific configuration with NCP.

More information about the gearboxes can be found on the product pages or at www.neugart.com

⁽²⁾ The nominal output torque depends on the transmission ratio.

2) 直接安装齿轮

2) Direct mounting of the pinion

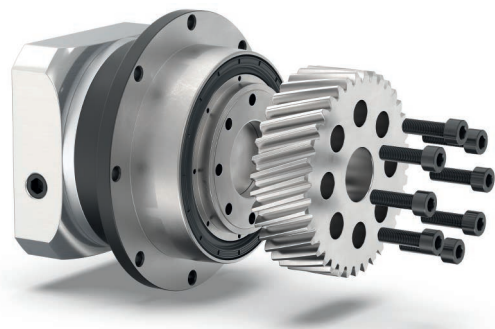

适用于 090 减速机尺寸的 PSFN090 (带有 PM1 齿轮)

PSFN090 with PM1 pinion for gearbox frame size 090

3) 转接法兰的使用 (用于安装齿轮)

3) Use of an adapter flange for installing the pinion

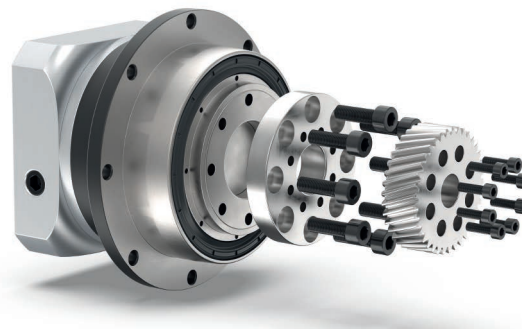

带有转接法兰的 PSFN090 (064 → 090) 与 PM1 齿轮 (适用于 064 减速机齿轮)

PSFN090 with adapter flange (064 → 090) and PM1 pinion for gearbox frame size 064

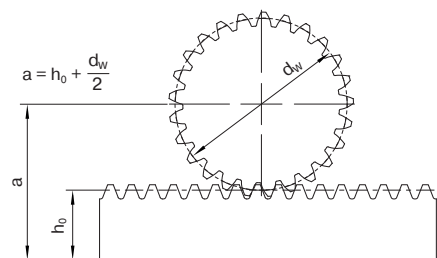
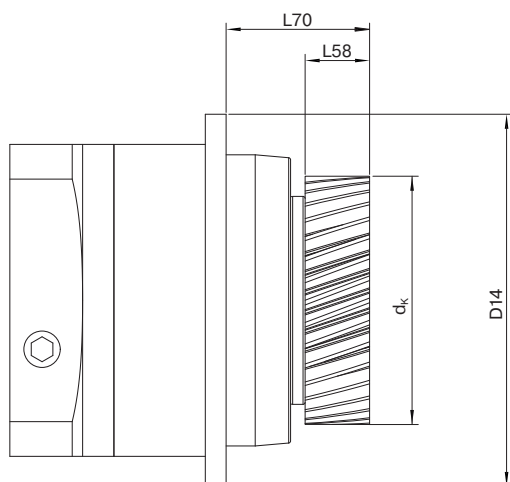

斜齿齿轮

Pinion with helical teeth

减速机尺寸	小齿轮型号	模数	齿数	转接法兰 (已包括)	齿顶圆直径	齿轮节圆直径	中心距 ⁽¹⁾	齿轮宽度	输出法兰	输出轴的 长度 (包含齿轮)
Frame size	Pinion type	Module	Number of teeth	Output flange (inclusive)	Tip diameter	Operating pitch circle diameter	Center distance ⁽¹⁾	Pinion width	Flange diameter	Output shaft length with pinion
		m	z		dk	dw	a	L58	D14	L70
		mm			mm	mm	mm	mm	mm	
064	PM1	2	26	–	60,66	56,77	50,39	26	86	45,5
	PM1	2	27	–	62,59	58,70	51,35	26	86	45,5
090	PM1	2	26	064 → 090	60,66	56,77	50,39	26	118	66
	PM1	2	27	064 → 090	62,59	58,70	51,35	26	118	66
	PM1	2	35	064 → 090	79,56	75,67	59,84	26	118	66
	PM1	2	37	–	83,81	79,92	61,96	26	118	56
110	PM1	2	26	064 → 110	60,66	56,77	50,39	26	145	65
	PM1	2	27	064 → 110	62,59	58,70	51,35	26	145	65
	PM1	2	35	064 → 110	79,56	75,67	59,84	26	145	65
	PM1	2	40	–	90,17	86,28	65,14	26	145	55
	PM1	2	45	–	100,58	96,69	70,35	26	145	55
140	PM1	2	37	090 → 140	83,81	79,92	61,96	26	179	77
	PM1	3	31	090 → 140	106,67	100,78	76,39	31	179	82
	PM1	3	35	–	119,40	113,51	82,75	31	179	69
	PM1	3	40	–	135,27	139,42	90,71	31	179	69
	PM1	4	30	–	136,77	128,92	99,46	41	179	79
200	PM1	3	35	140 → 200	119,40	113,51	82,75	31	247	100
	PM1	3	40	140 → 200	135,27	129,42	90,71	31	247	100
	PM1	4	30	140 → 200	136,77	128,92	99,46	41	247	110

⁽¹⁾ 适用于标准齿条高度 h_0 。模块 2 ($h_0 = 22$ mm), 模块 3 ($h_0 = 26$ mm), 模块 4 ($h_0 = 35$ mm).

⁽¹⁾ For standard toothed rack height h_0 . Module 2 ($h_0 = 22$ mm), Module 3 ($h_0 = 26$ mm), Module 4 ($h_0 = 35$ mm).

斜齿齿轮

螺旋角 $\beta = -19,5283^\circ$ (左旋)
 经过硬化和磨削, 精度等级 6 级

Pinion with helical teeth

Helix angle $\beta = -19,5283^\circ$ (rising to the left)
 hardened and ground, Quality 6



小齿轮型号	模数	齿数	节圆直径	变位系数	进给常量	齿轮重量	最大扭矩	最大进给力	适用减速机 ⁽¹⁾⁽²⁾			
Pinion type	Module	Number of teeth	Pitch circle diameter	Profile modification factor	Feed constant	Pinion weight	Max. torque	Max. feed force	Suitable for gearbox ⁽¹⁾⁽²⁾			
	m	z	d ₀	x	d ₀ × π	m _p	T _{vmax}	F _v	PSFN	PLFN	WPSFN	PFHE
	mm		mm		mm/U	kg	Nm	N				
PM2	2	16	33,95	0,25	106,67	0,46	124	7300	090	090	090	090
PM2	2	20	42,44	0,45	133,33	0,81	226	10650	110	110	110	110
PM2	3	14	44,56	0,20	140,00	0,89	228	10230				
PM2	2	20	42,44	0,45	133,33	1,15	231	10930	140	140	140	-
PM2	3	17	54,11	0,45	170,00	3,16	349	12930				
PM2	3	17	54,11	0,45	170,00	1,41	349	12930	200	200	-	-
PM2	4	20	84,88	0,40	266,67	4,47	1279	30140				

直齿齿轮

螺旋角 $\beta = 0^\circ$
 经过硬化和磨削, 精度等级 6 级

Pinion with straight teeth

Helix angle $\beta = 0^\circ$
 hardened and ground, Quality 6



小齿轮型号	模数	齿数	节圆直径	变位系数	进给常量	齿轮重量	最大扭矩	最大进给力	适用减速机 ⁽¹⁾⁽²⁾			
Pinion type	Module	Number of teeth	Pitch circle diameter	Profile modification factor	Feed constant	Pinion weight	Max. torque	Max. feed force	Suitable for gearbox ⁽¹⁾⁽²⁾			
	m	z	d ₀	x	d ₀ × π	m _p	T _{vmax}	F _v	PSFN	PLFN	WPSFN	PFHE
	mm		mm		mm/U	kg	Nm	N				
PM2	2	17	34,00	0,20	106,81	0,45	98	5780	090	090	090	090
PM2	2	22	44,00	0,40	138,23	0,82	194	8840	110	110	110	110
PM2	3	19	57,00	0,40	179,07	1,46	275	9650	140	140	140	-
PM2	4	22	88,00	0,20	276,46	4,54	847	19260	200	200	-	-
PM2	5	19	95,00	0,20	298,45	5,41	1304	27460				

⁽¹⁾ 利用 NCP 针对应用进行专门设计. 您可以查看产品页, 或者访问 www.neugart.com 网站, 进一步了解各种减速机。

⁽²⁾ D输出扭矩取决于减速机的传动比。

⁽¹⁾ Application specific configuration with NCP.

More information about the gearboxes can be found on the product pages or at www.neugart.com

⁽²⁾ The nominal output torque depends on the transmission ratio.

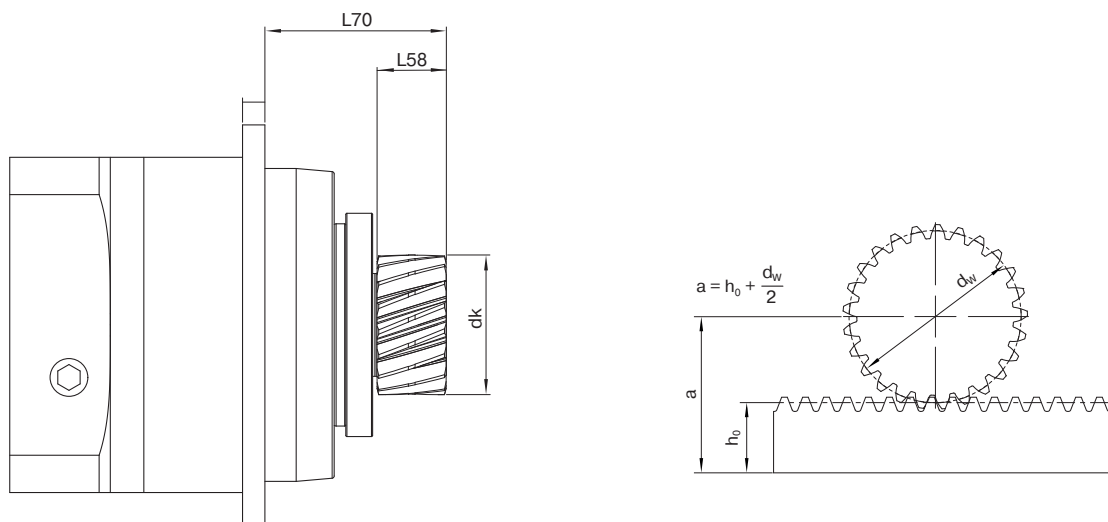

斜齿齿轮

Pinion with helical teeth

减速机尺寸	小齿轮型号	模数	齿数	齿顶圆直径	齿轮节圆直径	齿轮宽度	中心距 ⁽¹⁾	输出轴的长度 (包含齿轮)
Frame size	Pinion type	Module	Number of teeth	Tip diameter	Operating pitch circle diameter	Pinion width	Center distance ⁽¹⁾	Output shaft length with pinion
		m	z	d_k	d_w	L58	a	L70
		mm		mm	mm	mm	mm	
090	PM2	2	16	38,87	34,95	26	39,48	66,45
110	PM2	2	20	48,16	44,24	26	44,12	67,45
110	PM2	3	14	51,68	45,76	31	43,88	72,45
140	PM2	2	20	48,16	44,24	26	44,12	77,45
140	PM2	3	17	62,70	56,81	31	49,41	101,00
200	PM2	3	17	62,70	56,81	31	49,41	83,00
200	PM2	4	20	95,97	88,08	41	64,04	111,00

直齿齿轮

Pinion with straight teeth

减速机尺寸	小齿轮型号	模数	齿数	齿顶圆直径	齿轮节圆直径	齿轮宽度	中心距 ⁽¹⁾	输出轴的长度 (包含齿轮)
Frame size	Pinion type	Module	Number of teeth	Tip diameter	Operating pitch circle diameter	Pinion width	Center distance ⁽¹⁾	Output shaft length with pinion
		m	z	d_k	d_w	L58	a	L70
		mm		mm	mm	mm	mm	
090	PM2	2	17	38,72	34,80	26	39,40	66,45
110	PM2	2	22	49,52	45,60	26	44,80	67,45
140	PM2	3	19	65,29	59,40	31	50,70	83,00
200	PM2	4	22	97,49	89,60	41	64,80	111,00
200	PM2	5	19	106,89	97,00	51	67,50	121,00

⁽¹⁾ 适用于标准齿条高度 h_0 。模块 2 ($h_0 = 22$ mm), 模块 3 ($h_0 = 26$ mm), 模块 4 ($h_0 = 35$ mm), 模块 5 ($h_0 = 34$ mm)。

⁽¹⁾ For standard toothed rack height h_0 . Module 2 ($h_0 = 22$ mm), Module 3 ($h_0 = 26$ mm), Module 4 ($h_0 = 35$ mm), Modul 5 ($h_0 = 34$ mm).

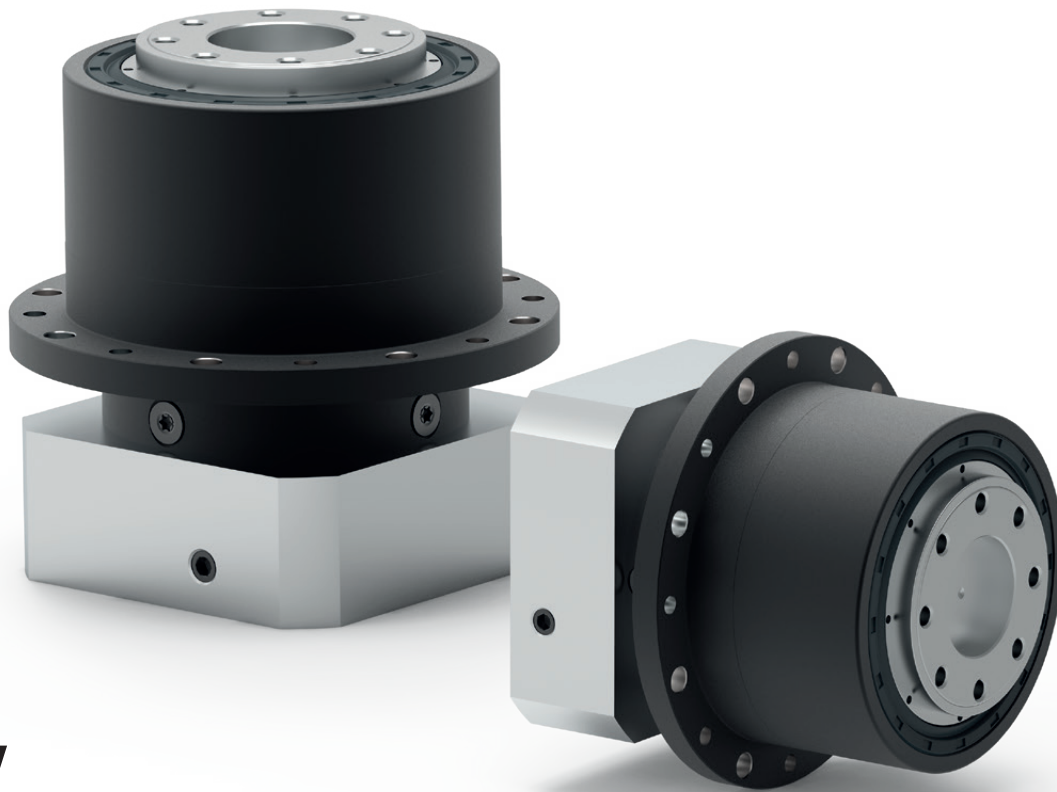

NGV

用于工业地面运输车的行星减速机。 结构紧凑，承载能力强

无人驾驶系统对驱动技术提出了特殊的要求。这些要求主要有：承受较高的径向负荷，节省空间的设计，可以全天不间断运行，且节约能源。我们的 **NGV** 行星减速机采用特殊的输出轴承设计理念，而且可以直接安装在车辆底盘上，因此能够精确地满足这些要求。

The planetary gearbox for industrial fork lift trucks. Compact and extremely resilient.

Automated guided vehicles have special requirements when it comes to drive technology. These include high radial loads, space-saving design, 24/7 use and energy efficiency. With its special output bearing concept and the option of direct mounting to the vehicle chassis, our **NGV** planetary gearbox precisely meets these requirements.

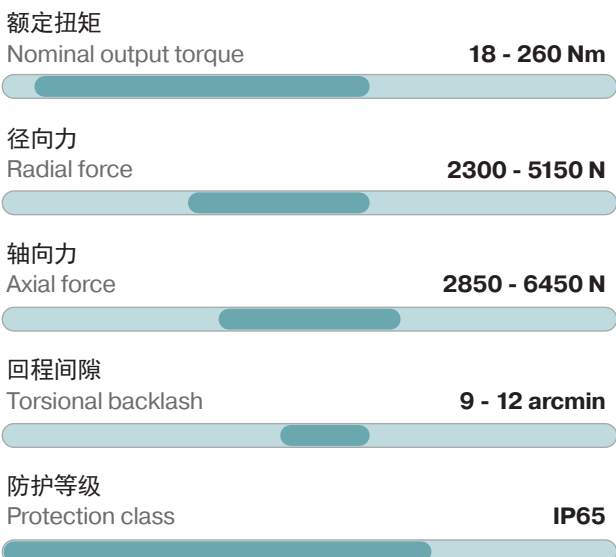

动态载荷视减速机型号而定
Dynamic load capacity per gearbox

最大动态载荷	Max. dynamic load capacity	kg
减速机包括配轮 NGV064 Ø 160 mm	NGV064 incl. wheel Ø 160 mm	350
减速机包括配轮 NGV090 Ø 200 mm	NGV090 incl. wheel Ø 200 mm	675
减速机包括配轮 NGV110 Ø 250 mm	NGV110 incl. wheel Ø 250 mm	1075

结构尺寸
Frame sizes



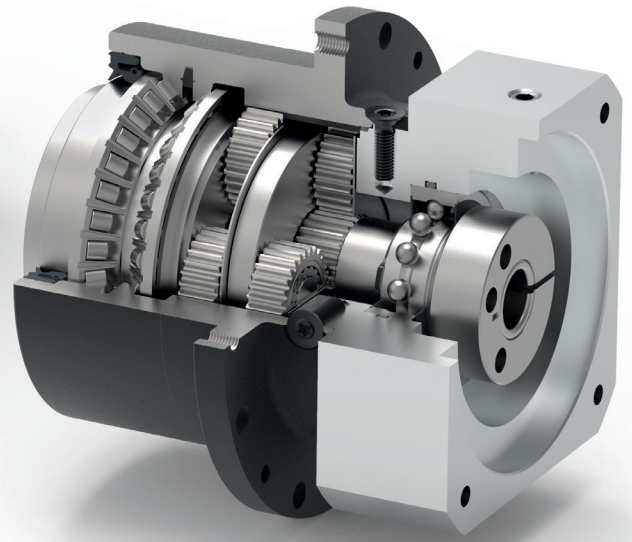
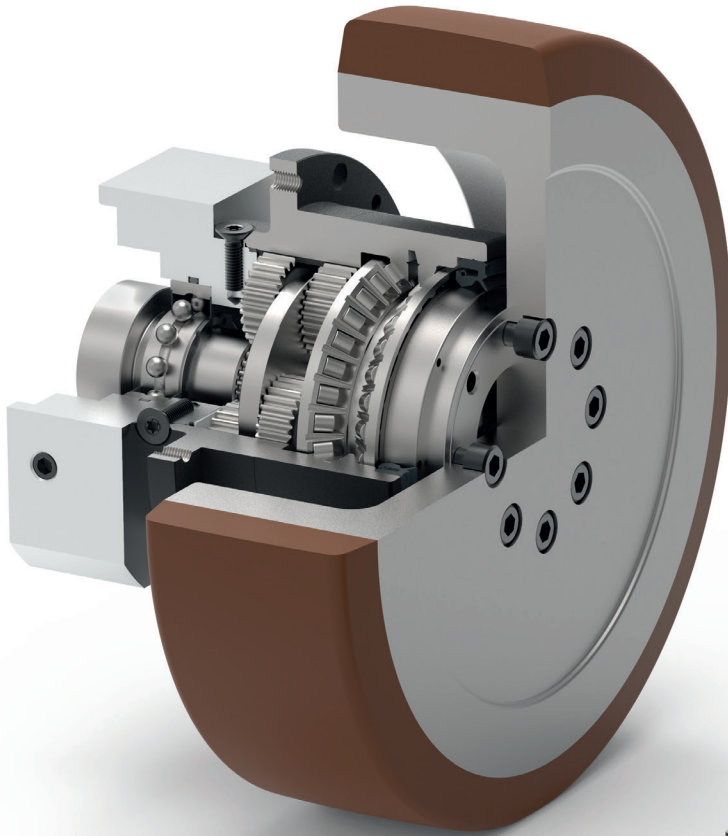

针对特定应用的减速机
Application-specific gearbox



径向轴密封
Rotary shaft seal

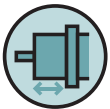

输出端带有超长定心环
Extra long centering collar



法兰输出轴 (按 ISO 9409-1 标准)
Flange output shaft (ISO 9409-1)



行星齿轮架
Planet carrier in disc design



直齿
Spur gear

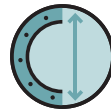

圆形特大号输出法兰
Extra large round type output flange



配有预紧的角接触滚子轴承
Preloaded angular contact roller bearings



可选：喷漆表面
——RAL 9005 黑色
Option: Painted surface
– RAL 9005 Jet black

技术特点的详细解释，请从第173页读起。
Detailed explanations of the technical features starting on page 173.

NGV:
完美的AGV减速机

NGV: The perfect gearbox for AGVs.

+ 直接安装

使用安装接口，可以把减速机直接安装在车辆上。不需要另外的适配器。

+ Direct mounting

The mounting interface allows direct mounting of the gearbox to the vehicle. No additional adapters are required.

+ 减少安装空间

减速机几乎完全被配轮包围住。因此，车辆内部所需的安装空间被降至最小。

+ Reduction of installation space

The gearbox is almost completely enclosed by the wheel. The required installation space in the vehicle is therefore reduced to a minimum.

+ 承载能力高

预胀紧的两个角接触滚子轴承可以承受较高的径向力。

+ High load capacity

The preloaded, double-designed angular contact roller bearings permit very high radial forces.

+ 不受电机限制

搭配各种不同的电机适配器，几乎可以组装在任何型号的电机上，甚至可以直接安装在电机上。

+ Motor independent

By using different motor adapters it is possible to mount almost any motor. Direct mounting of the motor is also possible.

+ 高效率，可信赖

实践证明，Neugart 经济型系列的各类减速机都具有较高的效率。它们永久润滑，因此不需要维护，在连续运行的情况下仍然极其可靠。

+ High efficiency and reliability

The proven gearbox type from the Neugart Economy series is characterized by a high efficiency. Thanks to its lifetime lubrication, it is also maintenance-free and extremely reliable, even in continuous operation.

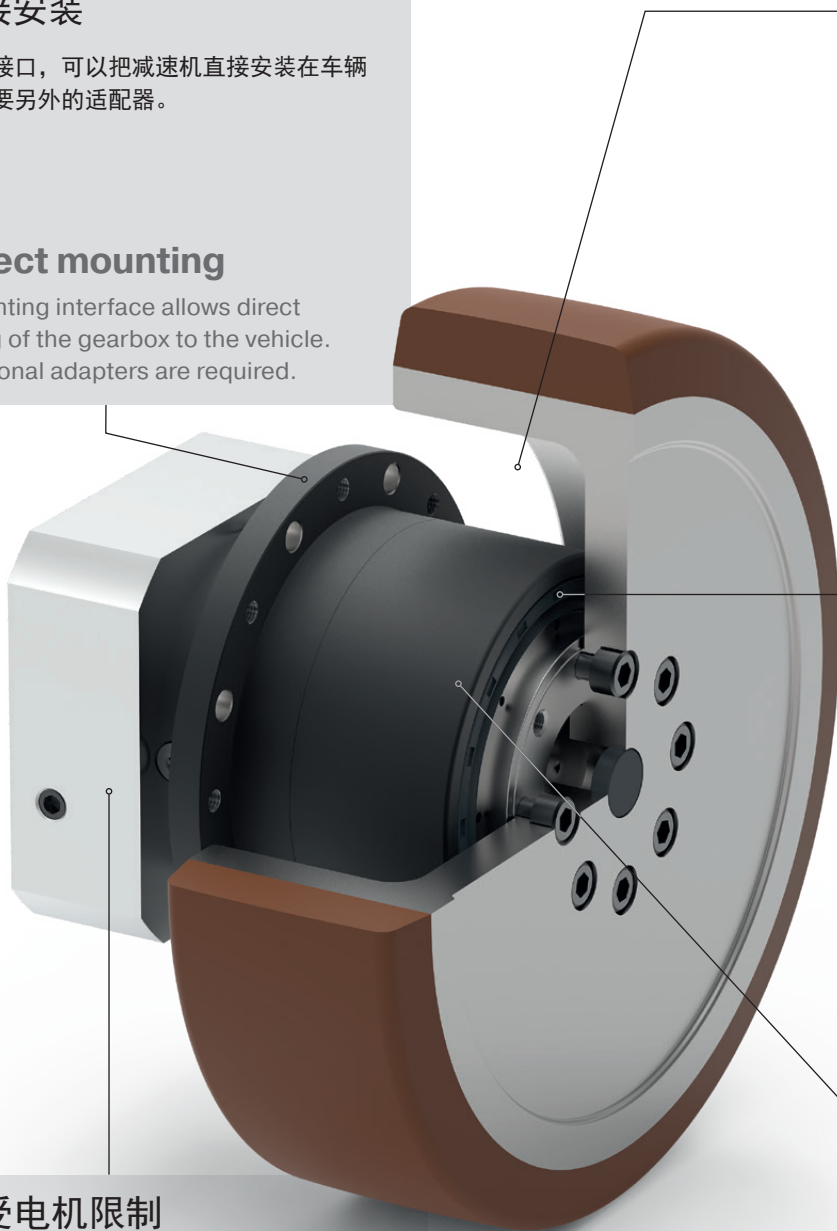

为客户专门定制的 AGV 减速机解决方案。

Neugart 具备扎实的工程与制造方面的专业知识和技能，能够为您研发与定制减速机，是您实力强劲的合作伙伴，同样适合您的车辆

Customer-specific AGV gearbox solutions.

Because of the comprehensive engineering and manufacturing know-how, Neugart is your competent partner for the development and manufacture of customized gearboxes. Also for your vehicle.

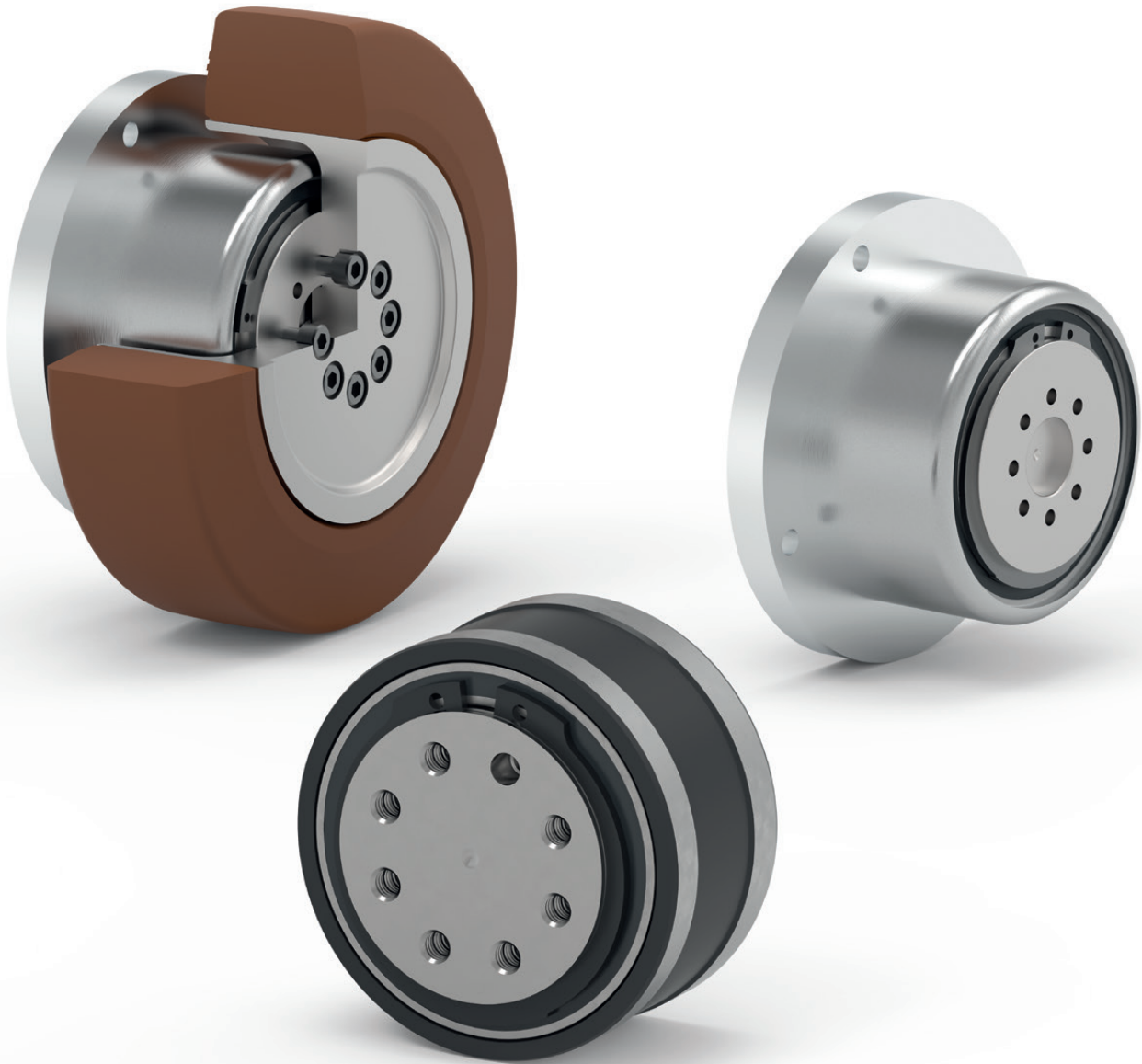

定制减速机研发实例。

Example of custom gearbox developments.

NGV 带带配轮的减速机 NGV gearbox incl. wheel

性能(减速机包括配轮)	Characteristics (gearbox incl. wheel)			NGV064	NGV090	NGV110
最大动态载荷 ⁽¹⁾	Maximum dynamic load capacity ⁽¹⁾		kg	350	675	1075
最大速度	Max. speed	v	m/s	2		
定位精度	Positioning precision		mm	0,3	0,4	0,4
总重量	Total weight		kg	3,9	7,7	16,4

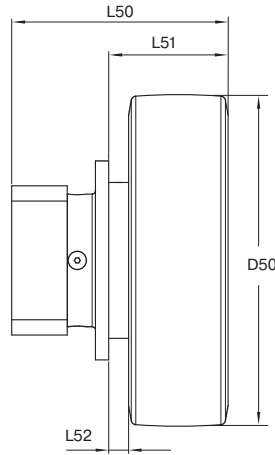

几何尺寸	Geometry			NGV064	NGV090	NGV110
配轮直径	Wheel diameter	D50	mm	160	200	250
最小总长	Min. total length	L50		98,5	130,5	158,0
法兰到配轮外边缘的距离	Distance between flange and outer edge	L51		58,0	72,0	94,0
法兰到配轮内边缘的距离	Distance between flange and inner edge	L52		8,0	12,0	14,0

NGV 减速机 NGV gearbox

Code	减速机参数	Gearbox characteristics			NGV064	NGV090	NGV110
	传动比	Ratios			9; 12; 15; 16; 20; 25; 32; 40; 64		
	使用寿命 (L _{10h})	Service life (L _{10h})	t _L	h	30.000		
	满载时效率 ⁽²⁾	Efficiency at full load ⁽²⁾	η	%	≥ 95		
	最低工作温度	Min. operating temperature	T _{min}	°C	-25		
	最高工作温度	Max. operating temperature	T _{max}		90		
	防护等级	Protection class			IP65 (从动轮上) / IP65 (at the output side)		
S	防护等级	Standard lubrication			润滑脂(终生润滑) / Grease (lifetime lubrication)		
F	食品级润滑	Food grade lubrication			润滑脂(终生润滑) / Grease (lifetime lubrication)		
L	低温润滑 ⁽³⁾	Low temperature lubrication ⁽³⁾			润滑脂(终生润滑) / Grease (lifetime lubrication)		
	安装位置	Installation position			任意 / Any		
S	标准回程间隙	Standard backlash	j _t	arcmin	≤ 12	≤ 9	≤ 9
	抗扭刚度 ⁽²⁾	Torsional stiffness ⁽²⁾	c _q	Nm / arcmin	7,3 - 11,5	19,5 - 38,5	52,0 - 95,0
	减速机重量 ⁽²⁾	Gearbox weight ⁽²⁾	m _G	kg	1,6 - 1,7	3,9 - 4,0	8,5 - 8,9
S	标准的箱体表面	Standard surface			箱体: 钢 - 热处理后氧化(黑色) Housing: Steel - heat-treated and post-oxidized (black)		
B	喷漆表面	Painted surface			RAL 9005 黑色 RAL 9005 Jet black		
	运行噪音 ⁽⁴⁾	Running noise ⁽⁴⁾	Q _g	dB(A)	60	62	65
	基于减速机输入法兰的最大弯矩 ⁽⁵⁾	Max. bending moment based on the gearbox input flange ⁽⁵⁾	M _b	Nm	12	16	40

⁽¹⁾ 带有配轮的 NGV 减速机的最大载荷。载荷为动态载荷，采用额定转矩 T_{2N}。必须使用 NCP。针对特定的应用进行设计。Fa=0
⁽²⁾ 传动比相关的数值可在 Tec Data Finder 中检索 www.neugart.com
⁽³⁾ T_{min} = -40°C。理想运行温度最高为 50°C
⁽⁴⁾ 距离减速机1 m 时；在输入转速为 n₁=3000 min⁻¹ 且无负荷时测得；i=25
⁽⁵⁾ M最大电机重量* (单位: kg) = 0.2 x M_b / 电机长度 (单位: m)
 * 电机重量对称分布
 * 水平和固定的安装位置

⁽¹⁾ Max. load capacity of NGV gearbox with NGV wheel and dynamic load with nominal torque (T_{2N}). Application-specific design with NCP required. With Fa=0
⁽²⁾ The ratio-dependent values can be retrieved in Tec Data Finder – www.neugart.com
⁽³⁾ T_{min} = -40°C. Optimal operating temperature max. 50°C
⁽⁴⁾ Sound pressure level from 1 m, measured on input running at n₁=3000 rpm no load; i=25
⁽⁵⁾ Max. motor weight* in kg = 0.2 x M_b / motor length in m
 * with symmetrically distributed motor weight
 * with horizontal and stationary mounting

NGV 减速机 NGV gearbox

输出扭矩	Output torques			NGV064	NGV090	NGV110	i ⁽¹⁾
额定输出扭矩 ⁽²⁾	Nominal output torque ⁽²⁾	T _{2N}	Nm	44	130	210	9
				44	120	260	12
				44	110	230	15
				44	120	260	16
				44	120	260	20
				40	110	230	25
				44	120	260	32
				40	110	230	40
				18	50	120	64
最大输出扭矩 ⁽²⁾	Max. output torque ⁽²⁾	T _{2max}	Nm	70	208	384	9
				70	192	416	12
				70	176	368	15
				70	192	416	16
				70	192	416	20
				64	176	368	25
				70	192	416	32
				64	176	368	40
				29	80	192	64

输出扭矩	Output torques			NGV064	NGV090	NGV110
急停扭矩 ⁽³⁾⁽⁴⁾	Emergency stop torque ⁽³⁾⁽⁴⁾	T _{2Stop}	Nm	80 - 88	190 - 260	380 - 500

输入转速	Input speeds			NGV064	NGV090	NGV110
T _{2N} 和 S1 时的平均热输入转速 ⁽²⁾	Average thermal input speed at T _{2N} and S1 ⁽²⁾	n _{1N}	min ⁻¹	4500	4000	3300 - 3500
最高机械输入转速 ⁽²⁾	Max. mechanical input speed ⁽²⁾	n _{1Limit}		7500	7000	6500

输出轴载荷	Output shaft loads			NGV064	NGV090	NGV110
20,000 h 径向力 ⁽⁵⁾⁽⁶⁾	Radial force for 20,000 h ⁽⁵⁾⁽⁶⁾	F _{r 20,000 h}	N	2300	4100	5150
20,000 h 轴向力 ⁽⁵⁾⁽⁶⁾	Axial force for 20,000 h ⁽⁵⁾⁽⁶⁾	F _{a 20,000 h}		2850	5450	6450
30,000 h 径向力 ⁽⁵⁾⁽⁶⁾	Radial force for 30,000 h ⁽⁵⁾⁽⁶⁾	F _{r 30,000 h}		2000	3650	4550
30,000 h 轴向力 ⁽⁵⁾⁽⁶⁾	Axial force for 30,000 h ⁽⁵⁾⁽⁶⁾	F _{a 30,000 h}		2500	4800	5600
最大径向力 ⁽⁶⁾⁽⁷⁾	Maximum radial force ⁽⁶⁾⁽⁷⁾	F _{r Stat}		2700	4950	7200
最大轴向力 ⁽⁶⁾⁽⁷⁾	Maximum axial force ⁽⁶⁾⁽⁷⁾	F _{a Stat}		2850	5450	6450
20,000 h 倾斜力矩 ⁽⁵⁾⁽⁷⁾	Tilting moment for 20,000 h ⁽⁵⁾⁽⁷⁾	M _{K 20,000 h}	Nm	110	278	407
30,000 h 倾斜力矩 ⁽⁵⁾⁽⁷⁾	Tilting moment for 30,000 h ⁽⁵⁾⁽⁷⁾	M _{K 30,000 h}		96	248	360

转动惯量	Moment of inertia			NGV064	NGV090	NGV110
转动惯量 ⁽³⁾	Mass moment of inertia ⁽³⁾	J	kgcm ²	0,066 - 0,132	0,367 - 0,667	1,416 - 2,432

(1) 传动比 (i=n₁/n₂)
 (2) 利用 NCP 针对应用设计转速 – www.neugart.com
 (3) 传动比相关的数值可在 Tec Data Finder 中检索 – www.neugart.com
 (4) 允许 1000 次
 (5) 数据以 n₂=100 min⁻¹ 的输出轴转速为准。
 (6) 基于输出轴末端
 (7) 更改 T_{2N}, F_r, F_a 以及周期和轴承使用寿命时, 数值存在偏差 (部分较高)。利用 NCP 针对应用进行专门设计 – www.neugart.com

(1) Ratios (i=n₁/n₂)
 (2) Ratio-dependent. Application-specific speed configurations with NCP – www.neugart.com
 (3) The ratio-dependent values can be retrieved in Tec Data Finder – www.neugart.com
 (4) Permitted 1000 times
 (5) These values are based on an output shaft speed of n₂=100 rpm
 (6) Based on the end of the output shaft
 (7) Other (sometimes higher) values following changes to T_{2N}, F_r, F_a, cycle, and service life of bearing. Application specific configuration with NCP – www.neugart.com

NGV 减速机 NGV gearbox

NGV064
NGV090

NGV110

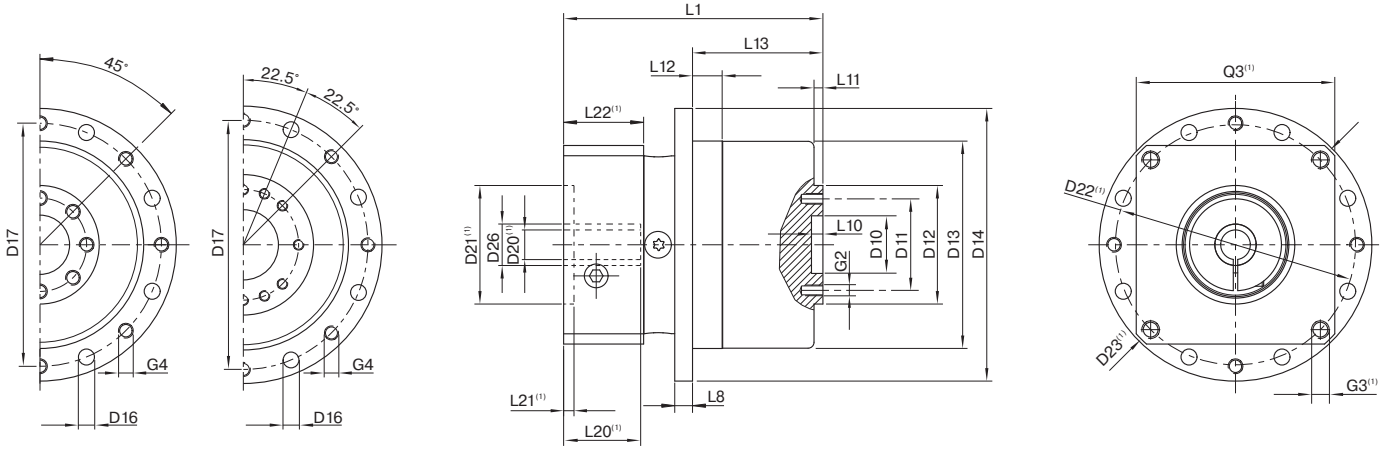

图示为带平键的 NGV090 / 2 级 / 法兰输出轴 / 19 mm 锁紧系统 / 适配电机法兰 - 单一法兰 / B5 电机法兰类型
Drawing corresponds to a NGV090 / 2-stage / flange output shaft / 19 mm clamping system / motor adaptation - one part / B5 flange type motor

(1) 具体尺寸视电机/减速机法兰而定。可以在 www.neugart.com 下 Tec Data Finder 中针对每个电机适配电机特有的输入法兰几何尺寸。
(1) The dimensions vary with the motor/gearbox flange. The input flange dimensions can be retrieved for each specific motor in Tec Data Finder at www.neugart.com

几何尺寸 ⁽²⁾	Geometry ⁽²⁾			NGV064	NGV090	NGV110
输出端定位凹槽直径	Centering diameter output shaft	D10	H7	20	31,5	40
输出端安装孔节圆直径	Pitch circle diameter output shaft	D11		31.5	50	63
法兰输出轴的直径	Flange output shaft diameter	D12	h7	40	63	80
输出法兰定位凸台直径	Centering diameter output flange	D13	h9	70	94	120
输出法兰直径	Flange diameter output	D14	h9	92	120	158
输出端安装孔直径	Mounting bore output	D16		Ø 5,4 8x45°	Ø 6.6 8x45°	Ø 9 8x45°
输出法兰安装孔节圆直径	Pitch circle diameter output flange	D17		82	108	142
最小总长	Min. total length	L1		84.5	118	144
输出端法兰厚度	Flange thickness output	L8		6	8	10
输出轴定位凸台深度	Centering depth output shaft	L10		4	6	6
		L11		3	6	6,5
输出法兰定位凸台深度	Centering depth output flange	L12		10	15	21
输出法兰长度	Output flange length	L13		44	59,5	80
输入端锁紧系统直径	Clamping system diameter input	D26		11	19	24
				14	24	35
				19	-	-
电机轴直径 j6/k6	Motor shaft diameter j6/k6	D20		5 - 19	8 - 24	11 - 35
最大允许的电机轴长	Permissible motor shaft length	L20		更多信息见第 163/164 页 More information on page 163/164		
输入端定位凹槽直径	Centering diameter input	D21				
法兰输出轴 (相似的 ISO 9409-1)	Flange output shaft (similar ISO 9409-1)					
数量 x 螺纹 x 深度	Number x thread x depth	G2		8 x M5x7	8 x M6x10	12 x M6x12
数量 x 螺纹	Number x thread	G4		8 x M5	8 x M6	8 x M8

(2) 所有的尺寸单位为mm

(2) Dimensions in mm

NGV 配轮 NGV wheel

NGV 车轮 160 NGV wheel 160
 NGV 车轮 200 NGV wheel 200

NGV 车轮 250 NGV wheel 250

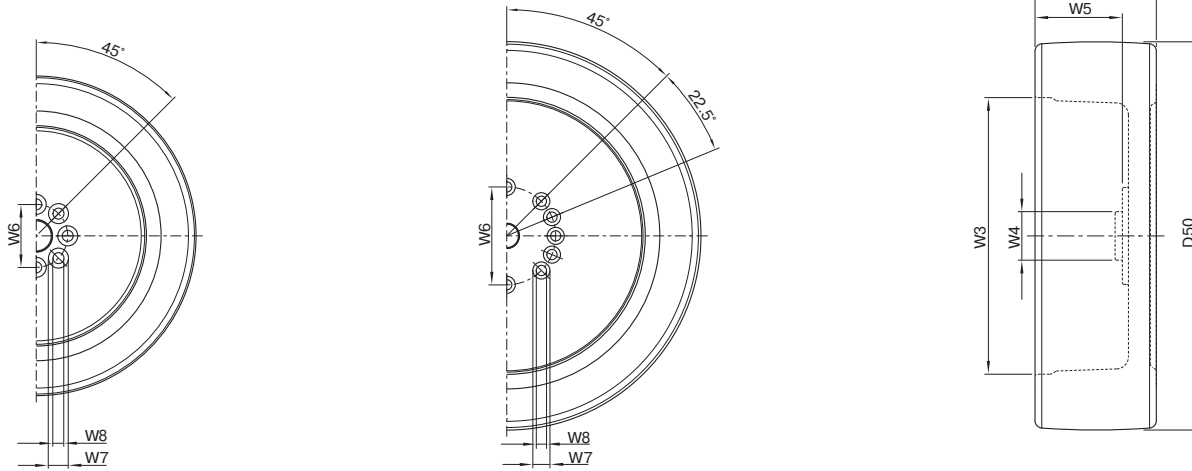

NGV 配轮的几何形状 ⁽¹⁾	Geometry NGV wheel ⁽¹⁾		NGV 车轮 160 NGV wheel 160	NGV 车轮 200 NGV wheel 200	NGV 车轮 250 NGV wheel 250
配轮的外径	Outer diameter of wheel	D50	160 ± 1,2	200 ± 1,2	250 ± 1,2
配轮的宽度	Width of wheel	W2	50 ± 0,5	60 ± 0,5	80 ± 0,5
轮缘的内径	Inner diameter of rim	W3	114	155	183
定位凸台的外径	Centering outside diameter	W4 h7	20	31,5	40
轮缘深度	Rim depth	W5	36 ± 0,2	47,5 ± 0,2	66 ± 0,2
螺纹连接配件的节距圆直径	Screw connection pitch circle diameter	W6	31,5	50	63
螺纹连接配件 (顶端) 的直径	Screw connection head diameter	W7 H13	8 x Ø 10	8 x Ø 11	12 x Ø 11
螺纹连接配件的直径	Screw connection diameter	W8 H13	8 x Ø 5,5	8 x Ø 6,6	12 x Ø 6,6

供货范围: NGV车轮含螺丝和密封盖

Scope of delivery: NGV wheel incl. screws and closure cap

NGV 配轮的特征值	Characteristics NGV wheel		NGV 车轮 160 NGV wheel 160	NGV 车轮 200 NGV wheel 200	NGV 车轮 250 NGV wheel 250
重量	Weight	kg	ca. 2,3	ca. 3,7	ca. 7,6
转动惯量	Mass inertia	J _R kgcm ²	74	203	644
滚动阻力 ⁽²⁾	Roll resistance ⁽²⁾	N	65	95	165
静摩擦系数 ⁽³⁾	Static friction coefficient ⁽³⁾	μ	> 0.25		
地面保护 (对应着配轮的接触压力)	Floor protection (corresponds to surface pressure of wheel)	N/mm ²	8,0		
温度范围	Temperature range		-30°C 至 +70°C, 短时间内可达 +90°C。 如果环境温度超过了 +40°C 承载能力将会下降。 For short periods. The load-bearing capacity is reduced at ambient temperatures higher than +40°C.		
胎面	Tread		Blickle Besthane®		
胎面颜色	Tread color		褐 / Brown		
铺砌面硬度	Tread hardness		92° Shore A		
轮体	Wheel unit		灰色铸件 / Gray cast iron		
轮体颜色	Wheel unit color		银 / Silver		
防腐蚀剂	Corrosion protection		轮体, 漆面 / Wheel unit, painted		
胎面属性 (根据胎面制造商的介绍)	Tread characteristics (according to tread manufacturer)		低噪音运行, 极低的滚动阻力, 动态承载能力较高, 地面保护, 抗磨损, 耐切割, 耐撕扯, 不落痕迹, 不着色。 Low-noise operation, extremely low rolling resistance, high dynamic loading capability, floor protecting, extremely abrasion resistant, high degree of cutting and tear resistance, traceless, contact coloration-free.		

⁽¹⁾ 所有的尺寸单位为 mm

⁽²⁾ 实验数值。速度为 4 km/h 且达到最大负载时。

⁽³⁾ 在磨光的、干燥的钢轨道上运行, 以及在光滑、干燥的混凝土上运行。

⁽¹⁾ Dimensions in mm

⁽²⁾ Empirical values. At 4 km/h and with maximum load.

⁽³⁾ On grinded, dry steel rail as well as on smooth, dry concrete.



HLAE

独一无二的行星减速机
采用经过认证的卫生设计 - 安全
清洁流程的理想之选

我们的 **HLAE** 是与众不同的：它是全世界首款已经获得认证的卫生型设计行星减速机 —— 它造型灵活，不需要径向螺钉，且性能强大，又便于清洁。它是专为敏感应用领域而研发的，例如制药、化妆品与食品领域。

The unique planetary gearbox
with certified hygienic design -
ideal for reliable cleaning processes

Our **HLAE** is unique: It is the world's first planetary gearbox in a certified hygienic design - flexible without a radial bolt, powerful and yet easy and quick to clean. It was developed specifically for applications in sensitive areas such as pharmaceuticals, cosmetics and food.

额定扭矩
Nominal output torque **15 - 171 Nm**

径向力
Radial force **450 - 1450 N**

轴向力
Axial force **550 - 2500 N**

回程间隙
Torsional backlash **7 - 12 arcmin**

防护等级
Protection class **IP65**

结构尺寸
Frame sizes



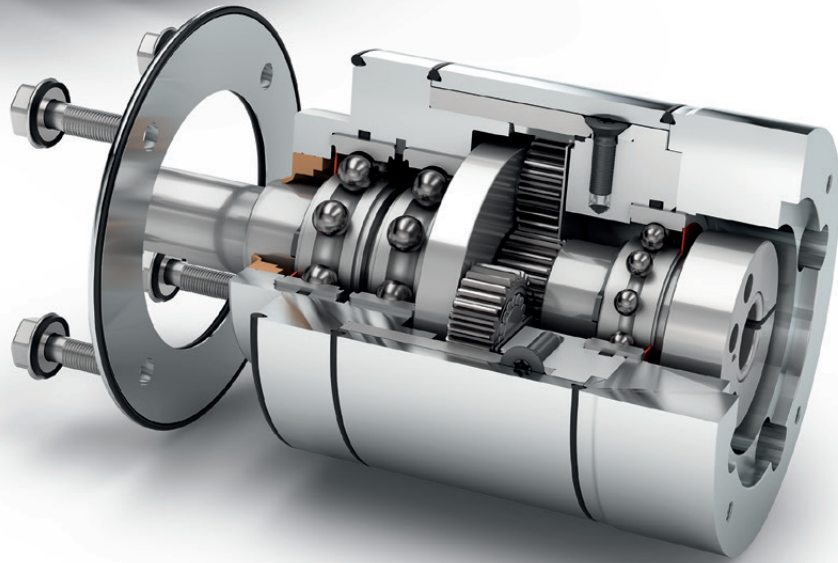
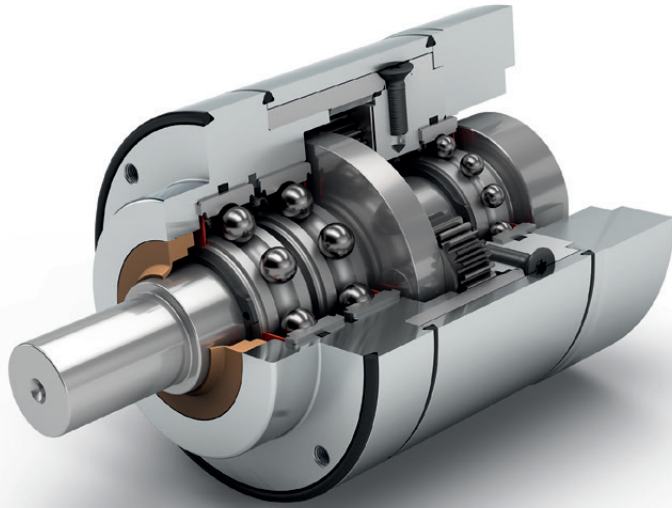

针对特定应用的减速机
Application-specific gearbox

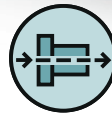

同轴减速机
Coaxial gearbox

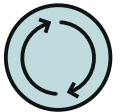

旋转方向 同方向
Equidirectional rotation



直齿
Spur gear

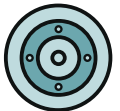

圆形输出法兰
Round type output flange



低摩擦深沟球轴承
Low-friction deep groove ball bearings



径向轴密封
Rotary shaft seal



输出端带有超长定心环
Extra long centering collar



行星齿轮架
Planet carrier in disc design



可选: FFKM 密封件
Option: FFKM seal

技术特点的详细解释, 请从第173页读起。
Detailed explanations of the technical features starting on page 173.

Code	减速机参数	Gearbox characteristics			HLAE070	HLAE090	HLAE110	p ⁽¹⁾
	使用寿命 (L _{10h})	Service life (L _{10h})	t _L	h	30.000			
	满载时效率 ⁽²⁾	Efficiency at full load ⁽²⁾	η	%	98			1
					97			2
	最低工作温度	Min. operating temperature	T _{min}	°C	-25			
	最高工作温度	Max. operating temperature	T _{max}		90			
	防护等级	Protection class		IP69K				
F	食品级润滑	Food grade lubrication		润滑脂 (终生润滑) / Grease (lifetime lubrication)				
	安装位置	Installation position		任意 / Any				
S	标准回程间隙	Standard backlash	j _t	arcmin	< 10	< 7	< 7	1
					< 12	< 9	< 9	2
	抗扭刚度 ⁽²⁾	Torsional stiffness ⁽²⁾	c _G	Nm / arcmin	2,3 - 3,1	6,6 - 8,7	14,7 - 19,5	1
					2,2 - 3,2	6,6 - 9,0	13,5 - 20,5	2
	减速机重量 ⁽²⁾	Gearbox weight ⁽²⁾	m _G	kg	2,1	3,8	7,3 - 7,4	1
					2,4 - 2,5	4,3 - 4,5	8,7 - 9,0	2
S	标准的箱体表面	Standard surface			箱体: 不锈钢 1.4404 - 电解抛光 (R _a < 0,8 μm) Housing: Stainless steel 1.4404 - electropolished (R _a < 0,8 μm)			
	运行噪音 ⁽³⁾	Running noise ⁽³⁾	Q _G	dB(A)	58	60	65	
	基于减速机输入法兰的最大弯矩 ⁽⁴⁾	Max. bending moment based on the gearbox input flange ⁽⁴⁾	M _b	Nm	8	16	40	

输出轴载荷	Output shaft loads			HLAE070	HLAE090	HLAE110	p ⁽¹⁾
20,000 h 径向力 ⁽⁵⁾⁽⁶⁾	Radial force for 20,000 h ⁽⁵⁾⁽⁶⁾	F _{r20.000 h}	N	450	900	1450	
20,000 h 轴向力 ⁽⁵⁾⁽⁶⁾	Axial force for 20,000 h ⁽⁵⁾⁽⁶⁾	F _{a20.000 h}		550	1500	2500	
30,000 h 径向力 ⁽⁵⁾⁽⁶⁾	Radial force for 30,000 h ⁽⁵⁾⁽⁶⁾	F _{r30.000 h}		400	600	1250	
30,000 h 轴向力 ⁽⁵⁾⁽⁶⁾	Axial force for 30,000 h ⁽⁵⁾⁽⁶⁾	F _{a30.000 h}		500	1000	2000	
最大径向力 ⁽⁶⁾⁽⁷⁾	Maximum radial force ⁽⁶⁾⁽⁷⁾	F _{r Stat}		1000	1250	5000	
最大轴向力 ⁽⁶⁾⁽⁷⁾	Maximum axial force ⁽⁶⁾⁽⁷⁾	F _{a Stat}		1200	1600	3800	
20,000 h 倾斜力矩 ⁽⁵⁾⁽⁷⁾	Tilting moment for 20,000 h ⁽⁵⁾⁽⁷⁾	M _{K20.000 h}	Nm	22	49	109	
30,000 h 倾斜力矩 ⁽⁵⁾⁽⁷⁾	Tilting moment for 30,000 h ⁽⁵⁾⁽⁷⁾	M _{K30.000 h}		19	33	94	

转动惯量	Moment of inertia			HLAE070	HLAE090	HLAE110	p ⁽¹⁾
转动惯量 ⁽²⁾	Mass moment of inertia ⁽²⁾	J	kgcm ²	0,065 - 0,135	0,753 - 0,866	1,579 - 2,630	1
				0,064 - 0,131	0,740 - 0,983	1,569 - 2,620	2

(1) 减速机级数
 (2) 传动比相关的数值可在 Tec Data Finder 中检索 - www.neugart.com
 (3) 距离减速机 1 m 时; 在输入转速为 n₁=3000 min⁻¹ 且无负荷时测得; i=5
 (4) 最大电机重量* (单位: kg) = 0.2 × M_b / 电机长度 (单位: m)
 * 电机重量对称分布
 * 水平和固定的安装位置
 (5) 数据以 n₂=100 min⁻¹ 的输出轴转速为准。
 (6) 以输出轴中心为准
 (7) 更改 T_{2N}, F_r, F_a 以及周期和轴承使用寿命时, 数值存在偏差 (部分较高)。利用 NCP 针对应用进行专门设计 - www.neugart.com

(1) Number of stages
 (2) The ratio-dependent values can be retrieved in Tec Data Finder - www.neugart.com
 (3) Sound pressure level from 1 m, measured on input running at n₁=3000 rpm no load; i=5
 (4) Max. motor weight* in kg = 0.2 × M_b / motor length in m
 * with symmetrically distributed motor weight
 * with horizontal and stationary mounting
 (5) These values are based on an output shaft speed of n₂=100 rpm
 (6) Based on center of output shaft
 (7) Other (sometimes higher) values following changes to T_{2N}, F_r, F_a, cycle, and service life of bearing. Application specific configuration with NCP - www.neugart.com

输出扭矩	Output torques			HLAE070	HLAE090	HLAE110	$i^{(1)}$	$p^{(2)}$
额定输出扭矩 ⁽³⁾⁽⁴⁾	Nominal output torque ⁽³⁾⁽⁴⁾	T_{2N}	Nm	28	85	115	3	1
				33	87	155	4	
				30	82	171	5	
				25	65	135	7	
				18	50	120	8	
				15	38	95	10	
				33	87	157	9	2
				33	80	171	12	
				33	82	171	15	
				33	87	171	16	
				33	87	171	20	
				30	82	171	25	
				33	87	171	32	
				30	82	171	40	
				18	50	120	64	
				15	38	95	100	
最大输出扭矩 ⁽⁴⁾⁽⁵⁾	Max. output torque ⁽⁴⁾⁽⁵⁾	T_{2max}	Nm	45	136	184	3	1
				53	140	248	4	
				48	131	274	5	
				40	104	216	7	
				29	80	192	8	
				24	61	152	10	
				53	140	251	9	2
				53	140	274	12	
				53	131	274	15	
				53	140	274	16	
				53	140	274	20	
				48	131	274	25	
				53	140	274	32	
				48	131	274	40	
				29	80	192	64	
				24	61	152	100	

⁽¹⁾ 传动比 ($i=n_1/n_2$)

⁽²⁾ 减速机级数

⁽³⁾ 利用 NCP 针对应用进行专门设计 – www.neugart.com

⁽⁴⁾ 平键 (代码 "A")时的数值: 针对交变载荷

⁽⁵⁾ 允许输出轴转动30.000转; 参见第 166 页

⁽¹⁾ Ratios ($i=n_1/n_2$)

⁽²⁾ Number of stages

⁽³⁾ Application specific configuration with NCP – www.neugart.com

⁽⁴⁾ Values for feather key (code "A"): for repeated load

⁽⁵⁾ 30,000 rotations of the output shaft permitted; see page 167

输出扭矩	Output torques			HLAE070	HLAE090	HLAE110	$i^{(1)}$	$p^{(2)}$
急停扭矩 ⁽³⁾	Emergency stop torque ⁽³⁾	T_{2Stop}	Nm	56	170	230	3	1
				66	174	310	4	
				60	164	342	5	
				50	130	270	7	
				36	100	240	8	
				30	76	190	10	
				66	174	314	9	2
				66	174	342	12	
				66	164	342	15	
				66	174	342	16	
				66	174	342	20	
				60	164	342	25	
				66	174	342	32	
				60	164	342	40	
				36	100	240	64	
				30	76	190	100	

输入转速	Input speeds			HLAE070	HLAE090	HLAE110	$i^{(1)}$	$p^{(2)}$
T_{2N} 和 S1 时的平均热输入转速 ⁽⁴⁾⁽⁵⁾	Average thermal input speed at T_{2N} and S1 ⁽⁴⁾⁽⁵⁾	n_{1N}	min^{-1}	4000 ⁽⁶⁾	2700 ⁽⁶⁾	2000 ⁽⁶⁾	3	1
				4000 ⁽⁶⁾	3000 ⁽⁶⁾	2000 ⁽⁶⁾	4	
				4000	3400 ⁽⁶⁾	2150 ⁽⁶⁾	5	
				4000	3500 ⁽⁶⁾	2600 ⁽⁶⁾	7	
				4000	3500	2800 ⁽⁶⁾	8	
				4000	3500	3000 ⁽⁶⁾	10	
				4000	3500 ⁽⁶⁾	2400 ⁽⁶⁾	9	2
				4000	3500 ⁽⁶⁾	2450 ⁽⁶⁾	12	
				4000	3500	2550 ⁽⁶⁾	15	
				4000	3500	2650 ⁽⁶⁾	16	
				4000	3500	2850 ⁽⁶⁾	20	
				4000	3500	2950 ⁽⁶⁾	25	
				4000	3500	3000 ⁽⁶⁾	32	
				4000	3500	3000	40	
				4000	3500	3000	64	
				4000	3500	3000	100	
				最高机械输入转速 ⁽⁴⁾	Max. mechanical input speed ⁽⁴⁾	n_{1Limit}	min^{-1}	

(1) 传动比 ($i=n_1/n_2$)
 (2) 减速机级数
 (3) 允许 1000 次
 (4) 利用 NCP 针对应用设计转速 – www.neugart.com
 (5) 定义请参见第 166 页
 (6) 在 50% T_{2N} 输出和 S1 模式下的平均热输入转速

(1) Ratios ($i=n_1/n_2$)
 (2) Number of stages
 (3) Permitted 1000 times
 (4) Application-specific speed configurations with NCP – www.neugart.com
 (5) See page 167 for the definition
 (6) Average thermal input speed at 50% T_{2N} and S1

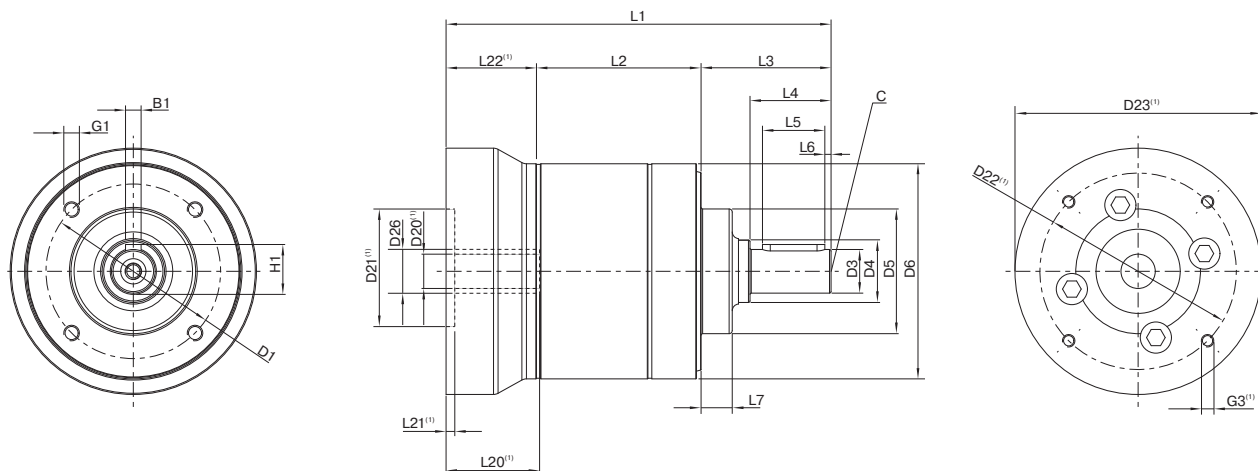

图示为带平键的 HLAE070 / 1 级 / 附带平键的输出轴 / 11 mm 锁紧系统 / 适配电机法兰 - 单一法兰 / B5 电机法兰类型
 Drawing corresponds to a HLAE070 / 1-stage / output shaft with feather key / 11 mm clamping system / motor adaptation – one part / B5 flange type motor

⁽¹⁾ 具体尺寸视电机/减速机法兰而定。可以在 www.neugart.com 下 Tec Data Finder 中针对每个电机适配电机特有的输入法兰几何尺寸。
⁽¹⁾ The dimensions vary with the motor/gearbox flange. The input flange dimensions can be retrieved for each specific motor in Tec Data Finder at www.neugart.com

几何尺寸 ⁽²⁾	Geometry ⁽²⁾			HLAE070	HLAE090	HLAE110	p ⁽³⁾	Code
输出端安装孔节圆直径	Pitch circle diameter output	D1		56	75	90		
输出轴直径	Shaft diameter output	D3	h7	14	20	25		
输出轴轴肩直径	Shaft collar output	D4		20	25	35		
输出端定位凸台直径	Centering diameter output	D5	h7	40	58	65		
箱体直径	Housing diameter	D6		69	88	109		
安装螺纹 x 深度	Mounting thread x depth	G1	4x	M5x11	M6x12	M8x20		
最小总长	Min. total length	L1		123,5	146	191	1	
				135,5	166	219	2	
箱体长度	Housing length	L2		53,0	68,0	89,0	1	
				65,0	88,0	117,0	2	
输出轴轴长	Shaft length output	L3		41,7	50	66,5		
输出端定位凸台深度	Centering depth output	L7		10	13	14		
电机轴直径j6/k6	Motor shaft diameter j6/k6	D20		更多信息见第 163/164 页 More information on page 163/164				
输入端锁紧系统直径	Clamping system diameter input	D26		更多信息见第 163/164 页 More information on page 163/164				
带平键的输出轴 (DIN 6885-1)	Output shaft with feather key (DIN 6885-1)			A 5x5x20	A 6x6x25	A 8x7x35		A
平键宽度 (DIN 6885-1)	Feather key width (DIN 6885-1)	B1		5	6	8		
含平键在内的轴高 (DIN 6885-1)	Shaft height including feather key (DIN 6885-1)	H1		16	22,5	28		
到轴肩的距离	Shaft length from shoulder	L4		26	32	45		
平键长度	Feather key length	L5		20	25	35		
到轴端的距离	Distance from shaft end	L6		2	2,5	5		
中心孔 (DIN 332 DR 形)	Center hole (DIN 332, type DR)	C		M5x12,5	M6x16	M10x22		
光滑输出轴	Smooth output shaft							B
到轴肩的距离	Shaft length from shoulder	L4		26	32	45		

⁽²⁾ 所有的尺寸单位为mm
⁽³⁾ 减速机级数

⁽²⁾ Dimensions in mm
⁽³⁾ Number of stages

HLAE 密封套件 HLAE Sealing kit

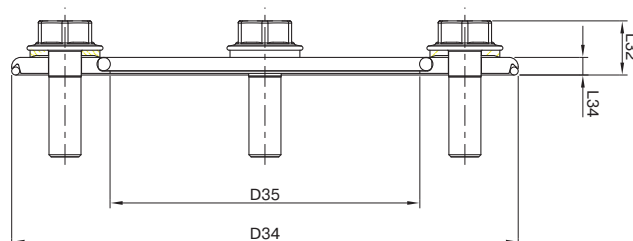

HLAE 配有可自由安装的密封套件可提供最大程度的卫生级保护，并可普遍适用于不同的设备侧面安装厚度。即为设备提供了最大程度的灵活性，同时又能满足最严格的卫生级别要求。

The freely positionable sealing kit for the HLAE provides maximum hygienic protection, making it universally suitable for different machine side thicknesses. It therefore gives you maximum flexibility for connecting to the machine while satisfying the strictest hygienic requirements.

				HLAE070	HLAE090	HLAE110
产品编号	Art. No.			63911	63858	64130
外径	Outside diameter	D34	mm	75	95	120
内径	Inner diameter	D35		40	58	65
总长	Overall length	L32		8,5	9,5	11,5
垫片长度	Disc length	L34		3	3	3
对边宽度	Width across flats	SW30		8	10	13
数量 x 螺钉 x 长度	Quantity x screw x length	G30		4 x M5x16	4 x M6x20	4 x M8x25

关于密封套件的安装步骤，请参考相应的安装说明(www.neugart.com)。 CAD数据下载地址: www.neugart.com

For correct installation of the sealing kit, please refer to the corresponding mounting instructions (www.neugart.com). CAD data can be accessed at www.neugart.com

供货范围

- 1 x 不锈钢电解抛光垫片
- 1 x EPDM 密封圈(针对设备应用的密封件)
- 1 x EPDM 密封圈(针对减速机的密封件)
- 4 x USIT-VA 包括带 EPDM 涂层的密封垫片，符合 EHEDG标准
- 4 x 卫生型设计不锈钢螺钉（电解抛光），符合 EHEDG标准

Included parts

- 1 x electropolished stainless steel disc
- 1 x EPDM sealing ring (seal to application)
- 1 x EPDM sealing ring (seal to gearbox)
- 4 x USIT-VA with EPDM coated sealing washer, EHEDG-compliant
- 4 x Hygienic Design stainless steel screw (electropolished), EHEDG-compliant

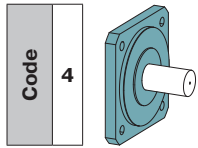

针对 PLN
For PLN

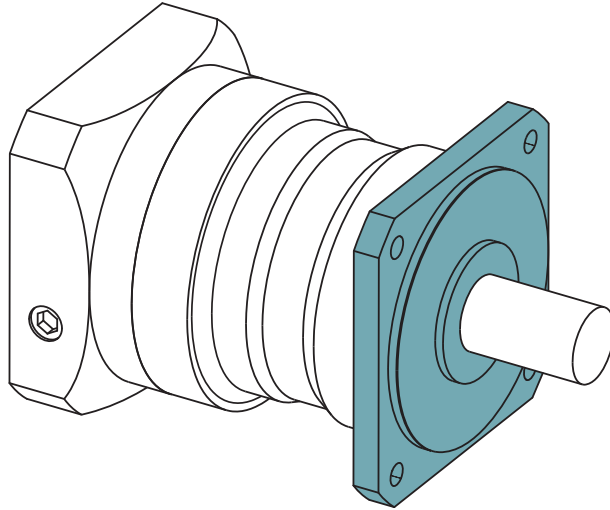

其他规格的减速机特点,输出轴负载,输出扭矩、输入转速和尺寸没有列在这里, 对应于细节在98到101页。

Other specifications for gearbox characteristics, output shaft loads, output torques, input speeds and dimensions not listed here correspond to the details on pages 98 to 101.

输出轴载荷	Output shaft loads			PLN070	PLN090	PLN115	PLN142	PLN190	p ⁽¹⁾
20,000 h 径向力 ⁽²⁾⁽³⁾	Radial force for 20,000 h ⁽²⁾⁽³⁾	$F_{r20.000h}$	N	4200	5500	6000	12500	21000	
30,000 h 径向力 ⁽²⁾⁽³⁾	Radial force for 30,000 h ⁽²⁾⁽³⁾	$F_{r30.000h}$		3700	4800	5400	11400	18000	
最大径向力 ⁽³⁾⁽⁴⁾	Maximum radial force ⁽³⁾⁽⁴⁾	F_{rStat}		4200	5500	6000	12500	21000	
20,000 h 倾斜力矩 ⁽²⁾⁽⁴⁾	Tilting moment for 20,000 h ⁽²⁾⁽⁴⁾	$M_{K20.000h}$	Nm	251	383	488	1420	2535	
30,000 h 倾斜力矩 ⁽²⁾⁽⁴⁾	Tilting moment for 30,000 h ⁽²⁾⁽⁴⁾	$M_{K30.000h}$		221	335	439	1295	2173	

输入转速	Input speeds			PLN070	PLN090	PLN115	PLN142	PLN190	i ⁽⁵⁾	p ⁽¹⁾
T _{2N} 和 S1 时的平均热输入转速 ⁽⁶⁾⁽⁷⁾	Average thermal input speed at T _{2N} and S1 ⁽⁶⁾⁽⁷⁾	n _{1N}	min ⁻¹	1850 ⁽⁸⁾	1800 ⁽⁸⁾	1400 ⁽⁸⁾	800 ⁽⁸⁾	650 ⁽⁸⁾	3	1
				2150 ⁽⁸⁾	1950 ⁽⁸⁾	1450 ⁽⁸⁾	850 ⁽⁸⁾	700 ⁽⁸⁾	4	
				2450 ⁽⁸⁾	2350 ⁽⁸⁾	1850 ⁽⁸⁾	950 ⁽⁸⁾	750 ⁽⁸⁾	5	
				3200 ⁽⁸⁾	3300 ⁽⁸⁾	2600 ⁽⁸⁾	1400 ⁽⁸⁾	1100 ⁽⁸⁾	7	
				3500 ⁽⁸⁾	3700 ⁽⁸⁾	2950 ⁽⁸⁾	1650 ⁽⁸⁾	1350 ⁽⁸⁾	8	
				4050 ⁽⁸⁾	4000 ⁽⁸⁾	3500 ⁽⁸⁾	2100 ⁽⁸⁾	1750 ⁽⁸⁾	10	
				3300 ⁽⁸⁾	3150 ⁽⁸⁾	2300 ⁽⁸⁾	1200 ⁽⁸⁾	950 ⁽⁸⁾	12	
				3700 ⁽⁸⁾	3750 ⁽⁸⁾	2750 ⁽⁸⁾	1450 ⁽⁸⁾	1150 ⁽⁸⁾	15	
				3500 ⁽⁸⁾	3300 ⁽⁸⁾	2400 ⁽⁸⁾	1200 ⁽⁸⁾	1000 ⁽⁸⁾	16	
				4000 ⁽⁸⁾	3900 ⁽⁸⁾	2850 ⁽⁸⁾	1500 ⁽⁸⁾	1200 ⁽⁸⁾	20	
				4350 ⁽⁸⁾	4000 ⁽⁸⁾	3150 ⁽⁸⁾	1700 ⁽⁸⁾	1300 ⁽⁸⁾	25	
				4500 ⁽⁸⁾	4000	3500 ⁽⁸⁾	2100 ⁽⁸⁾	1750 ⁽⁸⁾	32	
				4500	4000	3500	2350 ⁽⁸⁾	1900 ⁽⁸⁾	40	
				4500	4000	3500	2950 ⁽⁸⁾	2400 ⁽⁸⁾	64	
				4500	4000	3500	3000	2500	100	

⁽¹⁾ 减速机级数

⁽²⁾ 数据以 n₂=100 min⁻¹ 的输出轴转速为准。

⁽³⁾ 以输出轴中心为准

⁽⁴⁾ 更改 T_{2N}, F_r, F_a 以及周期和轴承使用寿命时, 数值存在偏差(部分较高)。利用 NCP 针对应用进行专门设计 - www.neugart.com

⁽⁵⁾ 传动比 (i=n₁/n₂)

⁽⁶⁾ 利用 NCP 针对应用设计转速 - www.neugart.com

⁽⁷⁾ 定义请参见第 166 页

⁽⁸⁾ 在 50% T_{2N} 输出和 S1 模式下的平均热输入转速

⁽¹⁾ Number of stages

⁽²⁾ These values are based on an output shaft speed of n₂=100 rpm

⁽³⁾ Based on center of output shaft

⁽⁴⁾ Other (sometimes higher) values following changes to T_{2N}, F_r, F_a, cycle, and service life of bearing. Application specific configuration with NCP - www.neugart.com

⁽⁵⁾ Ratios (i=n₁/n₂)

⁽⁶⁾ Application-specific speed configurations with NCP - www.neugart.com

⁽⁷⁾ See page 167 for the definition

⁽⁸⁾ Average thermal input speed at 50% T_{2N} and S1

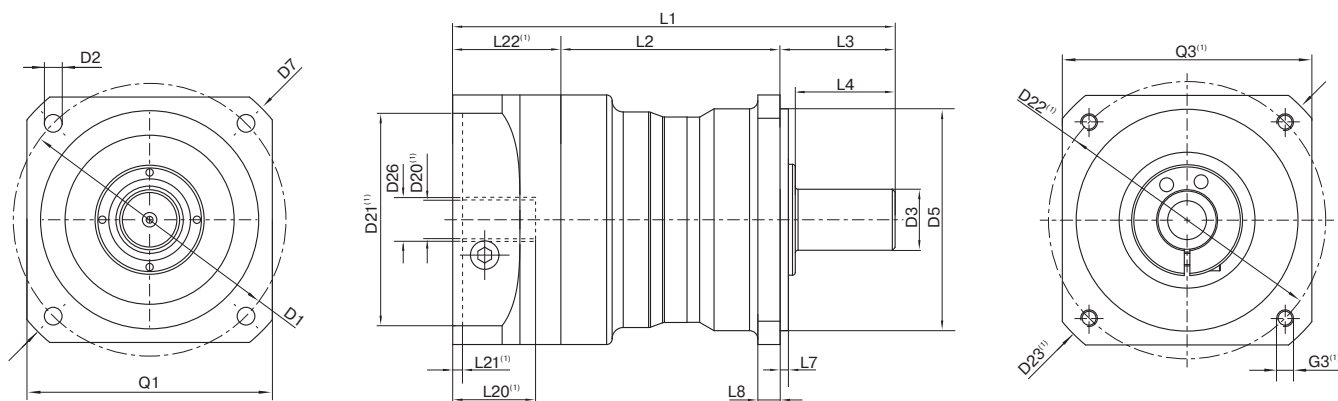

图示为带平键的 PLE060 / 1 级 / 附带平键的输出轴 / 11 mm 锁紧系统 / 适配电机法兰 - 单一法兰 / B5 电机法兰类型
 Drawing corresponds to a PLN090 / 1-stage / smooth output shaft / output flange PLS-compatible / 19 mm clamping system / motor adaptation - 2-part - round universal flange / B5 flange type motor

⁽¹⁾ 具体尺寸视电机/减速机法兰而定。可以在 www.neugart.com 下 Tec Data Finder 中针对每个电机适配电机特有的输入法兰几何尺寸。

⁽¹⁾ The dimensions vary with the motor/gearbox flange. The input flange dimensions can be retrieved for each specific motor in Tec Data Finder at www.neugart.com

几何尺寸 ⁽²⁾	Geometry ⁽²⁾			PLN070	PLN090	PLN115	PLN142	PLN190	p ⁽³⁾	Code
输出端安装孔节圆直径	Pitch circle diameter output	D1		75	100	130	165	215		
输出端安装孔直径	Mounting bore output	D2	4x	5,5	6,5	8,5	11,0	13,5		
输出轴直径	Shaft diameter output	D3	k6	19	22	32	40	55		
输出端定位凸台直径	Centering diameter output	D5	h7	60	80	110	130	160		
输出法兰对角线尺寸	Diagonal dimension output	D7		92	116	145	185	240		
输出端法兰外方	Flange cross section output	Q1	■	70	90	115	142	190		
最小总长	Min. total length	L1		137,5	159,5	201	276	310,5	1	
				166,5	191,5	241	335	382,5	2	
箱体长度	Housing length	L2		74,5	79	84,5	114,5	138	1	
				104	111	125	173,5	210	2	
输出轴轴长	Shaft length output	L3		32	41,5	64,5	87	90		
输出端定位凸台深度	Centering depth output	L7		3	3	4,5	5	6		
输出端法兰厚度	Flange thickness output	L8		7	8	10	20	20		
电机轴直径j6/k6	Motor shaft diameter j6/k6	D20		更多信息见第 163/164 页 More information on page 163/164						
输入端锁紧系统直径	Clamping system diameter input	D26								
带平键的输出轴 (DIN 6885-1)	Output shaft with feather key (DIN 6885-1)			A 6x6x20	A 6x6x28	A 10x8x50	A 12x8x65	A 16x10x70		A
平键宽度 (DIN 6885-1)	Feather key width (DIN 6885-1)	B1		6	6	10	12	16		
含平键在内的轴高 (DIN 6885-1)	Shaft height including feather key (DIN 6885-1)	H1		21,5	24,5	35	43	59		
到轴肩的距离	Shaft length from shoulder	L4		28	36	58	80	82		
平键长度	Feather key length	L5		20	28	50	65	70		
到轴端的距离	Distance from shaft end	L6		4	4	4	8	6		
中心孔 (DIN 332 DR 形)	Center hole (DIN 332, type DR)	C		M6x16	M8x19	M12x28	M16x36	M20x42		
光滑输出轴	Smooth output shaft									
到轴肩的距离	Shaft length from shoulder	L4		28	36	58	80	82		

⁽²⁾ 所有的尺寸单位为mm

⁽³⁾ 减速机级数

⁽²⁾ Dimensions in mm

⁽³⁾ Number of stages

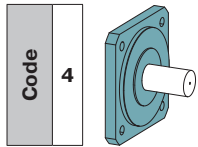

针对 WPLN
For WPLN

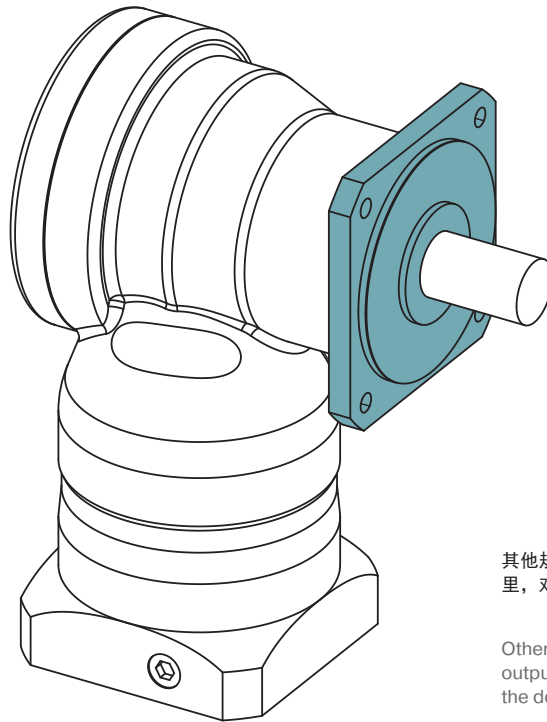

其他规格的减速机特点,输出轴负载,输出扭矩、输入转速和尺寸没有列在这里, 对应于细节在116到119页。

Other specifications for gearbox characteristics, output shaft loads, output torques, input speeds and dimensions not listed here correspond to the details on pages 116 to 119.

输出轴载荷	Output shaft loads			WPLN070	WPLN090	WPLN115	WPLN142	p ⁽¹⁾	
20,000 h 径向力 ⁽²⁾⁽³⁾	Radial force for 20,000 h ⁽²⁾⁽³⁾	$F_{r20,000h}$	N	4000	5200	6000	12500	1	
				4200	5500	6000	12500	2	
30,000 h 径向力 ⁽²⁾⁽³⁾	Radial force for 30,000 h ⁽²⁾⁽³⁾	$F_{r30,000h}$		3500	4800	6000	10900	1	
				3700	4800	5400	11400	2	
最大径向力 ⁽³⁾⁽⁴⁾	Maximum radial force ⁽³⁾⁽⁴⁾	F_{rStat}		4000	5200	6000	12500	1	
				4200	5500	6000	12500	2	
20,000 h 倾斜力矩 ⁽²⁾⁽⁴⁾	Tilting moment for 20,000 h ⁽²⁾⁽⁴⁾	$M_{K20,000h}$		Nm	402	624	1010	2225	1
					422	660	1010	2225	2
30,000 h 倾斜力矩 ⁽²⁾⁽⁴⁾	Tilting moment for 30,000 h ⁽²⁾⁽⁴⁾	$M_{K30,000h}$	352		576	1010	1940	1	
			372		576	909	2029	2	

输入转速	Input speeds			WPLN070	WPLN090	WPLN115	WPLN142	i ⁽⁵⁾	p ⁽¹⁾
T _{2N} 和 S1 时的平均热输入转速 ⁽⁶⁾⁽⁷⁾	Average thermal input speed at T _{2N} and S1 ⁽⁶⁾⁽⁷⁾	n_{1N}	min ⁻¹	1700 ⁽⁸⁾	1550 ⁽⁸⁾	1050 ⁽⁸⁾	900 ⁽⁸⁾	4	1
				1850 ⁽⁸⁾	1750 ⁽⁸⁾	1150 ⁽⁸⁾	950 ⁽⁸⁾	5	
				2150 ⁽⁸⁾	2100 ⁽⁸⁾	1300 ⁽⁸⁾	1150 ⁽⁸⁾	7	
				2200 ⁽⁸⁾	2100 ⁽⁸⁾	1350 ⁽⁸⁾	1150 ⁽⁸⁾	8	
				2300 ⁽⁸⁾	2200 ⁽⁸⁾	1400 ⁽⁸⁾	1200 ⁽⁸⁾	10	
				1700 ⁽⁸⁾	1650 ⁽⁸⁾	1550 ⁽⁸⁾	900 ⁽⁸⁾	16	
				1850 ⁽⁸⁾	1900 ⁽⁸⁾	1800 ⁽⁸⁾	950 ⁽⁸⁾	20	2
				2000 ⁽⁸⁾	2100 ⁽⁸⁾	2000 ⁽⁸⁾	1050 ⁽⁸⁾	25	
				2000 ⁽⁸⁾	2050 ⁽⁸⁾	2000 ⁽⁸⁾	1300 ⁽⁸⁾	28	
				2100 ⁽⁸⁾	2100 ⁽⁸⁾	2050 ⁽⁸⁾	1350 ⁽⁸⁾	32	
				2200 ⁽⁸⁾	2150 ⁽⁸⁾	2050 ⁽⁸⁾	1350 ⁽⁸⁾	35	
				2200 ⁽⁸⁾	2150 ⁽⁸⁾	2050 ⁽⁸⁾	1350 ⁽⁸⁾	40	
				2300 ⁽⁸⁾	2300 ⁽⁸⁾	2250 ⁽⁸⁾	1450 ⁽⁸⁾	50	
				2400 ⁽⁸⁾	2750 ⁽⁸⁾	2700 ⁽⁸⁾	1650 ⁽⁸⁾	64	
				2500 ⁽⁸⁾	2900 ⁽⁸⁾	2850 ⁽⁸⁾	1800 ⁽⁸⁾	100	

(1) 减速机级数
 (2) 数据以 $n_2=100 \text{ min}^{-1}$ 的输出轴转速为准。
 (3) 以输出轴中心为准
 (4) 更改 T_{2N}, F_r, F_a 以及周期和轴承使用寿命时, 数值存在偏差(部分较高)。利用 NCP 针对应用进行专门设计 - www.neugart.com
 (5) 传动比 ($i=n_1/n_2$)
 (6) 利用 NCP 针对应用设计转速 - www.neugart.com
 (7) 定义请参见第 166 页
 (8) 在 50% T_{2N} 输出和 S1 模式下的平均热输入转速

(1) Number of stages
 (2) These values are based on an output shaft speed of $n_2=100 \text{ rpm}$
 (3) Based on center of output shaft
 (4) Other (sometimes higher) values following changes to T_{2N}, F_r, F_a, cycle, and service life of bearing. Application specific configuration with NCP - www.neugart.com
 (5) Ratios ($i=n_1/n_2$)
 (6) Application-specific speed configurations with NCP - www.neugart.com
 (7) See page 167 for the definition
 (8) Average thermal input speed at 50% T_{2N} and S1

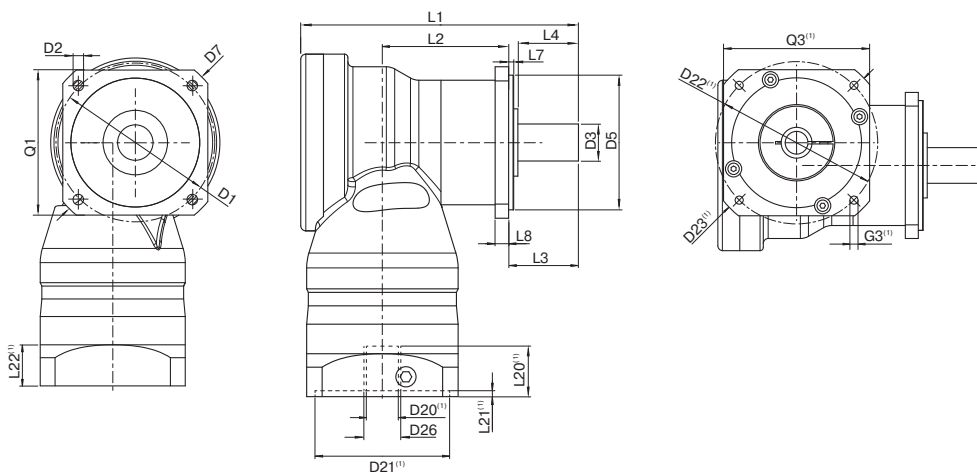

图示为带平键的 WPLN090 / 1 级 / 光滑输出轴 / 19 mm 锁紧系统 / 适配电机法兰 - 2 件式 - 圆形通用法兰 / B5 电机法兰类型
 Drawing corresponds to a WPLN090 / 1-stage / smooth output shaft / output flange WPLS-compatible / 14 mm clamping system / motor adaptation - 2-part - round universal flange / B5 flange type motor

⁽¹⁾ 具体尺寸视电机/减速机法兰而定。可以在 www.neugart.com 下 Tec Data Finder 中针对每个电机适配电机特有的输入法兰几何尺寸。
⁽¹⁾ The dimensions vary with the motor/gearbox flange. The input flange dimensions can be retrieved for each specific motor in Tec Data Finder at www.neugart.com

几何尺寸 ⁽²⁾	Geometry ⁽²⁾			WPLN070	WPLN090	WPLN115	WPLN142	p ⁽³⁾	Code
输出端安装孔节圆直径	Pitch circle diameter output	D1		75	100	130	165		
输出端安装孔直径	Mounting bore output	D2	4x	5,5	6,5	8,5	11,0		
输出轴直径	Shaft diameter output	D3	k6	19	22	32	40		
输出端定位凸台直径	Centering diameter output	D5	h7	60	80	110	130		
输出法兰对角线尺寸	Diagonal dimension output	D7		92	116	145	185		
输出端法兰外方	Flange cross section output	Q1	■	70	90	115	142		
总长	Total length	L1		137,5	165	218	273	1	
				185	207	248,5	342,5	2	
箱体长度	Housing length	L2		62,5	75	97	99	1	
				110	122,5	135,5	199	2	
输出轴轴长	Shaft length output	L3		32	41,5	64,5	87		
输出端定位凸台深度	Centering depth output	L7		3	3	4,5	5		
输出端法兰厚度	Flange thickness output	L8		7	8	10	20		
电机轴直径j6/k6	Motor shaft diameter j6/k6	D20		更多信息见第 163/164 页 More information on page 163/164					
输入端锁紧系统直径	Clamping system diameter input	D26							
带平键的输出轴 (DIN 6885-1)	Output shaft with feather key (DIN 6885-1)			A 6x6x20	A 6x6x28	A 10x8x50	A 12x8x65		A
平键宽度 (DIN 6885-1)	Feather key width (DIN 6885-1)	B1		6	6	10	12		
含平键在内的轴高 (DIN 6885-1)	Shaft height including feather key (DIN 6885-1)	H1		21,5	24,5	35	43		
到轴肩的距离	Shaft length from shoulder	L4		28	36	58	80		
平键长度	Feather key length	L5		20	28	50	65		
到轴端的距离	Distance from shaft end	L6		4	4	4	8		
中心孔 (DIN 332, DR 形)	Center hole (DIN 332, type DR)	C		M6x16	M8x19	M12x28	M16x36		
光滑输出轴	Smooth output shaft								B
到轴肩的距离	Shaft length from shoulder	L4		28	36	58	80		

⁽²⁾ 所有的尺寸单位为mm
⁽³⁾ 减速机级数

⁽²⁾ Dimensions in mm
⁽³⁾ Number of stages

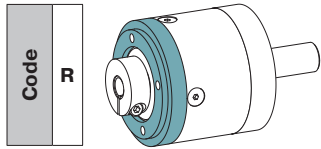

无适配电机法兰 – 圆形通用法兰

No motor adaptation – round universal flange

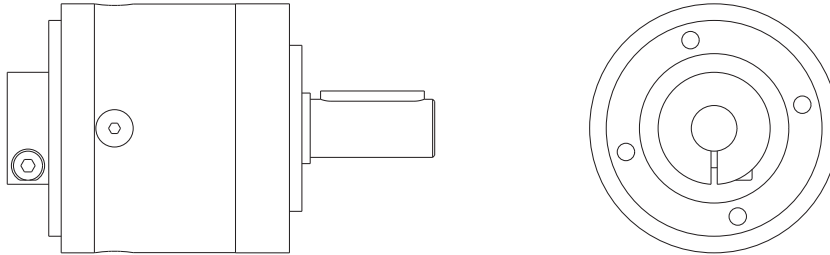

图示为带平键的 PLE060 / 1 级 / 附带平键的输出轴 / 11 mm 锁紧系统 / 无适配电机法兰 – 圆形通用法兰

Drawing corresponds to a PLE060 / 1-stage / output shaft with feather key / 11 mm clamping system / no motor adaptation – round universal flange

所有其它变量可在 www.neugart.com 下 Tec Data Finder 中检索 – All other variants can be retrieved in Tec Data Finder at www.neugart.com

这种输入系统的设计所适用的产品系列，规格尺寸和相关的锁紧系统会在163 -165页的产品编码显示。
相应的参数与尺寸可以从官网www.neugart.com中Tec Data Finder的技术数据表中获取。

This input design applies to the series, frame sizes, and associated clamping systems shown in the product code on pages 163-165.

The respective measurements can be taken from the technical data sheets in Tec Data Finder at www.neugart.com

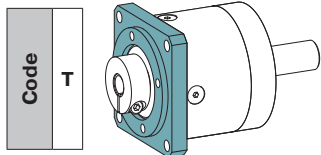

无适配电机法兰 – 方形通用法兰

No motor adaptation – square universal flange

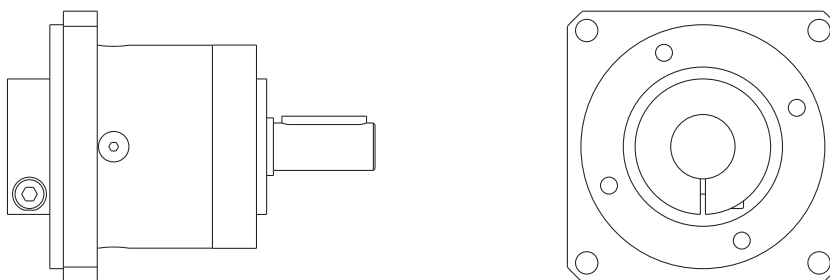

图示为带平键的 PLE060 / 1 级 / 附带平键的输出轴 / 19 mm 锁紧系统 / 无适配电机法兰 – 正方形通用法兰

Drawing corresponds to a PLE060 / 1-stage / output shaft with feather key / 19 mm clamping system / no motor adaptation – square universal flange

所有其它变量可在 www.neugart.com 下 Tec Data Finder 中检索 – All other variants can be retrieved in Tec Data Finder at www.neugart.com

这种输入系统的设计所适用的产品系列，规格尺寸和相关的锁紧系统会在163 -165页的产品编码显示。
相应的参数与尺寸可以从官网www.neugart.com中Tec Data Finder的技术数据表中获取。

This input design applies to the series, frame sizes, and associated clamping systems shown in the product code on pages 163-165.

The respective measurements can be taken from the technical data sheets in Tec Data Finder at www.neugart.com

系列 Series

	PLE	PLE 经济型行星减速机	PLE Economy planetary gearbox
	PLQE	PLQE 经济型行星减速机	PLQE Economy planetary gearbox
	PLPE	PLPE 经济型行星减速机	PLPE Economy planetary gearbox
	PLHE	PLHE 经济型行星减速机	PLHE Economy planetary gearbox
	PLFE	PLFE 经济型行星减速机	PLFE Economy planetary gearbox
	PFHE	PFHE 经济型行星减速机	PFHE Economy planetary gearbox
	WPLE	WPLE 经济型直角减速机	WPLE Economy right angle gearbox
	WPLQE	WPLQE 经济型直角减速机	WPLQE Economy right angle gearbox
	WPLPE	WPLPE 经济型直角减速机	WPLPE Economy right angle gearbox
	WPLHE	WPLHE 经济型直角减速机	WPLHE Economy right angle gearbox
	WPLFE	WPLFE 经济型直角减速机	WPLFE Economy right angle gearbox
	PSBN	PSBN 精密型行星减速机	PSBN Precision planetary gearbox
	PSN	PSN 精密型行星减速机	PSN Precision planetary gearbox
	PLN	PLN 精密型行星减速机	PLN Precision planetary gearbox
	PSFN	PSFN 精密型行星减速机	PSFN Precision planetary gearbox
	PLFN	PLFN 精密型行星减速机	PLFN Precision planetary gearbox
	WPLN	WPLN 精密型直角减速机	WPLN Precision right angle gearbox
	WPSFN	WPSFN 精密型直角减速机	WPSFN Precision right angle gearbox
	WGN	WGN 精密型直角减速机	WGN Precision right angle gearbox
	HLAE	HLAE 专用行星减速机	HLAE Application specific planetary gearbox
	NGV	NGV 专用行星减速机	NGV Application specific planetary gearbox

结构尺寸 Frame size

			PLE	PLQE	PLPE	PLHE	PLFE	PFHE	WPLE	WPLQE	WPLPE	WPLHE	WPLFE	PSBN	PSN	PLN	PSFN	PLFN	WPLN	WPSFN	WGN	HLAE	NGV	
040	结构尺寸 Frame size	40	•	•																				
050	结构尺寸 Frame size	50			•						•													
055	结构尺寸 Frame size	55					•							•	•		•							
060	结构尺寸 Frame size	60	•	•		•			•	•	•													
064	结构尺寸 Frame size	64					•	•				•									•			•
070	结构尺寸 Frame size	70			•						•			•	•	•				•		•	•	
080	结构尺寸 Frame size	80	•	•		•			•	•	•													
090	结构尺寸 Frame size	90			•		•	•			•	•	•	•	•	•	•	•	•	•	•	•	•	•
110	结构尺寸 Frame size	110					•	•				•									•		•	•
115	结构尺寸 Frame size	115												•	•	•				•		•	•	
120	结构尺寸 Frame size	120	•	•	•	•			•	•	•	•												
140	结构尺寸 Frame size	140															•	•			•			
142	结构尺寸 Frame size	142												•	•	•				•		•		
155	结构尺寸 Frame size	155			•																			
160	结构尺寸 Frame size	160	•																					
190	结构尺寸 Frame size	190													•	•								
200	结构尺寸 Frame size	200															•	•						

传动比 Ratio

			PLE	PLQE	PLPE	PLHE	PLFE	PFHE	WPLE	WPLQE	WPLPE	WPLHE	WPLFE	PSBN	PSN	PLN	PSFN	PLFN	WPLN	WPSFN	WGN	HLAE	NGV	
003	传动比 Ratio	i = 3	•	•	• ¹⁾	•	•	•	•	•	•	•	•	•	•	•	•	•	•	•	•	•	•	•
004	传动比 Ratio	i = 4	•	•	•	•	•	•	•	•	•	•	•	•	•	•	•	•	•	•	•	•	•	•
005	传动比 Ratio	i = 5	•	•	•	•	•	•	•	•	•	•	•	•	•	•	•	•	•	•	•	•	•	•
007	传动比 Ratio	i = 7	• ¹⁾	•	• ¹⁾	•	•	•	•	•	•	•	•	•	•	•	•	•	•	•	•	•	•	•
008	传动比 Ratio	i = 8	•	•	• ¹⁾	•	•	•	•	•	•	•	•	•	•	•	•	•	•	•	•	•	•	•
010	传动比 Ratio	i = 10	• ¹⁾	•	•	•	•	•	•	•	•	•	•	•	•	•	•	•	•	•	•	•	•	•
009	传动比 Ratio	i = 9	• ¹⁾	•	• ¹⁾	•	•	•	•	•	•	•	•	•	•	•	•	•	•	•	•	•	•	•
012	传动比 Ratio	i = 12	•	•	• ¹⁾	•	•	•	•	•	•	•	•	•	•	•	•	•	•	•	•	•	•	•
015	传动比 Ratio	i = 15	•	•	• ¹⁾	•	•	•	•	•	•	•	•	•	•	•	•	•	•	•	•	•	•	•
016	传动比 Ratio	i = 16	•	•	•	•	•	•	•	•	•	•	•	•	•	•	•	•	•	•	•	•	•	•
020	传动比 Ratio	i = 20	•	•	•	•	•	•	•	•	•	•	•	•	•	•	•	•	•	•	•	•	•	•
025	传动比 Ratio	i = 25	•	•	•	•	•	•	•	•	•	•	•	•	•	•	•	•	•	•	•	•	•	•
028	传动比 Ratio	i = 28																						
032	传动比 Ratio	i = 32	•	•	• ¹⁾	•	•	•	•	•	•	•	•	•	•	•	•	•	•	•	•	•	•	•
035	传动比 Ratio	i = 35												•	•	•				•		•	•	•
040	传动比 Ratio	i = 40	•	•	•	•	•	•	•	•	•	•	•	•	•	•	•	•	•	•	•	•	•	•
050	传动比 Ratio	i = 50			• ²⁾									•	•	•				•		•	•	•
064	传动比 Ratio	i = 64	•	•	• ¹⁾	•	•	•	•	•	•	•	•	•	•	•	•	•	•	•	•	•	•	•
070	传动比 Ratio	i = 70												•	•	•				•		•	•	•
060	传动比 Ratio	i = 60	• ¹⁾	•						•	•													
080	传动比 Ratio	i = 80	• ¹⁾	•						•	•													
100	传动比 Ratio	i = 100	• ¹⁾	•	•	•	•	•	•	•	•	•	•	•	•	•	•	•	•	•	•	•	•	•
120	传动比 Ratio	i = 120	• ¹⁾	•						•	•													
160	传动比 Ratio	i = 160	• ¹⁾	•						•	•													
200	传动比 Ratio	i = 200	• ¹⁾	•						•	•													
256	传动比 Ratio	i = 256	• ¹⁾	•						•	•													
320	传动比 Ratio	i = 320	• ¹⁾	•						•	•													
512	传动比 Ratio	i = 512	• ¹⁾	•						•	•													

参见下一页 See next page

结构尺寸 Frame size	PLE	PLQE	PLPE	PLHE	PLFE	PFHE	WPLE	WPLQE	WPLPE	WPLHE	WPLFE	PSBN	PSN	PLN	PSFN	PLFN	WPLN	WPSFN	WGN	HLAE	NGV	p ³⁾	输入端锁紧系统直径 Clamping system diameter input				
	40	40	50		55		40		50														1/2/3	8 mm	锁紧系统直径	Clamping system diameter	A
40	40	50		55		40		50														1/2/3	9 mm	锁紧系统直径	Clamping system diameter	B	
40	40	50	60	55	64	60	60	70	60	64		55	55		55						70	64	1	11 mm	锁紧系统直径	Clamping system diameter	C
60	60	70		64		60		70				55	55		55							2/3					
60	60	70	60	64	60	60	60	70	60	64		70	70	70	64	70	64	70			70	64	1	14 mm	锁紧系统直径	Clamping system diameter	D
												70	70	70	64	70	64	70				2/3					
60	60	70	60	64	60	60	60	70	60	64		70	70	70	64	70	64	70			90	64	1	19 mm	锁紧系统直径	Clamping system diameter	E
80	80	90	60	64	60	60	60	70	60	64		70	70	70	64	70	64	70			90	64	2/3				
80	80	90	60	64	60	60	60	70	60	64		70	70	70	64	70	64	70			90	64	1	24 mm	锁紧系统直径	Clamping system diameter	F
120	120	120	60	64	60	60	60	70	60	64		70	70	70	64	70	64	70			90	64	2/3				
120	120	120	60	64	60	60	60	70	60	64		70	70	70	64	70	64	70			90	64	1	35 mm	锁紧系统直径	Clamping system diameter	G
160	120	155										115	115	115	110	110	115	110	115	110	110	2/3					
		155										115	115	115	110	110	115	110	115	110	110	1	42 mm	锁紧系统直径	Clamping system diameter	H	
												142	142	142	140	140	142	140	142	140	140	2					
												142	142	142	140	140	142	140	142	140	140	1	48 mm	锁紧系统直径	Clamping system diameter	K	
												190	190	190	200	200	200	200	200	200	200	2					

PLE	PLQE	PLPE	PLHE	PLFE	PFHE	WPLE	WPLQE	WPLPE	WPLHE	WPLFE	PSBN	PSN	PLN	PSFN	PLFN	WPLN	WPSFN	WGN	HLAE	NGV	输入系统 Input system					
•	•	•	•	•	•	•	•	•	•	•	•	•	•	•	•	•	•	•	•	•	•	•	标准输入系统	Standard input system	A	
•	•	•	•	•	•	•	•	•	•	•	•	•	•	•	•	•	•	•	•	•	•	•	•	可安装的驱动系统	Mountable input system	S

PLE	PLQE	PLPE	PLHE	PLFE	PFHE	WPLE	WPLQE	WPLPE	WPLHE	WPLFE	PSBN	PSN	PLN	PSFN	PLFN	WPLN	WPSFN	WGN	HLAE	NGV	输出法兰规格 Output flange design				
•	•	•	•	•	•	•	•	•	•	•	•	•	•	•	•	•	•	•	•	•	•	•	标准输出法兰	Standard output flange	3
•	•	•	•	•	•	•	•	•	•	•	•	•	•	•	•	•	•	•	•	•	•	•	可兼容 (W)PLS 的输出法兰	Output flange (W)PLS-compatible	4

PLE	PLQE	PLPE	PLHE	PLFE	PFHE	WPLE	WPLQE	WPLPE	WPLHE	WPLFE	PSBN	PSN	PLN	PSFN	PLFN	WPLN	WPSFN	WGN	HLAE	NGV	p ³⁾	输出轴规格 Output shaft design			
•	•	•	•	•	•	•	•	•	•	•	•	•	•	•	•	•	•	•	•	•	•	1/2/3	附带平键的输出轴 (DIN 6885 - 1)	Output shaft with feather key (DIN 6885-1)	A
•	•	•	•	•	•	•	•	•	•	•	•	•	•	•	•	•	•	•	•	•	•	1/2/3	光滑输出轴	Smooth output shaft	B
•	•	•	•	•	•	•	•	•	•	•	•	•	•	•	•	•	•	•	•	•	•	1/2	花键输出轴 (DIN 5480)	Splined output shaft (DIN 5480)	C
•	•	•	•	•	•	•	•	•	•	•	•	•	•	•	•	•	•	•	•	•	•	1	法兰输出轴	Flange output shaft	D
•	•	•	•	•	•	•	•	•	•	•	•	•	•	•	•	•	•	•	•	•	•	2	带有配合销孔的法兰输出轴	Flange output shaft with dowel hole	E
•	•	•	•	•	•	•	•	•	•	•	•	•	•	•	•	•	•	•	•	•	•	1	单侧空心输出轴	Hollow output shaft on one side	F
•	•	•	•	•	•	•	•	•	•	•	•	•	•	•	•	•	•	•	•	•	•	1	双侧空心输出轴	Hollow output shaft on both sides	G
•	•	•	•	•	•	•	•	•	•	•	•	•	•	•	•	•	•	•	•	•	•	1	法兰输出轴, 配有定位销孔	Flange output hollow shaft with dowel hole	H
•	•	•	•	•	•	•	•	•	•	•	•	•	•	•	•	•	•	•	•	•	•	2	带小齿轮的花键输出轴 (DIN 5480)	Splined output shaft (DIN 5480) with mounted pinion	K
•	•	•	•	•	•	•	•	•	•	•	•	•	•	•	•	•	•	•	•	•	•	1/2	装有小齿轮的法兰输出轴	Flange output shaft with mounted pinion	M

PLE	PLQE	PLPE	PLHE	PLFE	PFHE	WPLE	WPLQE	WPLPE	WPLHE	WPLFE	PSBN	PSN	PLN	PSFN	PLFN	WPLN	WPSFN	WGN	HLAE	NGV	表面 Surface				
•	•	•	•	•	•	•	•	•	•	•	•	•	•	•	•	•	•	•	•	•	•	•	标准表面	Standard surface	S
•	•	•	•	•	•	•	•	•	•	•	•	•	•	•	•	•	•	•	•	•	•	•	喷漆表面 — RAL 9005 黑色	Painted surface - RAL 9005 jet black	B

PLE	PLQE	PLPE	PLHE	PLFE	PFHE	WPLE	WPLQE	WPLPE	WPLHE	WPLFE	PSBN	PSN	PLN	PSFN	PLFN	WPLN	WPSFN	WGN	HLAE	NGV	润滑 Lubrication				
•	•	•	•	•	•	•	•	•	•	•	•	•	•	•	•	•	•	•	•	•	•	•	标准润滑	Standard lubrication	S
•	•	•	•	•	•	•	•	•	•	•	•	•	•	•	•	•	•	•	•	•	•	•	食品级润滑	Food grade lubrication	F
•	•	•	•	•	•	•	•	•	•	•	•	•	•	•	•	•	•	•	•	•	•	•	低温润滑	Low temperature lubrication	L

PLE	PLQE	PLPE	PLHE	PLFE	PFHE	WPLE	WPLQE	WPLPE	WPLHE	WPLFE	PSBN	PSN	PLN	PSFN	PLFN	WPLN	WPSFN	WGN	HLAE	NGV	p ³⁾	回程间隙 Torsional backlash			
•	•	•	•	•	•	•	•	•	•	•	•	•	•	•	•	•	•	•	•	•	•	1/2/3	标准回程间隙	Standard backlash	S
•	•	•	•	•	•	•	•	•	•	•	•	•	•	•	•	•	•	•	•	•	•	1	降低回程间隙	Reduced backlash	R
•	•	•	•	•	•	•	•	•	•	•	•	•	•	•	•	•	•	•	•	•	•	2			

¹⁾无法提供安装尺寸为155或160的减速机 - Not for frame size 155 or 160 ²⁾不适用于结构尺寸 50, 70, 90, 120 - Not for frame sizes 50, 70, 90, 120 ³⁾减速机级数 - Number of stages

输入系统规格 Input design

输入系统规格 Input design



	PLE	PLQE	PLPE	PLHE	PLFE	PFHE	WPLE	WPLQE
Z 适配电机法兰 - 2 件式 - 圆形通用法兰 Motor adaptation - 2 part - round universal flange	60 (11/14) 80 (19) 120 (24)	60 (11/14) 80 (19) 120 (24)	70 (11/14) 90 (19) 120 (24)	60 (11/14) 80 (19) 120 (24)	64 (11/14) 90 (19) 110 (24)	64 (11/14) 90 (19) 110 (24)		
Y 适配电机法兰 - 2 件式 - 方形通用法兰 Motor adaptation - 2 part - square universal flange	40 (8/9/11) 60 (19) 80 (24) 120 (35) 160 (35)	40 (8/9/11) 60 (19) 80 (24) 120 (35) 160 (35)	50 (8/9/11) 70 (19) 90 (24) 120 (35) 155 (35/42)	60 (19) 80 (24) 120 (35)	50 (8/9/11) 55 (8/9/11) 64 (19) 90 (24) 110 (35)	64 (19) 90 (24) 110 (35)	40 (8/9) 60 (11/14) 80 (19) 120 (24)	60 (11/14) 80 (19) 120 (24)
E 适配电机法兰 - 单一法兰 Motor adaptation - one part	40 (8/9) 60 (11/14) 80 (19) 120 (24) 160 (35)	40 (8/9) 60 (11/14) 80 (19) 120 (24)	50 (8/9) 70 (11/14) 90 (19) 120 (24) 155 (35)	60 (11/14) 80 (19) 120 (24)	55 (8/9) 64 (11/14) 90 (19) 110 (24)	64 (11/14) 90 (19) 110 (24)		
R 无适配电机法兰 - 圆形通用法兰 ¹⁾ No motor adaptation - round universal flange ¹⁾	60 (11/14) 80 (19) 120 (24)	60 (11/14) 80 (19) 120 (24)	70 (11/14) 90 (19) 120 (24)	60 (11/14) 80 (19) 120 (24)	64 (11/14) 90 (19) 110 (24)	64 (11/14) 90 (19) 110 (24)		
T 无适配电机法兰 - 方形通用法兰 ¹⁾ No motor adaptation - square universal flange ¹⁾	40 (8/9/11) 60 (19) 80 (24) 120 (35) 160 (35)	40 (8/9/11) 60 (19) 80 (24) 120 (35) 160 (35)	50 (8/9/11) 70 (19) 90 (24) 120 (35) 155 (35/42)	60 (19) 80 (24) 120 (35)	55 (8/9/11) 64 (19) 90 (24) 110 (35)	64 (19) 90 (24) 110 (35)	40 (8/9) ²⁾ 60 (11/14) ³⁾ 80 (19) ³⁾ 120 (24) ³⁾	60 (11/14) ³⁾ 80 (19) ³⁾ 120 (24) ³⁾

- ¹⁾ 产品代码在输入“电机轴直径”后结束 - The product code ends after “motor shaft diameter” has been entered
- ²⁾ 仅带有通孔的直角齿轮箱 - Angle only with through hole
- ³⁾ 紧带有螺纹孔的直角齿轮箱 - Angle only with thread

电机轴直径 Motor shaft diameter	对于“锁紧系统直径” For "clamping system diameter"										电机轴直径 Motor shaft diameter	最大电机轴长 [mm] Max. motor shaft length [mm]	定位凸台直径 [mm] Centering diameter [mm]	节圆直径 [mm] Pitch circle diameter [mm]	电机法兰类型 Flange type motor
	8	9	11	14	19	24	35	42	48						
4															
5															
6															
6.35															
7															
8															
9															
9.5															
9.525															
10															
11															
12															
12.7															
14															
15.875															
16															
19															
19.05															
20															
22															
24															
28															
32															
35															
38															
42															
48															

最大电机轴长 [mm] Max. motor shaft length [mm]

最大允许的电机轴长 Max. permissible motor shaft length
→ 任意文本 - 长度数据无小数点 Free text - length without decimal places

定位凸台直径 [mm] Centering diameter [mm]

定位凸台直径 Centering diameter
→ 任意文本 - 最多2位小数 Free text - length to max. two decimal places

节圆直径 [mm] Pitch circle diameter [mm]

节圆直径 Pitch circle diameter
→ 任意文本 - 最多1位小数 Free text - length to max. one decimal place

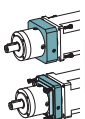

电机法兰类型 Flange type motor

B5 B5 电机法兰类型 B5 Flange type motor

B14 B14 电机法兰类型 B14 Flange type motor

PLE	PLQE	PLPE	PLHE	PLFE	PFHE	WPLE	WPLQE	WPLPE	WPLHE	WPLFE	PSBN	PSN	PLN	PSFN	PLFN	WPLN	WPSFN	WGN	NGV	HLAE
•	•	•	•	•	•	•	•	•	•	•	•	•	•	•	•	•	•	•	•	•
•	•	•	•	•	•	•	•	•	•	•	•	•	•	•	•	•	•	•	•	•
请联系确认 Available upon inquiry																				

¹⁾ 无法提供安装尺寸为 055 - Not for frame size 55

/ M5 - PK1 - 20 - 18 - S

WPLPE	WPLHE	WPLFE	PSBN	PSN	PLN	PSFN	PLFN	WPLN	WPSFN	WGN	HLAE	NGV
			55 (11/14) 70 (11/14/19) 90 (11/14/19/24) 115 (14/19/24/35) 142 (19/24/35/42)	55 (11/14) 70 (11/14/19) 90 (11/14/19/24) 115 (14/19/24/35) 142 (19/24/35/42) 190 (35/42/48)	70 (14/19) 90 (19/24) 115 (24)	55 (11/14) 64 (11/14/19) 90 (11/14/19/24) 110 (14/19/24/35) 140 (19/24/35/42) 200 (35/42/48)	64 (14/19) 90 (14/19/24) 110 (19/24) 140 (24) 200 (48)	70 (14/19) 90 (14/19/24) 115 (19/24) 142 (24)	64 (14/19) 90 (14/19/24) 110 (19/24) 140 (24)	70 (14/19) 90 (19/24) 115 (24)	70 (11/14) 90 (19) 110 (24)	64 (11/14) 90 (19) 110 (24)
50 (8/9) 70 (11/14) 90 (19) 120 (24)	60 (11/14) 80 (19) 120 (24)	60 (11/14) 90 (19) 110 (24)			115 (35) 142 (35/42) 190 (48)		110 (35) 140 (35/42) 200 (35/42)	115 (35) 142 (35/42)	110 (35) 140 (35/42)	115 (35) 142 (35/42)		64 (19) 90 (24) 110 (35)
											70 (11/14) 90 (19) 110 (24)	64 (11/14) 90 (19) 110 (24)
					70 (14/19) 90 (19/24) 115 (24)		64 (14/19) 90 (14/19/24) 110 (19/24) 140 (24) 200 (48)	70 (14/19) 90 (14/19/24) 115 (19/24) 142 (24)	64 (14/19) 90 (14/19/24) 110 (19/24) 140 (24)	70 (14/19) 90 (19/24) 115 (24)		64 (11/14) 90 (19) 110 (24)
50 (8/9) ² 70 (11/14) ³ 90 (19) ³ 120 (24) ³	60 (11/14) ³ 80 (19) ³ 120 (24) ³	64 (11/14) ³ 90 (19) ³ 110 (24) ³			115 (35) 142 (35/42) 190 (48)		110 (35) 140 (35/42) 200 (35/42)	115 (35) 142 (35/42)	110 (35) 140 (35/42)	115 (35) 142 (35/42)		64 (19) 90 (24) 110 (35)

/ M5 - PK1 - 20 - 18 - S



PK1	PM1	PM2	齿轮类型	Helix angle
•		•	直齿齿轮	Spur pinion L
•	•	•	斜齿齿轮	Helical pinion S

齿数 Number of teeth

可用的齿数以及组合方式，详见第134页和第136页138页
Available number of teeth and possible combinations see pages 134, 136 and 138

模数 Module

15	模数 1,5	Module 1,5
20	模数 2	Module 2
30	模数 3	Module 3
40	模数 4	Module 4
50	模数 5	Module 5

的组合方式，详见第134页和第136页138页
Detailed possible combinations see pages 134, 136 and 138

PLE	PLQE	PLPE	PLHE	PLFE	PFHE	WPLE	WPLQE	WPLPE	WPLHE	WPLFE	PSBN	PSN	PLN	PSFN	PLFN	WPLN	WPSFN	WGN	HLAE	NGV	小齿轮型号	Pinion type	
		•	•						•		•	•				•						花键输出轴的小齿轮 Pinion for splined output shaft	PK1
					•									•	•		•					法兰输出轴的小齿轮 Pinion for flange output shaft	PM1
					•									•	•		•					法兰输出轴的小齿轮 Pinion for flange output shaft	PM2

电机安装螺纹 Mounting thread

M2	M2	电机安装螺纹	Mounting thread
M3	M3	电机安装螺纹	Mounting thread
M4	M4	电机安装螺纹	Mounting thread
M5	M5	电机安装螺纹	Mounting thread
M6	M6	电机安装螺纹	Mounting thread
M8	M8	电机安装螺纹	Mounting thread
M10	M10	电机安装螺纹	Mounting thread
M12	M12	电机安装螺纹	Mounting thread
M16	M16	电机安装螺纹	Mounting thread

最大的可传递输出扭矩

计算减速机齿部的使用寿命时，需区分疲劳强度和持久强度。参见图表

疲劳强度

所有 Neugart 公司的行星齿轮减速机都是专为高耐久性的使用条件而设计的（在规定的额定扭矩 T_{2N} 之内）。

可随时达到指定的负载数据，减速机齿部不会出现故障。

持久强度

基于指定的额定扭矩 T_{2N} ，进行断续运行时，还可以传输短时间的扭矩峰值或过高的使用扭矩。

最大使用扭矩 $T_{2使用}$ 的计算

- * 出现过高的使用扭矩时确定“输出轴转数”的总和。
- * 通过图表得出最大增强系数 f 。
- * 可算出最大可传输的使用扭矩 $T_{2max_允许_使用}$

$$T_{2max_允许_使用} = f \times T_{2N}$$

- * 最大使用扭矩 $T_{2使用}$ 不得超过已得出的变速器最大输出扭矩 $T_{2max_允许_使用}$ 。

$$T_{2max_允许_使用} \geq T_{2使用}$$

增强系数 f 取决于“输出轴转数”的总和

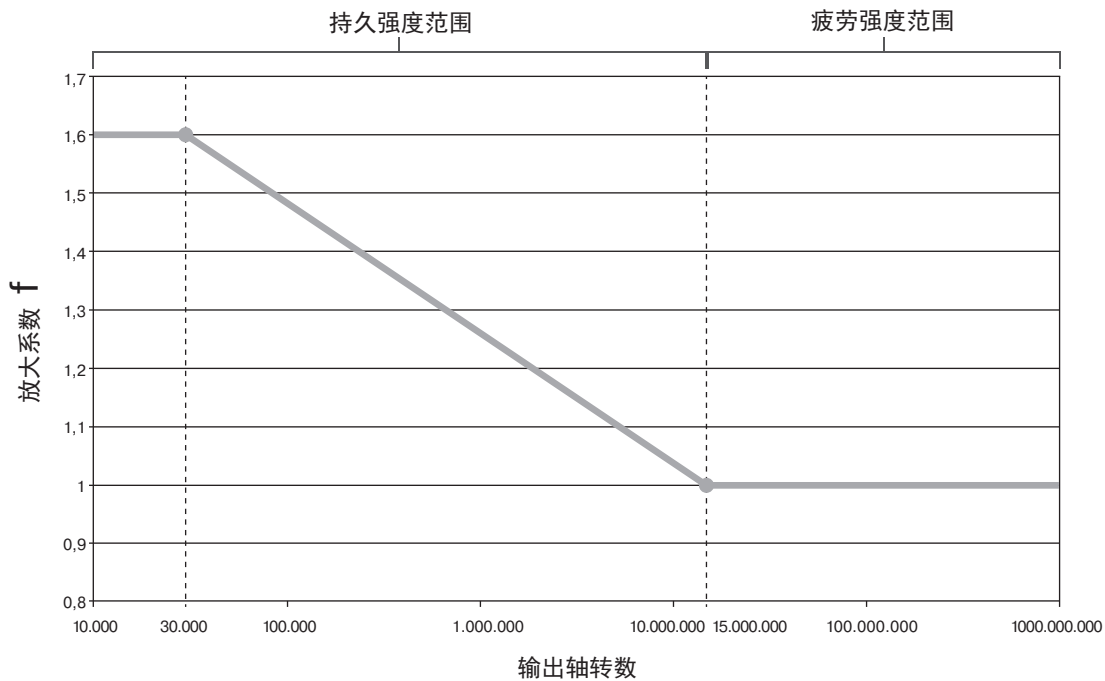

环境条件

用于散热设计的以下环境条件是设置目录值的基础：

- * 电机不加热减速机
- * 凸缘板（使用侧）：
 - 方形的平板 = 2 x 减速机输出端法兰外方尺寸
 - 材料：钢
- * 机座上的板连接：单侧 20°C
- * 不妨碍减速机的对流
- * 环境温度：20°C

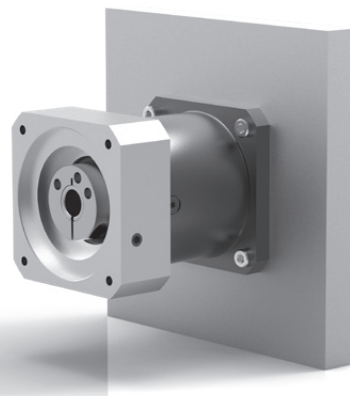

利用 NCP 针对应用进行专门设计 – www.neugart.com

Max. transferable output torque

Calculations of gear teeth service lives differentiate between long life and finite life. See diagram.

Long life

All Neugart planetary gearboxes are designed for the long life range within the specified nominal torques T_{2N} . The load specifications can be reached any number of times without the gear teeth failing.

Finite life

Intermittent duty may transfer brief torque peaks or increased application factors that exceed the specified nominal torque T_{2N} .

Calculating the max application torque $T_{2\text{application}}$

- * The total output shaft rotations under the increased application torques are determined.
- * The resulting max increase factor f can be determined from the diagram.
- * The max transferable application torque $T_{2\text{max_application}}$ is calculated:

$$T_{2\text{max_application}} = f \times T_{2N}$$

- * The application torque $T_{2\text{application}}$ may not exceed the gearbox's calculated max application torque $T_{2\text{max_application}}$

$$T_{2\text{max_application}} \geq T_{2\text{application}}$$

Increase factor f as a function of the total "output shaft rotations"

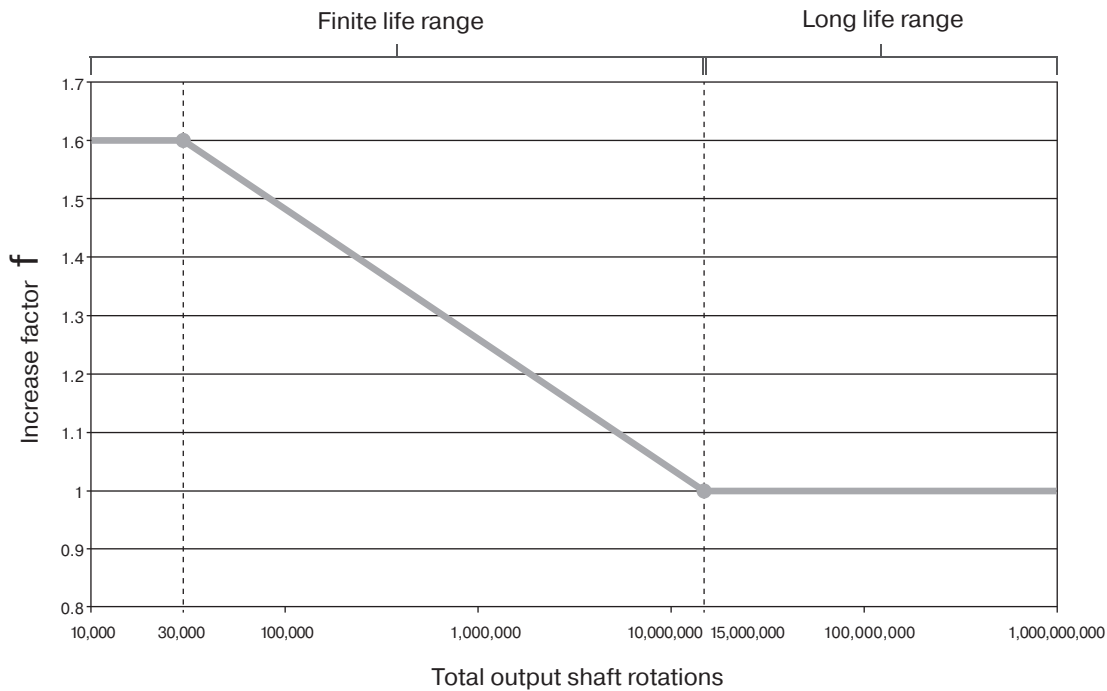

Ambient conditions

The following ambient conditions for the thermal design serve as the basis for the catalog values:

- * The motor does not heat up the gearbox
- * Flange mounted plate (application side):
 - Square plate = 2 x gearbox flange cross section at output
 - Material: steel
- * Plate connected via machine bed: 20°C on one side
- * No hindrance to gearbox convection
- * Ambient temperature: 20°C

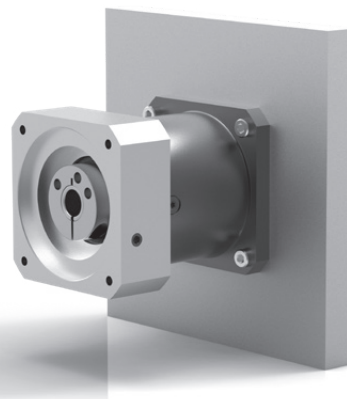

Application specific configuration with NCP – www.neugart.com



集团总部
Group Headquarters
Neugart GmbH
Keltenstraße 16
77971 Kippenheim
Phone: +49 7825 847-0
Fax: +49 7825 847-2999
Email: sales@neugart.com
Web: www.neugart.com/de-de



美国分公司
USA Headquarters
Neugart USA Corp.
14325 South Lakes Drive
Charlotte, NC 28273
Phone: +1 980 299-9800
Fax: +1 980 299-9799
Email: sales@neugartusa.com
Web: www.neugart.com/en-us



中国分公司
China Headquarters
Neugart Planetary Gearboxes (Shenyang)
Co., Ltd
No. 152-1, 22nd road
E&T Development Zone Shenyang,
PC 110143
Phone: +86 24 2537-4959
Fax: +86 24 2537-2552
Email: sales@neugart.net.cn
Web: www.neugart.net.cn



意大利总部
Italy Headquarters
Neugart Italia S.r.l.
Via Dr. Streiter 32
39100 Bolzano
Phone: +39 011 640 8248
Fax: +39 011 640 6205
Email: commerciale@neugart.it
Web: www.neugart.com/it-it



法国总部
France Headquarters
Neugart France S.A.S.
28 rue Schweighaeuser
67000 Strasbourg
Phone: +33 3 30 67 35 59
Fax: +49 7825 847-2999
Email: sales@neugart.fr
Web: www.neugart.com/fr-fr



土耳其总部
Turkey Headquarters
Neugart Redüktör San. Tic. Ltd. Şti
Burhaniye Mah. Atilla Sk. No:12
34676 Beylerbeyi – Üsküdar / İstanbul
Phone: +90 216 639 4050
Fax: +90 216 639 4052
Email: sales@neugart.com.tr
Web: www.neugart.com/tr-tr



瑞士总部
Switzerland Headquarters
Neugart Schweiz AG
c/o Walder Wyss
Seefeldstrasse 123
8008 Zürich
Phone: +41 44 515 56 05
Email: sales@neugart.ch
Web: www.neugart.com



巴西总部
Brazil Headquarters
Neugart do Brasil
Equipamentos Industriais Ltda
Acesso José Sartorelli,
km 2,1 - Prédio 1 Ala B,
Parque das Árvores
SP CEP 18555-225 Boituva
Phone: +55 15 3363-9910
Fax: +55 15 3363-9911
Email: comercial@neugart.com.br
Web: www.neugart.com/pt-br



德国
Germany Baden-Wuerttemberg
Martin Schiewe
77948 Friesenheim
Phone: +49 151 18817659
Email: martin.schiewe@neugart.com
Web: www.neugart.com/de-de



德国
Germany Baden-Wuerttemberg
Thomas Malig
76275 Ettlingen
Phone: +49 151 18812756
Email: thomas.malig@neugart.com
Web: www.neugart.com/de-de



德国
Germany Baden-Wuerttemberg
Thomas Strähle
72766 Reutlingen
Phone: +49 151 18812754
Email: thomas.straehle@neugart.com
Web: www.neugart.com/de-de



德国
Germany Bavaria
Dominik Bretschneider
83666 Waakirchen
Phone: +49 151 18817495
Email: dominik.bretschneider@neugart.com
Web: www.neugart.com/de-de



德国
Germany Bavaria
Ronny Jäger
97688 Bad Kissingen
Phone: +49 151 18817641
Email: ronny.jaeger@neugart.com
Web: www.neugart.com/de-de



德国中部/德国西部
Central Germany/Western Germany
Hans-Jürgen Becker
63739 Aschaffenburg
Phone: +49 151 18812750
Email: hans-juergen.becker@neugart.com
Web: www.neugart.com/de-de



德国北部/德国西部
Northern Germany/Western Germany
Marco Stührenberg
32758 Detmold
Phone: +49 151 18812751
Email: marco.stuehrenberg@neugart.com
Web: www.neugart.com/de-de



德国东部
Eastern Germany
Sebastian Gruner
09224 Chemnitz
Phone: +49 151 18817647
Email: sebastian.gruner@neugart.com
Web: www.neugart.com/de-de



奥地利/Austria

BIBUS Austria GmbH
Eduard-Klinger-Straße 12
3423 St. Andrä-Wördern
Phone: +43 2242 33388-0
Fax: +43 2242 33388-101
Email: info@bibus.at
Web: www.bibus.at



比利时/Belgium

Automotion
Bilksken 36
9920 Lovendegem
Phone: +32 93 705555
Fax: +32 93 705550
Email: info@automotion.be
Web: www.automotion.be



捷克/Czech Republic

TAT – POHONOVÁ TECHNIKA s.r.o.
370 06 České Budějovice
Hraniční 2253
Phone: +420 387 414-414
Fax: +420 387 414-415
Email: tat@cz.tat.at
Web: www.tat.cz



丹麦/Denmark

ServoTech A/S
Ulvehavevej 44B
7100 Vejle
Phone: +45 7942 80 80
Email: sales@servotech.dk
Web: www.servotech.dk



芬兰/Finland

Oy Movetec Ab
Suokalliontie 9
01740 Vantaa
Phone: +358 9 5259-230
Fax: +358 9 5259-2333
Email: info@movetec.fi
Web: www.movetec.fi



法国/France

Neugart France S.A.S.
28 rue Schweighaeuser
67000 Strasbourg
Phone: +33 3 30 67 35 59
Fax: +49 7825 847-2999
Email: sales@neugart.fr
Web: www.neugart.com/fr-fr



希腊/Greece

KYMA Automation
Mesaio 54500
Thessaloniki
Phone: +30 2310 786002
Fax: +30 2310 011812
Email: info@kyma-automation.gr
Web: www.kyma-automation.gr



意大利/Italy

Neugart Italia S.r.l.
Via Dr. Streiter 32
39100 Bolzano
Phone: +39 011 640 8248
Fax: +39 011 640 6205
Email: commerciale@neugart.it
Web: www.neugart.com/it-it



荷兰/Netherlands

Caldic Techniek B.V.
Schuttevaerweg 60
3044 BB Rotterdam
Phone: +31 104 156622
Fax: +31 104 378810
Email: info@caldic-techniek.nl
Web: www.caldic.com



荷兰/Netherlands

ABI b.v.
Minckelersweg 22
2031 EM Haarlem
Phone: +31 23 531 9292
Fax: +31 23 532 6599
Email: info@abi.nl
Web: www.abi.nl



挪威/Norway

Aratron AS
Bjørnerudveien 17
1266 Oslo
Phone: +47 23 19 1660
Fax: +47 23 19 1661
Email: firmapost@aratron.no
Web: www.aratron.no



波兰/Poland

P.P.H. WObit E.K.J. Ober s.c.
Dęborzyce 16
62-045 Pniewy
Phone: +48 61 2227-410
Fax: +48 61 2227-439
Email: wobit@wobit.com.pl
Web: www.wobit.com.pl



葡萄牙/Portugal

Equinotec - Soluções de Engenharia,
Unipessoal, Lda.
Rua D.Marcos da Cruz, 1677
4455-482 Perafita, Matosinhos
Portugal
Phone: +351 229 350 755
Email: comercialnorte@equinotec.com
Web: www.equinotec.com



葡萄牙/Portugal

Powertech System SL
C Italia 11 - Nave 9
08700 Igualada (Cataluña)
Phone: +34 938 056021
Email: rubengarcia@powertecsys.com
Web: www.powertecsys.com



斯洛文尼亚/Slovenia

MB-NAKLO d.o.o
Ulica Toma Zupana 16
4202 Naklo
Slovenija
Phone: +386 4 277 17 00
Fax: +386 4 277 17 17
Email: info@mb-naklo.si
Web: www.mb-naklo.si



西班牙/Spain

Powertech System SL
C Italia 11 - Nave 9
08700 Igualada (Cataluña)
Phone: +34 938 056021
Email: rubengarcia@powertecsys.com
Web: www.powertecsys.com



瑞典/Sweden

SDT Scandinavian Drive Technologies
Sabelgatan 4
254 67 Helsingborg
Phone: +46 42 380800
Fax: +46 42 380813
Email: info@sdt.se
Web: www.sdt.se



瑞士/Switzerland

Neugart Schweiz AG
c/o Walder Wyss
Seefeldstrasse 123
8008 Zürich
Phone: +41 44 515 56 05
Email: sales@neugart.ch
Web: www.neugart.com



英国/United Kingdom

HMK Automation Group Ltd
Kappa House, Hatter Street
Congleton
Cheshire CW12 1QJ
Phone: +44 1260 279411
Fax: +44 1260 281022
Email: sales@hmkdirect.com
Web: www.hmkdirect.com



土耳其/Turkey

Neugart Redüktör San. Tic. Ltd. Şti
Burhaniye Mah. Atilla Sk. No:12
34676 Beylerbeyi – Üsküdar / İstanbul
Phone: +90 216 639 4050
Fax: +90 216 639 4052
Email: sales@neugart.com.tr
Web: www.neugart.com/tr-tr



巴西/阿根廷 Brazil/Argentina

Neugart do Brasil
Equipamentos Industriais Ltda
Acesso José Sartorelli,
km 2,1 - Prédio 1 Ala B,
Parque das Árvores
SP CEP 18555-225 Boituva
Phone: +55 15 3363-9910
Fax: +55 15 3363-9911
Email: comercial@neugart.com.br
Web: www.neugart.com/pt-br



中国分公司/China

Neugart Planetary Gearboxes (Shenyang)
Co., Ltd.
No. 152-1, 22nd road
E&T Development Zone Shenyang,
PC 110143
Phone: +86 24 2537-4959
Fax: +86 24 2537-2552
Email: sales@neugart.net.cn
Web: www.neugart.net.cn



印度/India

Fluro Engineering PVT. Ltd.
Plot No.B-29/1, MIDC,
Taloja, Dist. Raigad,
Navi Mumbai - 410208
Maharashtra
Phone: +91 22 2741-1922, 2740-1153
Email: sales@fluroengg.com
Web: www.fluroengg.com



以色列/Israel

SUZIN TRANSMISSION SYSTEM LTD.
HaTa'asiya 47 St.
3688847 Nesher
Phone: +972 4 8724148, 8725708
Fax: +972 4 8414284
Web: www.suzin.co.il



韩国/South Korea

Intech Automation Inc.
135, Jeongnamsandan-ro,
Jeongnam-myeon, Hwaseong-si,
Gyeonggi-do, 18514 Republic of Korea
Phone: +82 31 377 1030
Email: intech@intechautomation.co.kr
Web: www.intechautomation.co.kr



土耳其/Turkey

Neugart Redüktör San. Tic. Ltd. Şti
Burhaniye Mah. Atilla Sk. No:12
34676 Beylerbeyi – Üsküdar / İstanbul
Phone: +90 216 639 4050
Fax: +90 216 639 4052
Email: sales@neugart.com.tr
Web: www.neugart.com/tr-tr

Explanation of technical features



Economy Line

用实惠的价格达到令人满意的精确度。经济实惠且性价比超高的减速机系列。这一经济实惠的产品系列具备较高的精确度，回程间隙可达6弧分，功率高。这一系列产品有多种型号，可以根据具体情况灵活地调整。

Precision at an attractive price. The economical gearbox model series with an outstanding price/performance ratio. The Economy model series impresses with high precision of up to 6 arcmin of torsional backlash and a high performance density, a wide range of variants and numerous adaptation options.



精密型 Precision Line

精密型 适合于所有追求精确度的客户。回程间隙从 3 弧分到 1 弧分（可选），可以达到最高的精确度。特殊的轴承与密封技术，以及笼状结构的行星齿轮架，使得精密型的功率再上一层楼。低震动、高性能的装有准双曲面齿的直角型减速机使得这一产品系列得到完善。

The Precision Line is suitable for anyone who wants precision. The standard torsional backlash of 3 arcmin and optionally 1 arcmin provides maximum precision for the application. Special bearing and gasket technologies and cage-type planetary carriers increase the performance of the Precision Line. The model series is completed by special low-vibration and high-performance right angle gearboxes with hypoid teeth.



针对特定应用的减速机 Application-specific gearbox

根据特定应用的要求，我们对这些减速机做出了优化。因此，卫生型设计减速机 HLAE 能够满足食品与药品领域极为敏感的要求。如果用在工业地面运输车上，NGV 高精度减速器的智能设计，采用合适的轮子，同时提供了具备附加值的解决方案。

These gearboxes are optimized for specific requirements. Hygienic Design gearboxes meet the sensitive requirements in the food and pharmaceutical sectors. For use in industrial trucks, the intelligent design of the NGV planetary gearbox with matching wheel offers a solution with added value.

导航帮助:
在接下来的页面中，您将看到我们减速机的详细说明。

Navigation aid:
On the following pages you will find detailed explanations of the technical features of our gearboxes.

传输方向

Transmission direction



同轴减速机 Coaxial gearbox

驱动轴与输出轴位于一条线上。

The input and the output shafts are in a straight line.



直角型减速机 Right angle gearbox

驱动轴与输出轴互为 90°。

The input shaft and the output shaft are offset from each other by 90°.

旋转方向

Rotation direction



旋转方向 同方向 Equidirectional rotation

驱动轴与输出轴的旋转方向相同。

The input and the output shaft rotate in the same direction.



旋转方向 反方向 Counterdirectional rotation

驱动轴与输出轴的旋转方向相反。

The drive shaft and the output shaft rotate in opposite directions.

齿轮 Gearing



直齿 Spur gear

采用直齿设计，传输的转矩达到最高。因此，减速机的功率显著地提升。

Maximum torques can be transmitted with straight teeth. This significantly increases the performance density of the gearbox.



斜齿 Helical gear

斜齿减少了运行时的噪音。振动被降至最低程度。如此一来，在加工机床应用中，可以提高表面质量。

Helical teeth reduce the amount of operating noise. Vibration is reduced to a minimum. The surface quality is therefore increased when used in processing machines.



经济型
Economy Line

用实惠的价格达到令人满意的精度。经济实惠且性价比超高的减速机系列。这一经济实惠的产品系列具备较高的精度，回程间隙可达6弧分，功率高。这一系列产品有多种型号，可以根据具体情况灵活地调整。

Precision at an attractive price. The economical gearbox model series with an outstanding price/performance ratio. The Economy model series impresses with high precision of up to 6 arcmin of torsional backlash and a high performance density, a wide range of variants and numerous adaptation options.



精密型
Precision Line

精密型 适合于所有追求精度的客户。回程间隙从 3 弧分到 1 弧分（可选），可以达到最高的精度。特殊的轴承与密封技术，以及笼状结构的行星齿轮架，使得 精密型 的功率再上一层楼。低振动、高性能的装有准双曲面齿的直角型减速机使得这一产品系列得到完善。

The Precision Line is suitable for anyone who wants precision. The standard torsional backlash of 3 arcmin and optionally 1 arcmin provides maximum precision for the application. Special bearing and gasket technologies and cage-type planetary carriers increase the performance of the Precision Line. The model series is completed by special low-vibration and high-performance right angle gearboxes with hypoid teeth.



针对特定应用的减速机
Application-specific gearbox

根据特定应用的要求，我们对这些减速机做出了优化。因此，卫生型设计减速机 HLAE 能够满足食品与药品领域极为敏感的要求。如果用在工业地面运输车上，NGV 高精度减速机的智能设计，采用合适的轮子，同时提供了具备附加值的解决方案。

These gearboxes are optimized for application-specific requirements. Hygienic Design gearboxes meet the sensitive requirements in the food and pharmaceutical sectors. For use in industrial fork lift trucks, the clever concept of the NGV planetary gearbox with matching wheel offers a solution with added value.

传输方向 Transmission direction



同轴减速机
Coaxial gearbox

驱动轴与输出轴位于一条线上。

The input and the output shafts are in a straight line.



直角型减速机
Right angle gearbox

驱动轴与输出轴互为 90°。

The input shaft and the output shaft are offset from each other by 90°.

旋转方向 Rotation direction



旋转方向 同方向
Equidirectional rotation

驱动轴与输出轴的旋转方向相同。

The input and the output shaft rotate in the same direction.



旋转方向 反方向
Counterdirectional rotation

驱动轴与输出轴的旋转方向相反。

The drive shaft and the output shaft rotate in opposite directions.

齿轮 Gearing



直齿
Spur gear

采用直齿设计，传输的转矩达到最高。因此，减速机的功率显著地提升。

Maximum torques can be transmitted with straight teeth. This significantly increases the performance density of the gearbox.



斜齿
Helical gear

斜齿减少了运行时的噪音。振动被降至最低程度。如此一来，在加工机床应用中，可以提高表面质量。

Helical teeth reduce the amount of operating noise. Vibration is reduced to a minimum. The surface quality is therefore increased when used in processing machines.

齿轮 Gearing



锥齿轮 直角型
Bevel gear right angle stage

带有直齿的锥齿轮组的直角箱：使用 1:1 的传动比。这一直角箱技术将较少的结构空间与较高的性能结合在一起。两条轴在一个平面上移动，从而避免了轴向偏差。

A bevel gear set with straight gearing and a 1:1 transmission ratio is used for the angle step. This angle step technology combines a low installation space requirement with high performance capability. The two axes operate on one level, i.e. without an axis offset.



准双曲面齿轮 直角箱
Hypoid gear right angle stage

这一直角型减速机凭借准双曲面齿轮，可以均匀而低振动地运行。这种齿轮类型的另一优势是噪音较低。两条轴相互偏离，也就是位于不同的平面内。

Because of its hypoid teeth, this right angle gearbox operates smoothly and with little vibration. Another advantage of this type of gearing is low noise generation. Both axes are offset to each other, i.e. they are on different levels.

输出法兰 Output flange

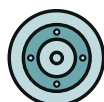

圆形输出法兰
Round type output flange

标准接口，可以简单地装配。机身内不需要螺纹孔或者锁紧螺母。减速机上有螺纹孔，可以用四枚螺钉直接固定。

The standard interface for uncomplicated, easy assembly. A threaded hole in the machine unit or countering with threaded nuts is not required. The gearbox is directly attached to the threaded holes in the gearbox at the application side with four screws.



正方形输出法兰
Square type output flange

通过正方形的输出法兰，可以将减速机直接紧固在机器上，不需要其它的中间法兰。输出法兰带有贯通孔，可以简单而牢固地安装，并且易于接近。

Because of the square output flange, the gearbox can be screwed directly to the machine without an intermediate flange. The output flange with through holes makes simple but secure installation and universal accessibility possible.

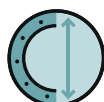

圆形特大号输出法兰
Extra large round type output flange

安装法兰尺寸较大，带有8至12个安装孔，可以传输出最高的转矩。

The large installation flange with 8 or 12 screw-on holes makes the transmission of extremely high torques possible.

轴承 Bearing



低摩擦深沟球轴承
Low-friction deep groove ball bearings

轴承的结构摩擦程度较低，因此减速机能够适应高转速。这种轴承产生的热量低，能够适应长期高转速运作，性能不受影响。

Thanks to the low-friction bearing concept, the gearbox is optimally designed for fast rotation speeds. The low heat development of this bearing makes permanently fast rotation speeds possible without affecting performance.



增强深沟球轴承
Reinforced deep groove ball bearings

特大号的深沟球轴承可以承受较高的径向力与轴向力。驱动元件可以直接安装在输出轴上，不需要额外的支撑组件。

Extra-large deep groove ball bearings make it possible to absorb high levels of radial and axial force. The drive elements can be fitted directly to the output shaft without additional bearing components.



配有预紧的圆锥滚子轴承
Preloaded tapered roller bearings

逐对配有预紧的刚性圆锥滚子可以长久地保障刚性。即使运行方向不断变化，输出轴承也不会出现背隙。

Tapered roller bearings that are pre-stressed in pairs provide additional, permanent rigidity. Even with variable operating directions, the output bearings remain exact.



配有预紧的角接触滚子轴承
Preloaded angular contact roller bearings

逐对摆放的角接触滚子轴承直径较大，可以允许极高的径向力与轴向力。此外，减速机的倾斜力矩得到大幅提高。装有角接触滚子轴承的减速机尤其适合转向台或者齿轮/齿条应用。

Inclined roller bearings arranged in pairs with a large diameter make maximum radial and axial force possible. The tilting moment of the gearbox also increases to a considerable extent. Gearboxes equipped with inclined roller bearings are ideal for rotary tables or rack and pinion applications.

密封件 Seals



径向轴密封
Rotary shaft seal

Neugart 设计的密封件带有预拉紧的径向轴密封，防灰尘，防喷淋水。防护级别达到 IP 65。

The pre-tensioned radial shaft seal designed by Neugart resists dust and jets of water achieving an IP65 protection class.



可选: FFKM 密封件
Option: FFKM seal

针对耐化学腐蚀、耐高温的要求，也可以选用 FFKM 密封件。

An FFKM seal can optionally be used for greater resistance to chemicals and heat.

其它 Others



可选: 降低回程间隙
Option: Reduced backlash

为了达到最高的精度，可以选择 < 1 弧分的同轴减速机；或者选择 < 3 弧分的直角型减速机。

Reduced backlash with < 1 arcmin for coaxial gearboxes, or < 3 arcmin for right angle gearboxes can be optionally selected for maximum accuracy.



可选: 花键输出轴 (DIN 5480)
Option: Splined output shaft (DIN 5480)

您也可以选用符合 DIN 5480 标准的花键输出轴。

A splined output shaft in accordance with DIN 5480 can be optionally used.



可选: 装有小齿轮的高精度减速机
Option: Planetary gearbox with mounted pinion

高精度减速机与斜齿或直齿齿轮组合，可以直接安装在您的齿轮-齿条系统里。

The planetary gearboxes are combined with helical-cut or straight-cut pinions, and can be installed directly into your rack-and-pinion application.



可选: 喷漆表面
Option: Painted surface

减速机可选配喷漆表面。标准颜色为RAL 9005 喷气黑，其他颜色可应要求提供。

Optionally, the gearbox can be selected with a painted surface. The standard color is RAL 9005 jet black, other colors are available on request.



多样的传动比 (i=3 至 i=512 512)
High ratio variety

针对Neugart减速机，可选择的传动比种类尤其多。选择范围从 i=3 到 i=512。

These gearboxes have an extremely wide range of different transmission ratios ranging from i=3 to i=512.



输出端带有超长定心环
Extra long centering collar

超长的定心环，使得输出轴承更符合应用的要求，并改善径向力的支撑，无需增加轴向组装空间。

The long centering collar moves the output bearing closer to the application and thus improves the support of the radial forces without increasing the axial installation space.



法兰输出轴 (按 ISO 9409-1 标准)
Flange output shaft ISO 9409-1

符合 ISO 9409-1 标准的法兰接口确保驱动组件、带盘、直线运行单元或模具库可以简易快速地安装。这种减速机的抗扭刚度比采用一般传动轴的类型高出数倍。整合了定位销孔，在安装时确保牢固可靠。您也可以选择没有定位销孔的型号，而是增加一个螺纹。

The standardized flange interface in accordance with ISO 9409-1 guarantees of quick and easy installation of drive components such as belt pulleys, linear units and turntables. The torsional stiffness of this gearbox is several times greater than those versions with normal output shafts. The integrated dowel pin drill hole provides additional stability during installation. The gearbox is also optionally available without a dowel pin drill hole, but comes with with a different thread instead.



行星齿轮架
Planet carrier in disc design

片状结构的行星齿轮架在一侧支撑行星轮。这种行星齿轮架降低了减速机的转动惯量，从而显著地提高了动态。

The planets are supported at one side in the disk version of the planetary carrier. With this planetary carrier design, the mass inertia of the gearbox is reduced and the dynamics are therefore significantly increased.



行星齿轮架 (笼状结构)
Planet carrier in cage design

笼状结构的行星齿轮架提升了减速机的抗扭刚度，因为行星轮的两侧都得到支撑。减速机的抗扭刚度更高，定位更为精确。可传输的转矩也增加了。

The cage design of the planetary carrier increases the torsional stiffness of the gearbox considerably, since the planets are supported at both sides. The gearbox becomes more torsionally rigid with much more accurate positioning. Greater torque can also be transmitted.



空心轴
Hollow shaft

1级减速机的空心轴可以灵活地穿过电缆。

A hollow shaft with 1-stage gearboxes allows flexible line leadthrough towards the application.



夹紧系统的空心轴，带有胀紧套
Hollow shaft for clamping system with shrink disc

凭借空心轴，可以将带有胀紧套的夹紧系统连接到机床轴。可以从两侧夹紧，并且穿过电线。

A hollow shaft makes it possible to use a clamping system with a shrink disc for force-fitting connection of the machine shaft. Clamping at both sides is possible, and lines can also be led through.



Neugart GmbH

Keltenstraße 16
77971 Kippenheim
Germany
Phone: +49 7825 847-0
Fax: +49 7825 847-2999
Email: sales@neugart.com
Web: www.neugart.com

Neugart USA Corp.

14325 South Lakes Drive
Charlotte, NC 28273
USA
Phone: +1 980 299-9800
Fax: +1 980 299-9799
Email: sales@neugartusa.com
Web: www.neugart.com/en-us

Neugart Planetary Gearboxes (Shenyang) Co., Ltd.

纽卡特行星减速机（沈阳）有限公司
电话：+86 24 2537-4959
传真：+86 24 2537-2552
网址：www.neugart.net.cn
邮箱：sales@neugart.net.cn