



# PSFN

## 负载量最高的精密型减速机 运行十分安静 采用法兰输出轴

我们的 **PSFN** 装有标准法兰接口以及笼状结构的行星齿轮架，因此抗扭刚度极高。专门研发的斜齿把振动降至最低程度。这种高精度行星减速机凭借它的高倾斜力矩，可以满足您的众多要求。

## The precision planetary gearbox for maximum loads with particularly quiet drive and flange output shaft

Thanks to its standardized flange interface and a planet carrier in a cage design, our **PSFN** is extremely torsionally rigid. The specially developed helical gearing reduces vibrations to a minimum. With its high tilting moment, you can demand a lot from this precision planetary gearbox.

额定扭矩  
Nominal output torque **28 - 950 Nm**

径向力  
Radial force **2150 - 23000 N**

轴向力  
Axial force **4300 - 16000 N**

回程间隙  
Torsional backlash **1 - 5 arcmin**

防护等级  
Protection class **IP65**

结构尺寸  
Frame sizes

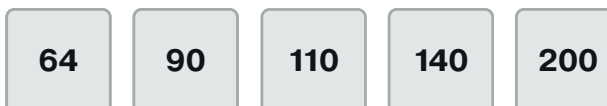

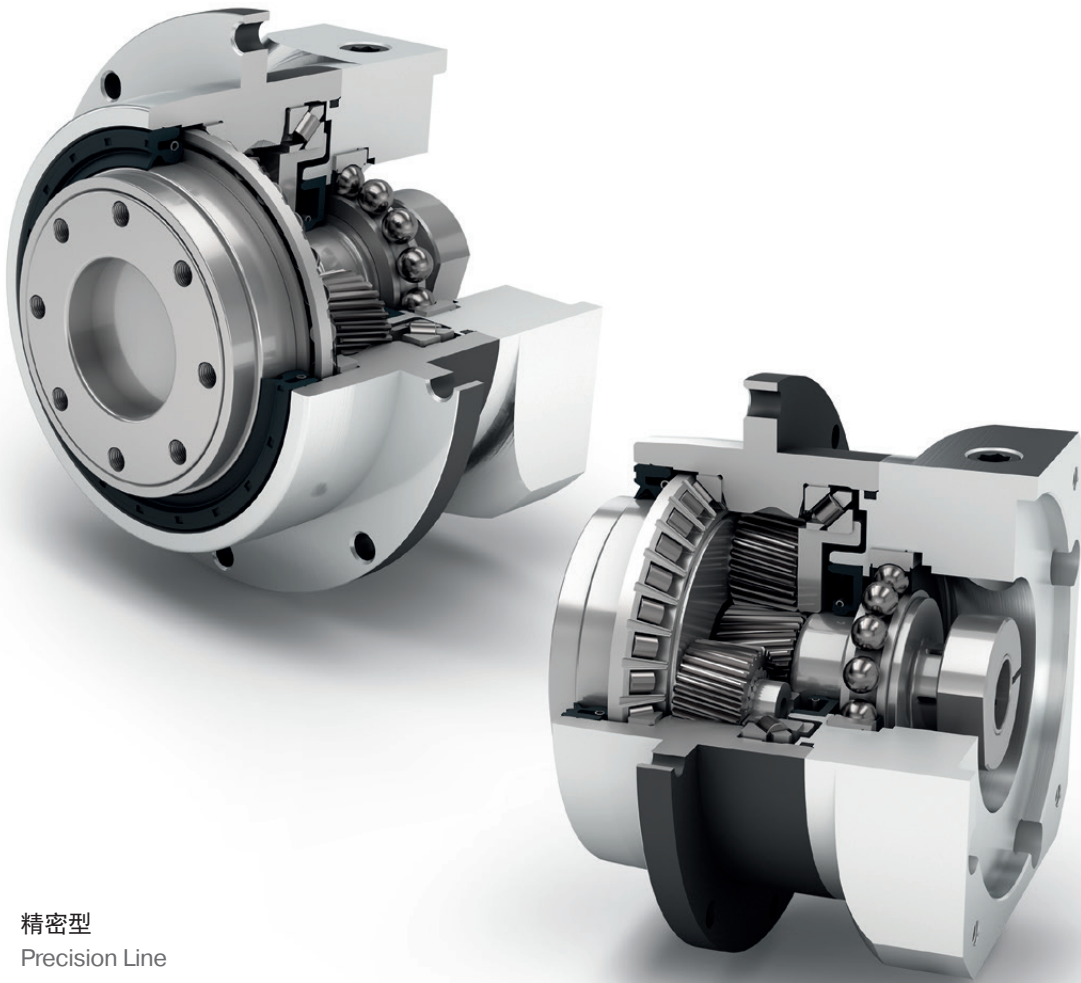

精密型  
Precision Line

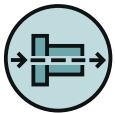

同轴减速机  
Coaxial gearbox



斜齿  
Helical gear



配有预紧的角接触滚子轴承  
Preloaded angular contact roller bearings



法兰输出轴 (按 ISO 9409-1 标准)  
Flange output shaft (ISO 9409-1)



可选: 降低回程间隙  
Option: Reduced backlash



旋转方向 同方向  
Equidirectional rotation

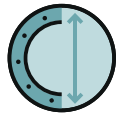

圆形特大号输出法兰  
Extra large round type output flange



径向轴密封  
Rotary shaft seal



行星齿轮架 (笼状结构)  
Planet carrier in cage design



可选: 装有小齿轮的高精度减速机  
132页  
Option: Planetary gearbox with  
mounted pinion on page 132

技术特点的详细解释, 请从第173页读起。  
Detailed explanations of the technical features starting on page 173.

Code	减速机参数	Gearbox characteristics			PSFN064	PSFN090	PSFN110	PSFN140	PSFN200	p <sup>(1)</sup>
	使用寿命 (L <sub>10h</sub> )	Service life (L <sub>10h</sub> )	t <sub>L</sub>	h	20000					
	T <sub>2N</sub> × 0,88 时的使用寿命	Service life at T <sub>2N</sub> × 0,88			30000					
	满载时效率 <sup>(2)</sup>	Efficiency at full load <sup>(2)</sup>	η	%	97					1
					96					2
	最低工作温度	Min. operating temperature	T <sub>min</sub>	°C	-25					
	最高工作温度	Max. operating temperature	T <sub>max</sub>		90					
	防护等级	Protection class	IP65							
S	标准润滑	Standard lubrication	润滑油 (终生润滑) / Oil (lifetime lubrication)							
F	食品级润滑	Food grade lubrication	润滑油 (终生润滑) / Oil (lifetime lubrication)							
L	低温润滑 <sup>(3)</sup>	Low temperature lubrication <sup>(3)</sup>	润滑油 (终生润滑) / Oil (lifetime lubrication)							
	安装位置	Installation position	任意 / Any							
S	标准回程间隙	Standard backlash	j <sub>t</sub>	arcmin	< 3					1
R	降低回程间隙	Reduced backlash			< 5					2
	抗扭刚度 <sup>(2)</sup>	Torsional stiffness <sup>(2)</sup>	C <sub>g</sub>	Nm / arcmin	8,2	21,0	55,0	129,0	374,0	1
					11,8	27,5	62,0	218,0	602,0	
	减速机重量 <sup>(2)</sup>	Gearbox weight <sup>(2)</sup>	m <sub>G</sub>	kg	8,2	21,0	64,0	127,0	365,0	2
					13,3	31,0	81,0	201,0	668,0	
	标准的箱体表面	Standard surface	箱体: 钢 - 热处理后氧化 (黑色) Housing: Steel - heat-treated and post-oxidized (black)							
S			运行噪音 <sup>(4)</sup>	Running noise <sup>(4)</sup>	Q <sub>g</sub>	dB(A)	57		58	63
	基于减速机输入法兰的最大弯矩 <sup>(5)</sup>	Max. bending moment based on the gearbox input flange <sup>(5)</sup>	M <sub>b</sub>	Nm	18	38	80	180	300	1
					18	18	38	80	180	2

输出轴载荷	Output shaft loads			PSFN064	PSFN090	PSFN110	PSFN140	PSFN200	p <sup>(1)</sup>
20,000 h 的径向力 <sup>(6)(7)</sup>	Radial force for 20,000 h <sup>(6)(7)</sup>	F <sub>r20.000h</sub>	N	2150	3950	4900	12000	23000	
20,000 h 的轴向力 <sup>(6)(7)</sup>	Axial force for 20,000 h <sup>(6)(7)</sup>	F <sub>a20.000h</sub>		4300	8200	9500	8500	16000	
30,000 h 的径向力 <sup>(6)(7)</sup>	Radial force for 30,000 h <sup>(6)(7)</sup>	F <sub>r30.000h</sub>		1900	3500	4350	11000	21000	
30,000 h 的轴向力 <sup>(6)(7)</sup>	Axial force for 30,000 h <sup>(6)(7)</sup>	F <sub>a30.000h</sub>		3800	7200	8400	7500	14000	
最大径向力 <sup>(7)(8)</sup>	Maximum radial force <sup>(7)(8)</sup>	F <sub>r Stat</sub>		2150	3950	4900	12000	23000	
最大轴向力 <sup>(7)(8)</sup>	Maximum axial force <sup>(7)(8)</sup>	F <sub>a Stat</sub>		4300	8200	9500	8500	16000	
20,000 h 倾斜力矩 <sup>(6)(8)</sup>	Tilting moment for 20,000 h <sup>(6)(8)</sup>	M <sub>K20.000h</sub>	Nm	132	326	475	1030	2445	
30,000 h 倾斜力矩 <sup>(6)(8)</sup>	Tilting moment for 30,000 h <sup>(6)(8)</sup>	M <sub>K30.000h</sub>		117	289	422	944	2232	

转动惯量	Moment of inertia			PSFN064	PSFN090	PSFN110	PSFN140	PSFN200	p <sup>(1)</sup>
转动惯量 <sup>(2)</sup>	Mass moment of inertia <sup>(2)</sup>	J	kgcm <sup>2</sup>	0,128	0,342	0,892	6,526	22,520	1
				0,188	0,611	1,741	9,670	40,642	
				0,124	0,125	0,325	0,853	6,434	2
				0,180	0,197	0,587	1,836	10,410	

(1) 减速机级数  
 (2) 传动比相关的数值可在 Tec Data Finder 中检索 - www.neugart.com  
 (3) T<sub>min</sub> = -40°C. 理想运行温度最高为 50°C  
 (4) 距离减速机 1 m 时; 在输入转速为 n<sub>1</sub>=3000 min<sup>-1</sup> 且无负荷时测得; i=5  
 (5) 最大电机重量\* (单位: kg) = 0.2 × M<sub>b</sub> / 电机长度 (单位: m)  
 \* 电机重量对称分布  
 \* 水平和固定的安装位置  
 (6) 数据以 n<sub>2</sub>=100 min<sup>-1</sup> 的输出轴转速为准。  
 (7) 以输出轴中心为准  
 (8) 更改 T<sub>2N</sub>, F<sub>r</sub>, F<sub>a</sub> 以及周期和轴承使用寿命时; 数值存在偏差 (部分较高)。利用 NCP 针对应用进行专门设计 - www.neugart.com

(1) Number of stages  
 (2) The ratio-dependent values can be retrieved in Tec Data Finder - www.neugart.com  
 (3) T<sub>min</sub> = -40°C. Optimal operating temperature max. 50°C  
 (4) Sound pressure level from 1 m, measured on input running at n<sub>1</sub>=3000 rpm no load; i=5  
 (5) Max. motor weight\* in kg = 0.2 × M<sub>b</sub> / motor length in m  
 \* with symmetrically distributed motor weight  
 \* with horizontal and stationary mounting  
 (6) These values are based on an output shaft speed of n<sub>2</sub>=100 rpm  
 (7) Based on the end of the output shaft  
 (8) Other (sometimes higher) values following changes to T<sub>2N</sub>, F<sub>r</sub>, F<sub>a</sub>, cycle, and service life of bearing. Application specific configuration with NCP - www.neugart.com

输出扭矩	Output torques			PSFN064	PSFN090	PSFN110	PSFN140	PSFN200	i <sup>(1)</sup>	p <sup>(2)</sup>
额定输出扭矩 <sup>(3)</sup>	Nominal output torque <sup>(3)</sup>	T <sub>2N</sub>	Nm	39	80	180	470	950	4	1
				40	80	175	405	950	5	
				37	78	175	355	900	7	
				39	75	155	350	-	8	
				28	59	140	305	750	10	2
				39	80	180	450	950	16	
				39	80	180	450	950	20	
				40	80	175	405	950	25	
				40	80	175	405	950	35	
				39	80	180	470	950	40	
				40	80	175	405	950	50	
				37	78	175	355	900	70	
				28	59	140	305	750	100	
				最大输出扭矩 <sup>(4)</sup>	Max. output torque <sup>(4)</sup>	T <sub>2max</sub>	Nm	62	128	
64	128	280	648					1520	5	
59	125	280	568					1440	7	
62	120	248	560					-	8	
45	94	224	488					1200	10	
62	128	288	720					1520	16	2
62	128	288	720					1520	20	
64	128	280	648					1520	25	
64	128	280	648					1520	35	
62	128	288	752					1520	40	
64	128	280	648					1520	50	
59	125	280	568					1440	70	
45	94	224	488					1200	100	

<sup>(1)</sup> 传动比 (i=n<sub>1</sub>/n<sub>2</sub>)

<sup>(2)</sup> 减速机级数

<sup>(3)</sup> 利用 NCP 针对应用进行专门设计 – www.neugart.com

<sup>(4)</sup> 允许输出轴转动30.000转; 参见第 166 页

<sup>(1)</sup> Ratios (i=n<sub>1</sub>/n<sub>2</sub>)

<sup>(2)</sup> Number of stages

<sup>(3)</sup> Application specific configuration with NCP – www.neugart.com

<sup>(4)</sup> 30,000 rotations of the output shaft permitted; see page 167

输出扭矩	Output torques			PSFN064	PSFN090	PSFN110	PSFN140	PSFN200	i <sup>(1)</sup>	p <sup>(2)</sup>
急停扭矩 <sup>(3)</sup>	Emergency stop torque <sup>(3)</sup>	T <sub>2Stop</sub>	Nm	120	280	650	1650	3200	4	1
				130	280	650	1650	3200	5	
				80	175	340	1300	3200	7	
				90	200	380	1100	-	8	
				90	200	480	600	1700	10	
				150	300	650	1650	3200	16	
			2	150	300	650	1650	3200	20	
				150	300	650	1650	3200	25	
				150	300	650	1650	3200	35	
				150	300	650	1650	3200	40	
				150	300	650	1650	3200	50	
				80	175	340	1300	3200	70	
				90	200	480	600	1700	100	

输入转速	Input speeds			PSFN064	PSFN090	PSFN110	PSFN140	PSFN200	i <sup>(1)</sup>	p <sup>(2)</sup>
T <sub>2N</sub> 和 S1 时的平均热输入转速 <sup>(4)(5)</sup>	Average thermal input speed at T <sub>2N</sub> and S1 <sup>(4)(5)</sup>	n <sub>1N</sub>	min <sup>-1</sup>	3200 <sup>(6)</sup>	2400 <sup>(6)</sup>	1800 <sup>(6)</sup>	1100 <sup>(6)</sup>	750 <sup>(6)</sup>	4	1
				3800 <sup>(6)</sup>	2950 <sup>(6)</sup>	2250 <sup>(6)</sup>	1350 <sup>(6)</sup>	950 <sup>(6)</sup>	5	
				4500	3800 <sup>(6)</sup>	2950 <sup>(6)</sup>	1800 <sup>(6)</sup>	1250 <sup>(6)</sup>	7	
				4500	4000 <sup>(6)</sup>	3300 <sup>(6)</sup>	1950 <sup>(6)</sup>	-	8	
				4500	4000	3500	2300 <sup>(6)</sup>	1700 <sup>(6)</sup>	10	
				4500	4500	3800 <sup>(6)</sup>	2450 <sup>(6)</sup>	1550 <sup>(6)</sup>	16	
			2	4500	4500	4000	3050 <sup>(6)</sup>	1900 <sup>(6)</sup>	20	
				4500	4500	4000	3350 <sup>(6)</sup>	2050 <sup>(6)</sup>	25	
				4500	4500	4000	3500	2650 <sup>(6)</sup>	35	
				4500	4500	4000	3500	3000 <sup>(6)</sup>	40	
				4500	4500	4000	3500	3000	50	
				4500	4500	4000	3500	3000	70	
				4500	4500	4000	3500	3000	100	
最高机械输入转速 <sup>(4)</sup>	Max. mechanical input speed <sup>(4)</sup>	n <sub>1Limit</sub>	min <sup>-1</sup>	14000	10000	8500	6500	6000		1
				14000	14000	10000	8500	6500		2

<sup>(1)</sup> 传动比 (i=n<sub>1</sub>/n<sub>2</sub>)

<sup>(2)</sup> 减速机级数

<sup>(3)</sup> 允许 1000 次

<sup>(4)</sup> 利用 NCP 针对应用设计转速 – www.neugart.com

<sup>(5)</sup> 定义请参见第 166 页

<sup>(6)</sup> 在 50% T<sub>2N</sub> 输出和 S1 模式下的平均热输入转速

<sup>(1)</sup> Ratios (i=n<sub>1</sub>/n<sub>2</sub>)

<sup>(2)</sup> Number of stages

<sup>(3)</sup> Permitted 1000 times

<sup>(4)</sup> Application-specific speed configurations with NCP – www.neugart.com

<sup>(5)</sup> See page 167 for the definition

<sup>(6)</sup> Average thermal input speed at 50% T<sub>2N</sub> and S1

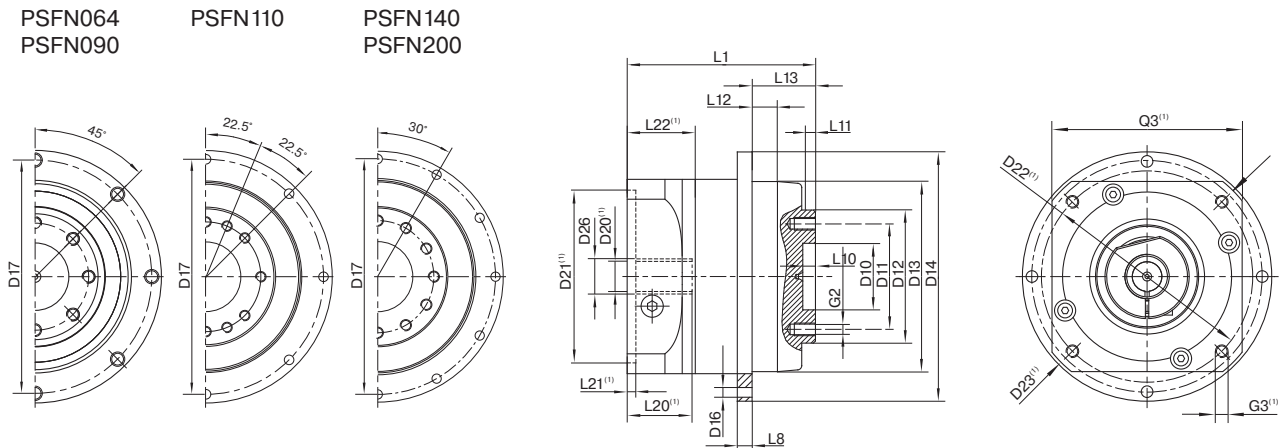

图示为带平键的 PSFN090 / 1 级 / 法兰输出轴 / 14 mm 锁紧系统 / 适配电机法兰 - 2 件式 - 圆形通用法兰 / B5 电机法兰类型  
 Drawing corresponds to a PSFN090 / 1-stage / flange output shaft / 14 mm clamping system / motor adaptation - 2-part - round universal flange / B5 flange type motor

<sup>(1)</sup> 具体尺寸视电机/减速机法兰而定。可以在 [www.neugart.com](http://www.neugart.com) 下 Tec Data Finder 中针对每个电机适配电机特有的输入法兰几何尺寸。  
<sup>(1)</sup> The dimensions vary with the motor/gearbox flange. The input flange dimensions can be retrieved for each specific motor in Tec Data Finder at [www.neugart.com](http://www.neugart.com)

几何尺寸 <sup>(2)</sup>	Geometry <sup>(2)</sup>			PSFN064	PSFN090	PSFN110	PSFN140	PSFN200	p <sup>(3)</sup>	Code
输出端定位凹槽直径	Centering diameter output shaft	D10	H7	20	31,5	40	50	80		
输出端安装孔节圆直径	Pitch circle diameter output shaft	D11		31,5	50	63	80	125		
法兰输出轴的直径	Flange output shaft diameter	D12	h7	40	63	80	100	160		
输出法兰定位凸台直径	Centering diameter output flange	D13		64	90	110	140	200		
输出法兰直径	Flange diameter output	D14		86	118	145	179	247		
输出端安装孔直径	Mounting bore output	D16		4,5 8x45°	5,5 8x45°	5,5 8x45°	6,6 12x30°	9 12x30°		
输出法兰安装孔节圆直径	Pitch circle diameter output flange	D17		79	109	135	168	233		
最小总长	Min. total length	L1		71	89,5	108	142	172	1	
				99,5	111,5	130	173	217	2	
输出端法兰厚度	Flange thickness output	L8		4	7	8	10	12		
输出轴定位凸台深度	Centering depth output shaft	L10		4,5	6,5	6,5	6,5	10		
		L11		3	6	6	6	7		
输出法兰定位凸台深度	Centering depth output flange	L12		10	12	12	14	17,5		
输出法兰长度	Output flange length	L13		19,5	30,0	29,0	38,0	50,0		
电机轴直径 j6/k6	Motor shaft diameter j6/k6	D20		更多信息见第 163/164 页						
输入端锁紧系统直径	Clamping system diameter input	D26		More information on page 163/164						
法兰输出轴 (相似的 ISO 9409-1)	Flange output shaft (similar ISO 9409-1)									D
数量 x 螺纹 x 深度	Number x thread x depth	G2		8 x M5x7	8 x M6x10	12 x M6x12	12 x M8x15	12 x M10x20		
带有配合销孔的法兰输出轴 (ISO 9409-1)	Flange output shaft with dowel hole (ISO 9409-1)									
配合销孔 x 深度	Dowel hole x depth	D15	H7	5x5	6x6	6x6	8x8	10x10		E
数量 x 螺纹 x 深度	Number x thread x depth	G2		7 x M5x7	7 x M6x10	11 x M6x12	11 x M8x15	11 x M10x20		

<sup>(2)</sup> 所有的尺寸单位为mm  
<sup>(3)</sup> 减速机级数

<sup>(2)</sup> Dimensions in mm  
<sup>(3)</sup> Number of stages